

# Research on Construction Project Management: Take Nanchen Community Construction Project in Xingcun Town, Sishui County as an Example

Yichi Jia

*School of Beijing University of Civil Engineering and Architecture, Beijing, China*

**Keywords:** Construction Project Management, Critical Path Method, Construction Efficiency, Project Quality.

**Abstract:** Project management is of great value in practice in many industries. In the construction process of the construction industry, it has a key impact on the entire construction project to effectively analyze the critical path and manage the construction schedule. This paper takes the Nanchen community construction project as an example to study the construction project management, applies critical path method to the project process to find the critical tasks in construction. It is found that almost all construction tasks are critical activities and some problems affecting the progress of project need to be solved. Finally, there are some suggestions given to help to improve the construction efficiency and quality, and finally complete the project within the schedule time and funds.

## 1 INTRODUCTION

Construction project management is the general term for supervision, coordination, and guidance throughout the entire construction process of a construction project. The construction contract is used as the management basis to comprehensively control the resource allocation, cost, schedule arrangement, and construction safety of construction projects. Construction project management of construction projects mainly includes four aspects: construction quality, construction progress, construction safety and project investment, respectively. Construction quality is the basic goal of construction project management; construction progress is its important aspect; construction safety is its essential requirement and project investment is its key indicator (Zhu 2021).

In the past 30 years, China's project management has made great achievements and initially formed a set of systematic management theories and methods. There has been a series of construction-related regulations being formulated. In 2018, the Ministry of Housing and Urban-Rural Development approved the technical standard of construction site supervision information system for construction projects as an industry standard, helping to supervise and manage the quality, safety,

environment, and workers on-site (JGJ/T434-2018). In 2016, the Ministry of Housing and Urban-Rural Development updated the construction quality evaluation standards for construction projects and put forward strict quality evaluation standards for each part of construction projects (GB/T50375-2016). However, due to the influence of traditional management models, many problems exist in project management in China. It is still common to underestimate project quality and delay the project in many projects. Especially in recent years, the more frequent occurrence of major engineering accidents has brought a great threat to the safety of life and property of the country and people. The important reasons for the quality problems of construction projects are inadequate management, imperfect market, unprofessional managers, and imperfect legal system.

So far, many scholars have conducted research and discussion on construction project management methods. Zhu Lei has introduced the concept of construction project management, analyzed the problems in construction project management in the new period, and finally given improvement strategies (Zhu 2021). Both Chen Liangming and Wang Juan have done research on the problems in the site management in construction project management and correspondingly proposed

optimized measures to improve the management level (Chen, Wang 2021)). Wang Xiong has studied the technology application of project management in construction, analyzed the important technologies needed in construction, and given application methods (Wang 2021). While, Yang Yu has proposed an intelligent management method for construction projects, explained the construction and control methods of an intelligent management system in detail, and proposed an innovative application of intelligent management methods to transform old urban communities (Yang 2021). It can be seen that in the above journals, except for the application examples mentioned by Yang Yu in the paper, most of the current researches are comprehensive and theoretical. Still, there is less analysis about real projects.

This paper discusses the construction project management of construction projects with a real project. The organizational structure is as follows: The first part introduces the meaning of construction project management, the research background and current research status. The second part takes the Nanchen Community construction project in Xingcun Town, Sishui County, as an example for construction schedule planning analysis. The third part analyzes the results from the data analysis and gives the suggestions of optimization measures to avoid delaying the construction progress.

## 2 RESEARCH METHODS AND DATA ANALYSIS

This paper adopts scientific research methods in the process of engineering case research, such as case analysis method, quantitative analysis method, comparative analysis method, and literature research method. In addition, this paper also uses the critical path method for data analysis.

### 2.1 General Methods

The case analysis method refers to the method of analyzing a single object in combination with literature data and deriving the general and universal laws of things. This paper analyzes the Nanchen community construction project.

The quantitative analysis method refers to the method of appreciably, systematically and quantitatively describing the obvious content of various documents. This paper quantitatively analyzes and describes the construction progress of the Nanchen community construction project.

Comparative analysis refers to the method of comparing objective things to understand the nature and laws of things and make correct evaluations. This paper compares the planned construction progress and actual construction progress of the Nanchen community construction project.

The literature research method refers to the method of collecting, identifying, and collating literature and forming a scientific understanding of facts through the study of the literature. This paper researches construction project management through the study of industry standards and academic papers.

The ideological line that formed this paper is shown in Figure 1. Because project management is widely applied in the construction industry and the technology is more complex, this paper takes construction project management of construction engineering as the research object, based on an actual engineering case. First, determine the research goal, which is to analyze the factors and reasons that affect the project's construction progress, and give advice. Then, understand the research background through the study of literature and industry standards. Then, analyze the project case information, analyze the problems occurring, analyze the reasons for the problems, and finally give reasonable advice for improvement.

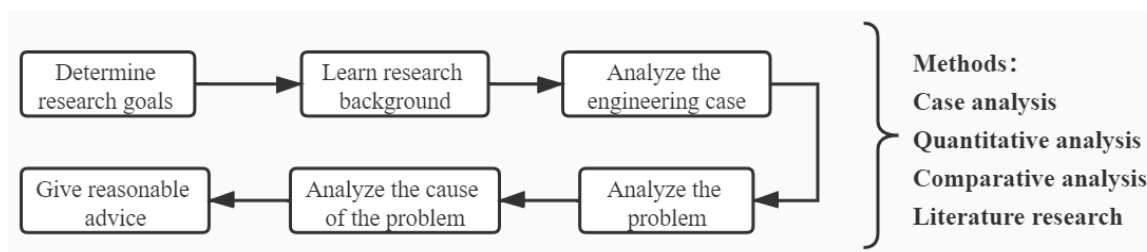

Figure 1: Idea flow chart.

## 2.2 Critical Path Method

### 2.2.1 Definition of Critical Path Method

The critical path refers to the logical path with the longest delay from input to output in the design. Optimizing the critical path is an effective way to increase the speed of design work. Generally, the delay from input to output depends on the path with the longest delay the signal traverses and has nothing to do with other paths with short delays. In the optimisation design process, the critical path method can be used repeatedly until it is impossible to reduce the critical path delay (Zakia and Febrianti 2021).

### 2.2.2 Data Sources

The project discussed in this paper is constructing resettlement buildings for villagers in Nanchen Village, Xingcun Town. The planned total construction area is 49,200 square meters, including 46,200 square meters for residential buildings and garages, 2,000 square meters for commercial

buildings and 1,000 square meters for public buildings. After the completion of the project, it will greatly improve the current living standards and improve the appearance of the village and the living environment of the villagers.

This project is an EPC(Engineering Procurement Construction) project (Qi 2021). The construction enterprise is a member of the EPC project general contracting consortium. The construction enterprise needs to cooperate with the design enterprise to complete the bidding, design, construction and management of the whole process of the project. Due to the large scope and complex content of the whole process management, this paper selects the important part, construction project management, for analysis. The data is obtained from on-site surveys and interviews with managers.

The project will be constructed for 672 days, from January 28, 2021, to November 30, 2022. The schedules for different parts of the construction process are shown in the table below. And the sequence is shown in the figure 2.

Table 1: Construction Time Schedule. (Unit: day).

ID	Activity	Duration	Predecessor
A	Construction Preparation	30	-
B	Pile Foundation Construction	60	A
C	Earth Excavation	40	B
D	Cushion Construction	20	C
D1	Scaffolding	262	D
D2	Hydropower Reserve and Pre-buried	262	D
E	Foundation Construction	35	D
F	Underground Structure Construction	65	E
G	Construction of the Main Structure 1-6 Floors	56	F
G1	Foundation Acceptance	30	F
G2	Backfill Construction	30	G1
H	Construction of the Main Structure 7-13 Floors	56	G
I	Masonry and Secondary Structure Construction	56	G
J	Spring Festival Holiday	30	H, I
K	Masonry Structure Construction	20	J
L	Main Body Maintenance and Acceptance	30	D1,K,G2,D2
L1	Roof Construction	30	L
L2	Installation and Construction of Water, Electricity and Heating	115	L
M	Plastering of Interior Walls	40	L
N	Floor Construction	40	L1, M
N1	Door and Window Installation	110	L1, M
N2	External Wall Insulation	45	L1, M
N3	Exterior Wall Finishing Construction	65	N2
O	Wall and Ceiling Scraping Putty	35	N
P	Ceiling Installation	35	O, L2

<b>P1</b>	Outdoor Water Dispersing and Step Construction	35	O, L2
<b>Q</b>	Roof Surface Construction	20	N1,N3,P,P1
<b>R</b>	Final Cleanup	30	Q
<b>R1</b>	Installation and Debugging	30	Q
<b>S</b>	Completion Acceptance	30	R, R1

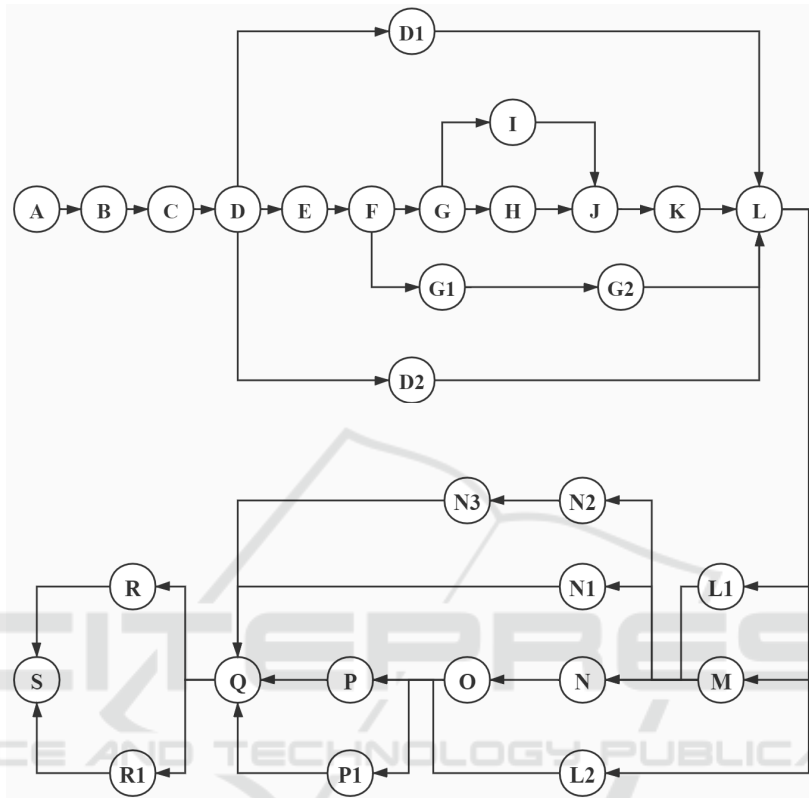

Figure 2: Process flow chart.

**2.2.3 Critical Path Analysis for Schedule**

This paper uses the critical path method to analyze the above data. The formula used in critical path analysis is as follows.

$$EF=ES+Duration \tag{1}$$

Where ES represents the earliest start time, EF represents the earliest finish time. Duration represents the time it takes to finish the task based on experience.

If the activity is a merge activity, the ES of the activity is the longest finish time among all the preceding activities.

$$LS=LF-Duration \tag{2}$$

Where LF represents the latest finish time, LS represents the latest start time.

If the activity is a burst activity, the LF of the activity is the shortest start time among all the subsequent activities.

$$Slack=LF-EF \tag{3}$$

or

$$Slack=LS-ES \tag{4}$$

Where Slack represents the maximum amount of time, a task can be delayed beyond its early start without delaying project completion.

For example, there is no predecessor of A, so the ES of A is 0. The EF equals 0 plus 30 days, which is 30 days. The last task is S, so the LF equals its EF, 672 days. The ES equals 672 days minus 30 days, which is 642 days. The Slack of G1 equals 382 days minus 280 days or 352 days minus 250 days and finally equals 102 days.

The data analysis is shown in the table below.

Table 2: Critical Path Analysis. (Unit: day).

ID	Predecessor	Duration	ES	EF	LS	LF	Slack
A	-	30	0	30	0	30	0
B	A	60	30	90	30	90	0
C	B	40	90	130	90	130	0
D	C	20	130	150	130	150	0
D1	D	262	150	412	150	412	0
D2	D	262	150	412	150	412	0
E	D	35	150	185	150	185	0
F	E	65	185	250	185	250	0
G	F	56	250	306	250	306	0
G1	F	30	250	280	352	382	102
G2	G1	30	280	310	382	412	102
H	G	56	306	362	306	362	0
I	G	56	306	362	306	362	0
J	H, I	30	362	392	362	392	0
K	J	20	392	412	392	412	0
L	D1, K, G2, D2	30	412	442	412	442	0
L1	L	30	442	472	452	482	10
L2	L	115	442	557	442	557	0
M	L	40	442	482	442	482	0
N	L1, M	40	482	522	482	522	0
N1	L1, M	110	482	592	482	592	0
N2	L1, M	45	482	527	482	527	0
N3	N2	65	527	592	527	592	0
O	N	35	522	557	522	557	0
P	O, L2	35	557	592	557	592	0
P1	O, L2	35	557	592	557	592	0
Q	N1, N3, P, P1	20	592	612	592	612	0
R	Q	30	612	642	612	642	0
R1	Q	30	612	642	612	642	0
S	R, R1	30	642	672	642	672	0

### 3 RESULTS AND SOLUTIONS

#### 3.1 Results of Data Analysis

According to the analysis results, the Slack of most construction tasks is 0. The Slack is 0 means the construction task is a critical activity. The paths excluding foundation acceptance(G1), backfill construction(G2), and roof construction(L1) are all critical paths during the entire construction process. And the construction tasks except for these three tasks are critical parts of the construction process, which means they can not be delayed. However, in view of the importance of foundation acceptance and backfill construction, these two tasks are normally not postponed. Therefore, it can be seen that the

construction process is tightly arranged, and more efficient construction project management is also required to ensure that the project is carried out in high efficiency and high quality as planned. And the problems affect the progress should be found and solved in time.

#### 3.2 Problem Analysis in Construction

Some problems are happening during the construction of this project, which have a certain impact on the progress and quality of the project. Among the parts that have been completed currently, the progress of the construction of 1-6 floors of the main body was greatly affected by the problems. The following will describe the problems in detail.

### 3.2.1 Shortage of Staff

It is still under the condition of the COVID-19 epidemic during the construction period, so the progress of the project is affected by the epidemic to a certain extent. The range of optional labor subcontracting teams has been reduced, and most of which are local teams, resulting in a reduction in available workers. And their practical ability them cannot be guaranteed. There are few on-site workers, and some workers have the poor practical ability, resulting in a lag in construction progress.

### 3.2.2 Lack of Communication between Design Enterprise and Construction Enterprise

The design enterprise and construction enterprise of this project are not in the same city. Affected by the epidemic, there are not enough staff of design enterprise in the construction site. When the design enterprise is needed, it is easy to be absent, which leads to the lack of communication between the design enterprise and the construction enterprise. Sometimes the staff of the design enterprise at the construction site cannot completely solve the problem, so they need to connect the design enterprise online to get the solution. Low communication efficiency affects project progress.

### 3.2.3 Difference between the Design and the Reality

Due to the lack of a sufficient investigation of the building materials market, the design enterprise changes some materials and related techniques, and the construction difficulty and cost are increased.

The original design drawings plan to use non-clay sintered bricks with strength MU20 in the bottom frame structure of the multi-storey building. But during the construction process, there are not these types of bricks produced in local and nearby cities. Then the construction enterprise communicates with the design enterprise, after the owner's consent, finally changes the strength from MU20 to MU15, and at the same time increases the size of the upper structural column and the number of steel bars at the corresponding position of the bottom frame column.

### 3.2.4 The Safety Awareness and Technology of Staff Need to Be Improved

Some on-site workers have irregular construction operations, and they misunderstand regulations and

safety signs. The failure to observe labor discipline and safety regulations during construction operations would endanger the personal safety of workers. In addition, some workers are not professional enough, and there is a phenomenon of focusing on the progress and neglecting data at the construction site.

### 3.2.5 Quality Defects

Affected by the poor local woodworking technology and other factors, some units had mold expansion and slurry running during concrete pouring. Honeycomb pitted surface, and rotten roots appeared after concrete pouring, and then they were repaired. Due to insufficient vibration, a honeycomb pitted surface appeared in some parts. Because the bottom is not cleaning thoroughly before pouring concrete at the junction of the two parts of the stairs, the bad connection and slag inclusions are caused. These quality defects do not have much impact on the building's bearing capacity, but it is still necessary to avoid them during the construction process.

### 3.2.6 Mediation of Local Relations

Because this project is the resettlement house for villagers in Nanchen Village, the original houses need to be demolished. The demolition matters and demolition compensation need to be communicated with the villagers. Therefore, it takes some time to negotiate, which affected the previous demolition work and delayed the total duration.

## 3.3 Reasonable Solution

These problems have affected the construction progress of the project, and also the quality of the project to a certain extent. Therefore, it is necessary to strengthen all aspects of management to ensure that the project is carried out on schedule with expected quality.

### 3.3.1 Strengthen Communication among All Enterprises

The construction enterprise should strengthen communication with the design enterprise. When preparing detailed constructional drawings, construction technicians should communicate with the design enterprise to ensure that the nodes are accurate and the drawings are feasible. Technicians should check the finished drawings comprehensively at the drawing review and confession stage, striving to find problems in time and handle them properly.



The communication among the construction enterprise, the supervision enterprise, and the design enterprise should be strengthened to ensure that the project construction and coordinating the external environment. The materials and machines should be checked and accepted timely when entering the construction site to avoid missing anything.

### 3.3.2 Construction Material Management

Construction enterprises should adopt effective material management methods to avoid material problems that will affect the construction progress.

They should conduct research in advance on the building materials market where the project is located to ensure that the building materials actually purchased are the same as the materials in design. The procurement link is the first link of material management. Before purchasing materials, construction enterprises must learn the supply capacity and reputation of suppliers. At the same time, construction enterprises must thoroughly check the material specifications and qualification certificates to not affect the construction progress due to the difference between the actual and required specifications.

When storing materials, workers must follow the material storage specifications. In addition, managers should timely sample the incoming materials and submit them for inspection according to the criterion. During the use of the materials, managers should check the materials again, laying the foundation for improving the quality of the construction project.

### 3.3.3 Construction Safety Management

It makes sense to improve the quality of construction only while ensuring the safety of workers. Therefore, the construction enterprise should improve safety education for workers so that everyone can raise safety awareness and correctly understand the terms and signs of the construction management system.

Besides the workers, the managers should also raise their safety awareness. Firstly, they should improve their ability to manage, organize and coordinate everything. Also, they should do the security check on every construction procedure workers do in a timely manner. Once there is a safety hazard, it must be eliminated in time. Thirdly, managers should check the situation of personnel protective equipment worn by the workers on the construction site. If some workers do not wear

personnel protective equipment at the construction site, managers should remind them in time.

### 3.3.4 Construction Quality Management

To shift the post-inspection of project quality to pre-control and achieve the goal of "prevention first", it is necessary to strengthen the quality control of the construction process.

To make the early quality control more effectively, first, workers must strictly follow the process. The process is the basis for construction operations and the prerequisite to ensure quality. Workers should be trained in advance and supervised to strictly complete each process. Second, the quality of conditions that affect the process, including the operators, materials, machines, methods and environment, also needs to be controlled. And finally, on-site managers should timely proofread the drawings, check the construction quality and improve workers' awareness of construction according to drawings. They should count and analyse the quality data in time, eliminate weaknesses of the project quality, and finally reduce the phenomenon of focusing on progress and neglecting data (Chen 2021).

## 4 CONCLUSIONS

This paper studies the application of project management in the construction industry.

This paper applies the critical path method to the construction management, analyzes the construction schedule of the Nanchen community project, and finally gets the following conclusions.

(1) Almost all construction tasks are critical activities in the critical paths which means there is little time for this project to delay, so the problems affecting the progress should be paid more attention to.

(2) There are some problems that affect the construction schedule, such as the quality defects, shortage of staff and poor communication in the construction process.

(3) Nanchen community project should strengthen the communication and improve material, safety and quality management to ensure that problems can be solved and project continues successfully.

It is expected that the Nanchen community project could improve the construction condition and efficiency through the research in this paper.

At present, there have been many studies on the progress, cost and resource optimization of the project at the early stage, but there are still many problems about construction period and quality in the actual construction process. The actual construction situation is not exactly same as the theoretical analysis. It is hopeful that there will be more researches on reasons and solutions for the differences between actual situation and theoretical analysis, and also how to control cost and avoid these problems during the construction process, which can quote typical cases for illustration.

## REFERENCES

- Chen Liangming. (2021). Construction Site Management and Optimization Measures in Construction Project Management. *Intelligent City*, 2021(14):74~75.
- Chen Xuekuan. (2021). Research on the Content of Civil Engineering Project Management and Its Optimization Measures. *Management Exploration*, 2021(09):25~27.
- GB/T50375-2016, Construction Quality Evaluation Standard of Building Engineering.
- JGJ/T434-2018, Technical Standards for Construction Site Supervision Information System of Building Engineering.
- Qi Qiang. (2021). Research on the optimization of construction project management under EPC General contracting Mode. *Residence*, 2021(24):121~122.
- Wang Juan. (2021). Construction Site Management and Optimization Measures in Construction Project Management. *Management*, 2021(7):12~13.
- Wang Xiong. (2021). Research on the Application of Project Management Technology in Civil Engineering Construction. *Engineering Construction Standardization*, 2021(14):114~116.
- Yang Yu. (2021). Research on the Application and Practice of the Intelligent Management Mode of Construction Projects. *Real Estate World*, 2021(14):107~111.
- Zakia and Dian Febrianti. (2021). The Critical Path Method in Construction Project Rescheduling. *IOP Conference Series: Earth and Environmental Science*, 2021, 832
- Zhu Lei. (2021). Construction Project Management. *Green Building Materials*, 2021(7):143~144.