

Analysis of Tripadvisor Acceptance in Indonesia using Technology Acceptance Model 2: Case Study of E-Ticketing in Solid Travel Consumers

Rizki Annisa Putri¹, Dwi Kartikasari²

¹Applied Business Administration, Politeknik Negeri Batam

²Department Business Management, Batam, Indonesia

Jl. Ahmad Yani, Batam Centre 29461, Indonesia

Keywords: Solid Travel, E-Ticketing, TripAdvisor, Technology Acceptance Model 2

Abstract: This study is aimed to determine the Acceptance of E-Ticketing on TripAdvisor in Solid Travel Batam. The respondents of this research were Solid Travel consumers who have made transactions using the e-ticketing system on TripAdvisor. The sample size for this study was 260 respondents. The sampling technique using the purposive sampling method with the Slovin formula. In this research, data were collected through questionnaires given to respondents through the google form link. This research used the descriptive method. This method is done by using the Validity Test, Reliability Test, Linearity Test, and SEM (Structural Equation Model) Test. The results of this study are all variables in the TAM 2 (Technology Acceptance Model 2) model correlate with each other.

1 INTRODUCTION

1.1 Background

In this digital era, the internet has become such a necessity for everyday life. It has also led to many great advancements for modern businesses, including travel businesses. The use of the internet and technology make things much easier.

The competition in the travel industry is not only about the products, but also the services offered to the consumer. One of the most impactful ones is e-Ticketing service. E-Ticketing allows the consumer to do everything online, whether it's on a website or a mobile APP. The consumer can book a ticket anytime, anywhere. Since everything is done online (online booking), the consumer will get an electronic ticket (e-Ticket) instead of a paper ticket. An e-Ticket is a record of a booking which contains all the same information that a paper ticket has on it. But instead of being physically printed, it's stored in the computer system. It is basically the equivalent of the old style paper ticket, except with e-Tickets, the consumers no longer have to worry about losing their ticket.

One of the companies in the travel industry that offers e-Ticketing service is Solid Travel. This

company is located in Batam and provides travel and tourism-related services packages in the city and ferry tickets for Singapore to/from Batam. Since not all of its consumers is from Batam City, even those who are from the city sometimes just don't have time to come to the office to make a booking. So the e-Ticketing service really helps the consumer to make things easier. Solid Travel is also quite active in promoting its products and services on TripAdvisor so more consumers make bookings there. For that reason, the author wants to make an analysis of consumer acceptance of the e-Ticketing system on TripAdvisor.

Unfortunately, up to this point not every consumer is lucky enough to have access or knows how to take full advantage of the internet, including the e-Ticketing system. According to the research, there are also some risks of using eTicket that might get the consumer some trouble, such as internet connection problems, data loss, run out of phone's battery, etc. In order to achieve the objectives of implementing e-ticketing, an evaluation is needed to assess the acceptance of the e-ticketing system. Add to this the use of E-Ticketing that is not yet in great demand by customers due to the unstable level of user visits (Alhabsyi et al., 2018).

Therefore the researcher raised the title "ANALYSIS OF TRIPADVISOR ACCEPTANCE IN INDONESIA USING TECHNOLOGY ACCEPTANCE MODEL 2: CASE STUDY OF E-TICKETING IN SOLID TRAVEL CONSUMERS"

1.2 Problem Formulation

The formulation of the problem that can be found in the background above is as follows:

1. Does subjective norms have a significant effect to user image of the E-Ticketing system on TripAdvisor?
 2. Does image have a significant effect to user perceived usefulness of the E-Ticketing system on TripAdvisor?
 3. Does job relevance have a significant effect to user perceived usefulness of the E-Ticketing system on TripAdvisor?
 4. Does output quality have a significant effect to user perceived usefulness of the E-Ticketing system on TripAdvisor?
 5. Does result demonstrability have a significant effect to user perceived usefulness of the E-Ticketing system on TripAdvisor?
 6. Does subjective norms moderated by experience have a significant effect to user perceived usefulness of the E-Ticketing system on TripAdvisor?
 7. Does subjective norms moderated by experience have a significant effect to user intention to use of the E-Ticketing system on TripAdvisor?
 8. Does subjective norms moderated by voluntariness have a significant effect to user intention to use of the E-Ticketing system on TripAdvisor?
 9. Does perceived ease of use have a significant effect to user perceived usefulness of the E-Ticketing system on TripAdvisor?
 10. Does the perceived usefulness have a significant effect to user intention to use of the E-Ticketing system on TripAdvisor?
 11. Does perceived ease of use have a significant effect to user intention to use of the E-Ticketing system on TripAdvisor?
 12. Does intention to use have a significant effect to user usage behavior of the E-Ticketing system on TripAdvisor?
1. To be able to know the significant effect of subjective norm with user image of the E-Ticketing system on TripAdvisor.
 2. To be able to know the significant effect of image with user perceived usefulness of the E-Ticketing system on TripAdvisor.
 3. To be able to know the significant effect of job relevance with user perceived usefulness of the E-Ticketing system on TripAdvisor.
 4. To be able to know the significant effect of output quality with user perceived usefulness of the E-Ticketing system on TripAdvisor.
 5. To be able to know the significant effect of result demonstrability with user perceived usefulness of the E-Ticketing system on TripAdvisor.
 6. To be able to know the significant effect of subjective norms moderated by experience with user perceived usefulness of the E-Ticketing system on TripAdvisor.
 7. To be able to know the significant effect of subjective norms moderated by experience with user intention to use of the E-Ticketing system on TripAdvisor?
 8. To be able to know the significant effect of subjective norms moderated by voluntariness with user intention to use of the E-Ticketing system on TripAdvisor.
 9. To be able to know the significant effect of perceived ease of use with user perceived usefulness of the E-Ticketing system on TripAdvisor.
 10. To be able to know the significant effect of perceived usefulness with user intention to use of the E-Ticketing system on TripAdvisor?
 11. To be able to know the significant effect of perceived ease of use with user intention to use of the E-Ticketing system on TripAdvisor?
 12. To be able to know the significant effect of intention to use with user behavior of the E-Ticketing system on TripAdvisor?

1.4 Benefit of Research

Based on the above research, as a result that can be implemented as well as beneficial for the parties concerned in it, the following research benefits can be implemented as follows:

- a. Practical benefits,
The practical benefits is to provide advice to relevant institutions and to improve the management strategy of the E-Ticketing system at Solid Travel.

1.3 Research Purpose

The research purpose to be achieved are as follows:

b. Theoretical Benefits,

The theoretical benefits is expected to find out the interests and behavior of customers when using the e-ticketing system on TripAdvisor on Solid Travel and being an input related to existing learning system about user acceptance of technology, especially on the e-ticketing system in Indonesia and also the results of this study is expected to provide recommendations to organizations with the aim of developing the use of e-tickets and providing guidance or input for researchers of similar objects.

2 REVIEW OF LITERATURE

2.1 Theoretical Review

1. TripAdvisor

TripAdvisor is an online travel company that operates a website and mobile app with user-generated content, a comparison shopping website, and offers online hotel reservations as well as bookings for transportation, lodging, travel experiences, and restaurants.

2. E-Ticketing

E-ticketing is an electronic ticket or the digital ticket equivalent of a paper ticket. The term is most commonly associated with airline issued tickets.

3. Technology Acceptance Model 2

TAM 2 is a theory of acceptance of information technology systems designed to explain how users use and understand an information technology system. The original TAM construct made is perceived usefulness, perceived ease of use, and user intention to use and then they added some external constructs experience and voluntariness (Venkatesh & Davis, 2000).

2.2 Research Accomplished

1. Research from M. I. Alhabsyi (2017) under the title *Analisis Penerimaan Website E- Ticketing Menggunakan TAM 2 Pada Perusahaan KAHA Tours & Travel* and the result in research is Perceived of Use affects User Intervention.
2. Research from Sri Endarwati, Ningsih, & Utami (2011) under the title *Analisis Penerimaan Pengguna E-Ticketing Dengan Pendekatan Technology Acceptance Model (TAM) pada Perusahaan Penerbangan di Wilayah Yogyakarta* and the result in research is e-ticketing users are still very low.

3. Research from Dyna S (2011) under the title *Technology Acceptance Model of Mobile Ticketing* and the result in is prior experience, perceived usefulness, trust, has a positive effects on the intention to use.

2.3 Conceptual Framework

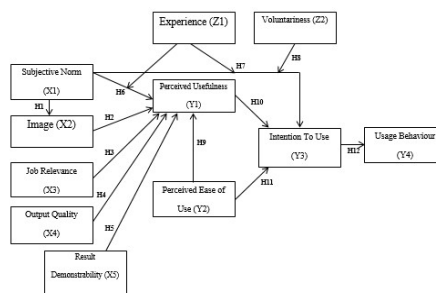

Figure 1 Conceptual Model Technology Acceptance Model 2

- Hypothesis 1 = Subjective norm expected has a significant effect on user image of the E-Ticketing system on TripAdvisor.
- Hypothesis 2 = Image expected has a significant effect on user perceived usefulness of the E-Ticketing system on TripAdvisor.
- Hypothesis 3 = Job relevance expected has a significant effect on user perceived usefulness of the E-Ticketing system on TripAdvisor.
- Hypothesis 4 = Output quality expected has a significant effect on user perceived usefulness of the E-Ticketing system on TripAdvisor.
- Hypothesis 5 = Result demonstrability expected has a significant effect on user perceived usefulness of the E-Ticketing system on TripAdvisor.
- Hypothesis 6 = Subjective norm moderated with experience expected has a significant effect on user perceived usefulness of the E-Ticketing system on TripAdvisor.
- Hypothesis 7 = Subjective norm moderated with experience expected has a significant effect on user intention of use of the E-Ticketing system on TripAdvisor.
- Hypothesis 8 = subjective norm moderated with voluntariness expected has a significant effect on user intention to use of the E-Ticketing system on TripAdvisor.
- Hypothesis 9 = Perceived ease of use expected has a significant effect on user intention to use of the E-Ticketing system on TripAdvisor.

- Hypothesis 10 = Perceived usefulness expected has a significant effect on the intention of users of the E- Ticketing system.
- Hypothesis 11 = Perceived ease of use of information systems has a positive effect on user intention to use of the E-Ticketing system on TripAdvisor.
- Hypothesis 12 = Intention to use has a positive effect on user usage behavior of the E-Ticketing system on TripAdvisor.

3 METHOD OF RESEARCH

3.1 Research Design

This thesis will use quantitative research. This research is quantitative because the data from this study are in the form of numbers and the analysis will be conducted using a statistical program (Sugiyono, 2013).

3.2 Research Focus and Subjects

The focus of researchers in this study is the customer of Solid Travel. The subjects of this research are the customer of Solid Travel who have made transactions using the e-ticketing system on TripAdvisor.

3.3 Data Collection Techniques

This study uses data collection techniques in questionnaire. The questionnaire created with a list of structured questions with multiple choice questions. This questionnaire will be the source of data that can be used for data analysis material. The answer to each question will be measured on a Likert scale, which is a scale that has gradations from very positive to negative (Likert, 1932). The survey will be conducted online and will be uploaded at <https://docs.google.com/forms> so that the data collected can be structured.

4 RESULT AND DISCUSSION

4.1 Result

In this chapter the researcher will describe the data and the results of research on the problems that have been formulated in Chapter I.

4.4.1 Validity Test

Validity test is used to calculate the correlation value of each question item with the total score using SPSS. The question items will show significant results at values less than 0.01. In this study $N = 260$, then $df = N (260) - 2 = 258$. $df 258 = 0.159$. Decision making is measured if r Calculate (Corrected Item-Total Correlation) is higher than r Table that is equal to 0.159. Basic decision making, r Calculate $> r$ Table then the variable is said to be valid r Calculate $< r$ Table then the variable is invalid.

Table 1: Validity Test

Variable	r Calculate	r Table	Validation
Subjective Norm			
X1.1	0,665	0,159	Valid
X1.2	0,792	0,159	Valid
Image			
X2.1	0,811	0,159	Valid
X2.2	0,780	0,159	Valid
X2.3	0,606	0,159	Valid
Job Relevance			
X3.1	0,811	0,159	Valid
X3.2	0,748	0,159	Valid
Output Quality			
X4.1	0,781	0,159	Valid
X4.2	0,791	0,159	Valid
Result Demonstrability			
X5.1	0,849	0,159	Valid
X5.2	0,758	0,159	Valid
X5.3	0,802	0,159	Valid
Perceived Usefulness			
Y1.1	0,800	0,159	Valid
Y1.2	0,807	0,159	Valid
Y1.3	0,844	0,159	Valid
Perceived Ease Of Use			
Y2.1	0,833	0,159	Valid
Y2.2	0,825	0,159	Valid
Y2.3	0,860	0,159	Valid

Intention To Use			
Y3.1	0,873	0,159	Valid
Y3.2	0,886	0,159	Valid
Usage Behavior			
Y4.1	0,789	0,159	Valid
Y4.2	0,802	0,159	Valid
Experience			
Z1.1	0,762	0,159	Valid
Z1.2	0,825	0,159	Valid
Voluntariness			
Z2.1	0,804	0,159	Valid
Z2.2	0,669	0,159	Valid

4.4.2 Reliability Test

Measurements in the reliability test of this study were done by measuring once by combining all the variables to be tested for reliability by using SPSS version 16. The test results were declared reliability if Cronbach's Alpha statistical reliability values > 0,60.

Table 2: Reliability Test

Total Value Test	Cronbach's Alpha	Result
0,974	0,6	Reliable

4.4.3 Linearity Test

Linearity test is used to determine whether two variables have a significant linear relationship or not. Linearity testing by way of linear regression using SPSS and variable advance has passed the test of validity and reliability. It is stated that it passed the linearity test if the value of Significant Linearity is <0,05.

Table 3: Linearity Test

Variable Name	Significant Linearity	Expected Value	Result
X1 → X2	0,000	<0,05	Linier
X2 → Y1	0,000	<0,05	Linier
X3 → Y1	0,000	<0,05	Linier
X4 → Y1	0,000	<0,05	Linier

X5 → Y1	0,000	<0,05	Linier
Z1 → Y1	0,000	<0,05	Linier
Z1 → Y3	0,000	<0,05	Linier
Z2 → Y3	0,000	<0,05	Linier
Y2 → Y1	0,000	<0,05	Linier
Y1 → Y3	0,000	<0,05	Linier
Y2 → Y3	0,000	<0,05	Linier
Y3 → Y4	0,000	<0,05	Linier

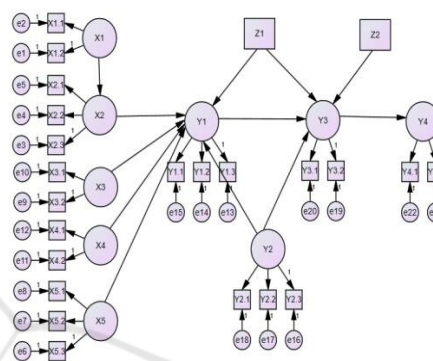

Figure 2 Results of Dependent Variable and Independent Variable Relationships

4.4.4 SEM Analysis

After conducting the validity test, the reliability test and the linearity test and the test results are valid with the test standards used. Data has been normal multivariate and also passed the Outlier test so that testing can proceed to the SEM test phase using AMOS.

From the figure below it can be seen the results of the TAM 2 model processing into AMOS to test the correlation of independent variables to the dependent variable

Table 4 Goodness of Fit

Index Goodness of Fit	Result	Expected value	Information
Chi-Square	2882,199	Expected to be small	good
Probabilities	0,000	≥0,05	not good
CMIN/DF	11,707	≤2	not good
RMSEA	0,203	≤0,08	not good
P Ratio	0,891	≥0,60	good
CFI	0,970	≥0,95	good
GFI	0,441	≥0,95	not good

If there are two Goodness of Fit criteria that meet the criteria, the model is said to be good or feasible (Solimun, 2006). In the table above, the Fit Model Testing Result looks at the value of Chi- square, Significance Probability, CMIN / DF, RMSEA, P Ratio, CFI, GFI. declared eligible for the next process.

From the appropriate model, each path can be determined from each variable. The path coefficient is the hypothesis in this study. The Independent Variable with the symbol (X), which is presented in the following structural equation:

- X1 = Subjective Norm
- X2 = Image
- X3 = Job Relevance
- X4 = Output Quality
- X5 = Result Demonstrability

The dependent variable with the symbol (Y), as follows:

- Y1 = Perceived Usefulness
- Y2 = Perceived Ease of Use
- Y3 = Intention to Use
- Y4 = Usage Behavior

The moderator variable with the symbol (Z), as follows:

- Z1 = Experience
- Z2 = voluntariness

4.4.5 Hypothesis Test

After the goodness of fit test and the model are considered feasible, the next step is to test the hypothesis which is the goal of this study by using the SEM method by looking at the probability or p-value of the structural relationship. The research hypothesis was tested using SPSS AMOS, The hypothesis was accepted or considered significant if the p-value was less than 0.05 ($\alpha = 5\%$).

Table 5 Hypothesis Test

	S.E.	C.R.	P	Result
X2<-X1	0,102	9,322	***	significant
Y1<-X2	0,027	-2,707	0,007	significant
Y1<-X3	0,043	-7,75	***	significant
Y1<-X4	0,028	12,381	***	significant
Y1<-X5	0,033	10,656	***	significant
Y1<-Z1	0,01	4,082	***	significant
Y3<-Z1	0,012	9,555	***	significant
Y3<-Z2	0,012	6,208	***	significant
Y1<-Y2	0,033	15,274	***	significant
Y3<-Y1	0,061	-7,551	***	significant
Y3<-Y2	0,056	18,609	***	significant
Y4<-Y3	0,073	15,703	***	significant

Based on the table above, the results of the hypothesis test have outlined how much a significant influence on each variable examined in this study. From these data the following Hypothesis test results have significant results:

1. Subjective Norm (X1) have significant effect to Image (X2). The results seen from the p-value (***) shows a very small number far below 0,05.
2. Image (X2) have significant effect to perceived usefulness (Y1). The results seen from the p-value of 0,007 is smaller than 0.05.
3. Job Relevance (X3) have significant effect to perceived usefulness (Y1). The results seen from the p-value (***) shows a very small number far below 0,05.
4. Quality Output (X4) have significant effect to perceived usefulness (Y1). The results seen from the p-value (***) shows a very small number far below 0,05.
5. Results Demonstrability (X5) have significant effect to perceived usefulness (Y1). The results seen from the p-value (***) shows a very small number far below 0,05.
6. Subjective Norm that moderated by Experience (Z1) have a significant effect on perceived usefulness (Y1). The results seen from the p-value (***) shows a very small number far below 0,05 .
7. Subjective Norms moderated by Experience (Z1) have a significant effect on Intention to Use (Y3). The results seen from the p-value (***) shows a very small number far below 0,05.
8. Subjective Norm moderated by Voluntariness (Z2) have a significant effect on Intention to Use (Y3). The results seen from the p-value (***) shows a very small number far below 0,05.
9. Perceived usefulness (Y1) have significant effect to perceived ease of use (Y2). The results seen from the p-value (***) shows a very small number far below 0,05.
10. Perceived usefulness (Y1) have significant effect to Intention to Use (Y3). The results seen from the p-value (***) shows a very small number far below 0,05.
11. Perceived Ease of Use (Y2) have significant effect to Intention to Use (Y3). The results seen from the p-value (***) shows a very small number far below 0,05.
12. Intention to Use (Y3) have significant effect to Usage Behavior (Y4) The results seen from the

p-value (***) show a very small number far below 0,05.

4.2 Discussion

The discussion based on statistical analysis and hypothesis testing that has been done on each research variable:

1 Subjective Norm to Image

Based on the test results in the first hypothesis, it was found that subjective norm had a significant effect to the image on E-Ticketing system users on TripAdvisor at Solid Travel. Subjective Norm can be said to have a significant effect on the Image because it has a p value smaller than 0.05.

2 Image to Perceived Usefulness

Based on the test results in the first hypothesis, it was found that image had a significant effect to perceived usefulness on E-Ticketing system users on TripAdvisor at Solid Travel. Image can be said to have a significant effect on perceived usefulness because it has a p value smaller than 0.05.

3 Job Relevance to Perceived Usefulness

Based on the test results in the first hypothesis, it was found that job relevance had a significant effect to perceived usefulness on E-Ticketing system users on TripAdvisor at Solid Travel. Job relevance can be said to have a significant effect on perceived usefulness because it has a p value smaller than 0.05.

4 Quality Output to Perceived Usefulness

Based on the test results in the first hypothesis, it was found that quality output had a significant effect to perceived usefulness on E-Ticketing system users on TripAdvisor at Solid Travel. Quality output can be said to have a significant effect on perceived usefulness because it has a p value smaller than 0.05.

5 Results Demonstrability to Perceived Usefulness

Based on the test results in the first hypothesis, it was found that results demonstrability had a significant effect to perceived usefulness on E-Ticketing system users on TripAdvisor at Solid Travel. Results demonstrability can be said to have a significant effect on perceived usefulness because it has a p value smaller than 0.05.

6 Subjective Norm moderated by Experience to Perceived Usefulness

Based on the test results in the first hypothesis, it was found that subjective norm moderated by experience

had a significant effect to perceived usefulness on E-Ticketing system users on TripAdvisor at Solid Travel. Subjective norm by experience can be said to have a significant effect on perceived usefulness because it has a p value smaller than 0.05.

7 Subjective Norm moderated by Experience to Intention to Use

Based on the test results in the first hypothesis, it was found that subjective norm moderated by experience had a significant effect to intention to use on E-Ticketing system users on TripAdvisor at Solid Travel. Subjective norm by experience can be said to have a significant effect on perceived usefulness because it has a p value smaller than 0.05.

8 Subjective Norm moderated by Voluntariness to Intention to Use

Based on the test results in the first hypothesis, it was found that subjective norm moderated by voluntariness had a significant effect to intention to use on E-Ticketing system users on TripAdvisor at Solid Travel. Subjective norm by voluntariness can be said to have a significant effect on perceived usefulness because it has a p value smaller than 0.05.

9 Perceived Usefulness to Perceived Ease of Use

Based on the test results in the first hypothesis, it was found that perceived usefulness had a significant effect to perceived ease of use on E-Ticketing system users on TripAdvisor at Solid Travel. Perceived usefulness can be said to have a significant effect on perceived usefulness because it has a p value smaller than 0.05.

10 Perceived Usefulness to Intention to Use

Based on the test results in the first hypothesis, it was found that perceived usefulness had a significant effect to intention to use on E-Ticketing system users on TripAdvisor at Solid Travel. Perceived usefulness by voluntariness can be said to have a significant effect on perceived usefulness because it has a p value smaller than 0.05.

11 Perceived Ease of Use to Intention to Use

Based on the test results in the first hypothesis, it was found that perceived ease of use had a significant effect to intention to use on E-Ticketing system users on TripAdvisor at Solid Travel. Perceived ease of use by voluntariness can be said to have a significant effect on perceived usefulness because it has a p value smaller than 0.05.

12 Intention to Use to Usage Behavior

Based on the test results in the first hypothesis, it was found that intention to use had a significant effect usage behavior on E-Ticketing system users on TripAdvisor at Solid Travel. Intention to use by voluntariness can be said to have a significant effect on perceived usefulness because it has a p value smaller than 0.05.

5 CONCLUSIONS & RECOMMENDATIONS

5.1 Conclusions

Some conclusions related to the previous discussion regarding analysis of trip advisor acceptance in Indonesia using technology acceptance model 2: case study of e-ticketing in solid travel consumers, including:

1. Subjective norms have significant effect to the image of E-Ticketing users on TripAdvisor meaning that if the subjective norms of system use continue to increase it can affect the user's image in the future.
2. Image have significant effect to the perceived usefulness of E-Ticketing on TripAdvisor means that if the system image continue to improve, it can affect the perceived usefulness in the future.
3. Job relevance have significant effect to the perceived usefulness of E-Ticketing on TripAdvisor, meaning that the relevance of work from the use of the system continues to increase so it can affect the perceived usefulness in the future.
4. The output quality have significant effect to the perceived usefulness of the E-Ticketing on TripAdvisor meaning that if the output quality from the use of the system continues to increase, it can affect the perceived usefulness in the future.
5. Result demonstrability have significant effect to the perceived usefulness of E-Ticketing on TripAdvisor, meaning that the result demonstrability of the use of the system continues to increase, it can affect the perceived usefulness in the future.
6. Subjective norm moderated by experience have significant effect to the perceived usefulness of E-Ticketing on TripAdvisor meaning that if subjective norm that are moderated by experience from the use of the system continue

to be improved it can affect the perceived usefulness in the future.

7. Subjective norm that are moderated by experience have significant effect to the intention to use on TripAdvisor meaning that if subjective norm that are moderated by the experience of using the system continue to be improved it can affect intention to use in the future.
8. Subjective norm that are moderated with voluntariness have significant effect to the intention to use of E-Ticketing users on TripAdvisor means that if subjective norm that are moderated with voluntariness from the use of the system continue to be improved it can affect intention to use in the future.
9. Perceived ease of use have significant effect to the perceived usefulness of E-Ticketing on TripAdvisor means that if perceived ease of use of the system continues to be improved it can affect future perceived usefulness.
10. Perceived usefulness have significant effect to intention to use of E-Ticketing users on TripAdvisor means that if perceived usefulness of using the system continue to be improved it can affect intention to use in the future.
11. Perceived ease of use have significant effect to intention to use of E-Ticketing users on TripAdvisor meaning that if perceived ease of use of the system continues to be improved it can also affect intention to use in the future.
12. Intention to use have significant effect to usage behavior of E-Ticketing on TripAdvisor meaning that if intention to use is increased it will affect usage behavior in the future.

5.2 Recommendations

Based on research that has been done, suggestions that can be taken into consideration for research and also for future companies are as follows:

1. Practical Recommendation
 - a) Paying attention to the content and appearance of websites and applications to be regularly updated, keep updating information to be more accurate, adding package options to the website and removing information that is not used.
 - b) Creating a system that is simple but still clear so that it can be understood by all people, so the system will be easily mastered by the user.

- c) Continuing to update and improve the quality of the system will increase user interest in continuing to use this system in the future.
- d) Maintaining better service quality so that users continue to use the e-ticketing system on TripAdvisor and not move to other applications. By the way the system must be unique both in terms of design and appearance have good navigation in cultivating the use of digital applications that can provide benefits for users so that old habits will be eliminated when there is no other choice but to use the digital application.

2. Theoretical Suggestions

The author suggests that future studies be analysed using the latest models such as TAM 3 or can modify the conceptual model. In addition, it is expected that further research can take extensive samples so that the results obtained are more accurate in accepting the E-Ticketing website on TripAdvisor on Solid Travel.

ACKNOWLEDGEMENTS

Thanks are addressed to Director, all of staff and the customers of PT Lim Lee Solid Indonesia who has given the opportunity to the writer to research and be able to implementation system information in this company.

REFERENCES

- Alhabsyi, F. A., Astuti, E. S., & Riyadi, R. (2018). Kesuksesan Implementasi E-Ticketing (Studi Kasus Pada Pt. Kereta Api Indonesia (Persero) Tentang Business To Customer Di Stasiun Kota Malang).
- Likert, R. (1932). A Technique for the Measurement of Attitudes. publisher not identified.
- Solimun. (2006). Penggunaan Structural Equation Modeling (SEM) Dalam Penelitian. Universitas Brawijaya, Malang.
- Sugiyono. (2013). Metode Penelitian Kuantitatif, Kualitatif, dan R&D. Bandung: CV Alfabeta.
- Venkatesh, V., & Davis, F. D. (2000). A theoretical extension of the technology acceptance model: Four longitudinal field studies. Management Science.