

# Thermodynamic Analysis of Cascade Refrigeration System using CO<sub>2</sub> – NH<sub>3</sub> Refrigerant for Fish Cold Storage Application

Nazaruddin Abubakar<sup>1</sup>, Sutopo Purwono Fitri<sup>1</sup>

<sup>1</sup> Department of Marine Engineering, Faculty of Marine Technology, Technology Institute of Sepuluh Nopember, Surabaya

Keywords: Thermodynamic, cascade, refrigeration, cold storage, CO<sub>2</sub>, NH<sub>3</sub>

Abstract: The adverse effects on the earth's atmosphere due to the use of non-environmentally friendly refrigerants have increased significantly which has resulted in an increase in Ozone Depletion Potential (ODP) and Global Warming Potential (GWP). This phenomenon encourages industries to use natural alternative refrigerants such as ammonia (NH<sub>3</sub>) and carbon dioxide (CO<sub>2</sub>). The application of a cascade refrigeration system that uses CO<sub>2</sub> refrigerant on the Low-Temperature Circuit (LTC) and NH<sub>3</sub> on the High-Temperature Circuit (HTC) becomes an excellent alternative to the application of fish freezing at low temperatures. In this paper, a cascade refrigeration system with CO<sub>2</sub> working fluid on the LTC and NH<sub>3</sub> on the HTC have been analyzed. Design and operation parameters considered in this study include evaporation temperature, a temperature difference in the cascade heat exchanger, condensation temperature, suction and discharge pressure on the system.

## 1 INTRODUCTION

Refrigeration systems have played a very important role in everyday life. The development of technology in the field of refrigeration provides many benefits for human needs. In the industrial world, refrigeration systems are used for the storage and distribution of food ingredients, so that the quality and freshness can be maintained for several weeks until the time they are needed to be distributed to consumers. One type of food product whose quality and freshness needs to be maintained is fishery products.

Fishery products are food that is easily damaged. Post-harvest handling greatly determines the quality and durability of the fish. According to reference (Handayani et al, 2014), basically, handling and processing of fish aim to prevent damage or decay. Efforts are being made to extend the duration of storing fresh fish which is stored in cold storage.

Cold storage is a room that is used to store fishery products that require cold temperatures. Cold storage has a larger room size than other refrigerators with room temperature ranging from 15°C to -45°C.

This very low temperature range can be met by a one-level refrigeration system with one compressor, many pressurized systems that use more than one compressor such as multilevel refrigeration systems and a combination of two or more single refrigeration systems (cascade), where the first system is a High-Temperature Circuit (LTC) and others as Low-Temperature Circuit (LTC). A cascade refrigeration system is the best way to get power savings and increase the coefficient of performance (COP). The advantages of the cascade refrigeration system can still be enlarged to produce very low temperature conditions and save power. One way is to use different types of refrigerants on each circuit.

Environmental problems related to Ozone Depletion Potential (ODP) and Global Warming Potential (GWP) caused by the use of synthetic refrigerants (CFC's, HCFC's and HFC's) that have occurred in recent decades, makes the effort to reuse natural substances as refrigerants are rational. This will be a better solution for using environmentally friendly substances as alternative refrigerants in

refrigeration systems (Dopazo et al, 2009). The natural refrigerant is a substance that occurs through a biochemical process and does not have an adverse effect on the environment, but some of them have side effects for users such as being exposed to high toxicity and flammability. Natural refrigerants commonly used are water, air, noble gases, hydrocarbons, ammonia, and carbon dioxide.

As a natural refrigerant, ammonia is very suitable to replace CFCs and HCFCs in modern refrigeration systems. In terms of environmental aspects, ammonia is the most acceptable refrigerant and a long-term alternative, because its release into the atmosphere has no impact on ozone depletion (ODP = 0) or greenhouse effect (GWP = 0) (Jankovich & Osman, 2015). Whereas carbon dioxide has emerged as a credible natural refrigerant to replace HFCs in retail food applications. CO<sub>2</sub> is non-combustible and non-toxic, it has no impact on ozone depletion (ODP = 0) and negligible global warming potential (GWP = 1). CO<sub>2</sub> has favorable thermophysical properties such as high density, specific heat, volumetric cooling capacity, latent heat and thermal conductivity (Tsamos et al, 2017).

The application of natural refrigerants NH<sub>3</sub> and CO<sub>2</sub> as working fluids in cascade refrigeration systems is an excellent alternative to very low temperature cooling applications. With a cascade refrigeration system, NH<sub>3</sub> which is quite toxic will separate from the cooling chamber so that it will improve the safety of workers, property and refrigerated products. The use of CO<sub>2</sub> is currently well received in the industry and in large commercial cooling systems where it is used as a refrigerant in the NH<sub>3</sub>/CO<sub>2</sub> cascade refrigeration system with a temperature range between -10°C to -50°C. CO<sub>2</sub> provides great electricity savings, excellent energy efficiency, and has a good heat transfer coefficient.

Some researchers have evaluated the thermodynamic performance of a cascade refrigeration system. Getu and Bansal have thermodynamically analyzed the cascade carbon dioxide-ammonia refrigeration system (R744-R717) to optimize the evaporation temperature of the R717 and its mass flow rate, which can provide a maximum COP of the system (Getu & Bansal, 2008). Rawat et al. analyzed thermodynamic cascade refrigeration systems that use NH<sub>3</sub> on HTC and CO<sub>2</sub> on LTC, to determine the effect of various types of design and operating parameters which include condenser temperature, evaporator temperature, coupling temperature, compressor isentropic efficiency and temperature difference in the cascade heat exchanger, the influence of subcooling and superheating was also

investigated (Rawat et al, 2015). Messineo thermodynamically analyzed the cascade refrigeration system (R744-R717) based on operating parameters, then the results were compared with the thermodynamic analysis of a two-stage refrigeration system using R404A refrigerant (Messineo, 2012). However, there is still a lack of research analyzing the effect of several operating parameters on the coefficients of the performance of the system and the work required by the compressor of each circuit. Therefore, this study aims to analyze the effect of the operating parameters of the cascade refrigeration system on the COP cascade system and the work required by the HTC and the LTC. The effect of operating parameters on the mass flow rate of refrigerant was also analyzed in this study.

## 2 SYSTEM DESCRIPTION

A schematic diagram of a cascade refrigeration system for fish cold storage is shown in Figure 1. This system consists of two units of vapor compression refrigeration systems that work separately with different refrigerants. The system consists of several components such as a compressor, evaporator, condenser, cascade condenser, cascade evaporator, expansion valve, etc.

Low-Temperature Circuit (LTC) that using Carbon dioxide as a refrigerant and High-Temperature Circuit (HTC) that using Ammonia as a refrigerant, are thermally connected by cascade heat exchanger and it is assumed that the cascade heat exchanger is perfectly insulated, kinetic energy and potential is neglected. heat transfer from the fluid in LTC must be the same as heat transfer to fluid on HTC.

The Evaporator on HTC which has a relatively higher temperature is used to absorb heat in the LTC condenser so that the evaporator at LTC has a lower temperature.

The cascade system is very effective when very low temperature refrigeration is needed. The cascade system allows the use of different refrigerants depending on the work pressure and type of compressor to be used.

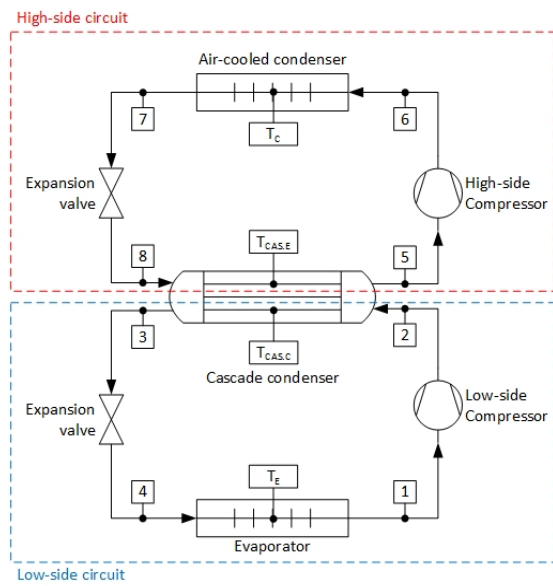

Figure 1: Schematic diagram of a cascade refrigeration system.

As shown in the T-s diagram in Figure 2, the compressor's work decreases, and the amount of heat absorbed from the refrigerated increases as a result of cascading. Therefore, cascading improves the COP of the refrigeration system.

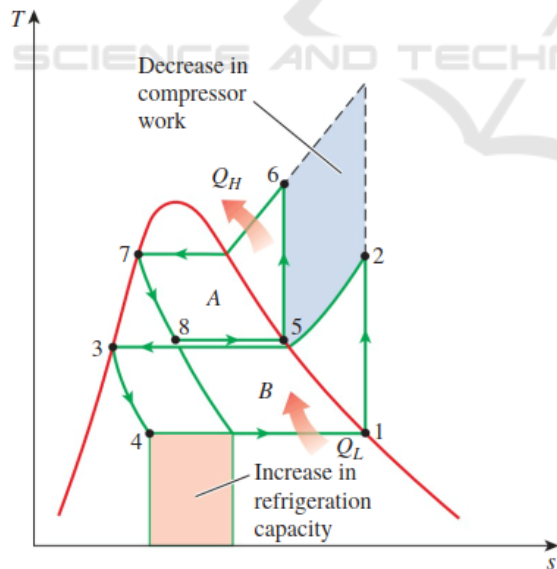

Figure 2: Cascade refrigeration system cycles on T-s property plots. [8]

### 3 NUMERICAL MODEL

#### 3.1 Mathematical Modelling

The mathematical model of the cascade refrigeration system has been designed to simulate mass and energy balances on each one of the components of the entire system.

Thermodynamic analysis of the cascade refrigeration system is based on the assumptions below:

1. The system is in a steady-state and steady-flow state.
2. Changes in kinetic and potential energy are negligible.
3. The compressor isentropic efficiency is constant.
4. The cascade heat exchanger and piping are completely insulated.

Thermodynamic analysis of the cascade refrigeration system in this study is based on the cooling load ( $Q_E$ ) of cold fish storage that is equal to 76.21 kW, while for the operating parameters of the designed cascade refrigeration system are as follows:

- evaporator temperature ( $T_E = -30^\circ\text{C}$ ),
- condenser temperature ( $T_C = 40^\circ\text{C}$ )
- and cascade condenser temperature ( $T_{CAS} = -5^\circ\text{C}$ ).

The temperature difference in the cascade condenser is assumed to be ( $\Delta T_{CAS} = 5 \text{ K}$ ).

#### 3.2 Thermodynamic Analysis

Thermodynamic analysis of a cascade refrigeration system has been carried out by simulating the thermodynamic state of the refrigerant.

The thermophysical properties of Ammonia and Carbon dioxide refrigerants are calculated using software called Engineering Equation Solver (EES) (EES, 2013), which has a property function of many types of refrigerants.

Simulations of various design parameters such as evaporator temperature, condenser temperature, and cascade condenser temperature variations are carried out with parametric table features that can perform calculations quickly and accurately.

Based on the assumptions that have been made previously, the following is a series of calculations used for thermodynamic analysis of a cascade refrigeration system.

The capacity of the evaporator is determined from:

$$\dot{Q}_E = \dot{m}_L(h_1 - h_4) \quad (1)$$

Compressor power consumption for the HTC is defined by:

$$\dot{W}_H = \dot{m}_H(h_6 - h_5) \quad (2)$$

Whereas for the LTC, it is defined by:

$$\dot{W}_L = \dot{m}_L(h_2 - h_1) \quad (3)$$

The rate of heat transfer in the cascade heat exchanger is given by:

$$\dot{Q}_{CAS} = \dot{m}_L(h_2 - h_3) = \dot{m}_H(h_5 - h_8) \quad (4)$$

The mass flow ratio can be derived from Eq. (4):

$$\dot{m}_H / \dot{m}_L = \frac{h_2 - h_3}{h_5 - h_8} \quad (5)$$

The rate of heat rejection by the condenser is defined by:

$$\dot{Q}_H = \dot{m}_H(h_6 - h_7) \quad (6)$$

The overall COP of the system is determined by:

$$COP = \frac{\dot{Q}_E}{\dot{W}_H + \dot{W}_L} \quad (7)$$

## 4 RESULT AND DISCUSSION

### 4.1 Effect of Evaporator Temperature

The temperature of the evaporator ( $T_E$ ) was varied from -25°C to -45°C by keeping the condenser temperature and the cascade condenser temperature at the operating design parameters.

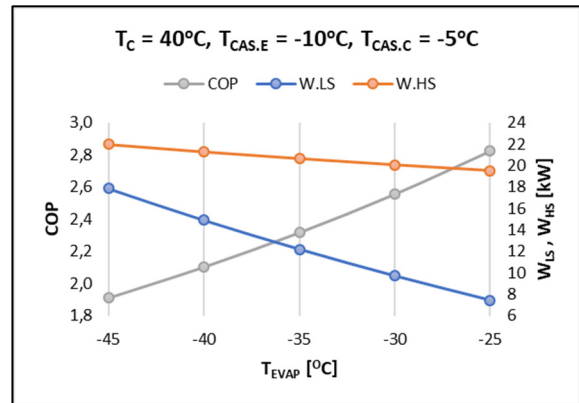

Figure 3. System performance and compressor work with variations in evaporator temperature.

Figure 3 shows the effect of the evaporator temperature change on the work required by LTC compressor ( $W_{LS}$ ), HTC compressor ( $W_{HS}$ ) and the coefficient of performance (COP) of the cascade refrigeration system.

As the evaporator temperature increases, the COP of the system increases significantly, therefore the work required by the LTC compressor decreases significantly, but the work required by HTC compressor is only slightly decreased.

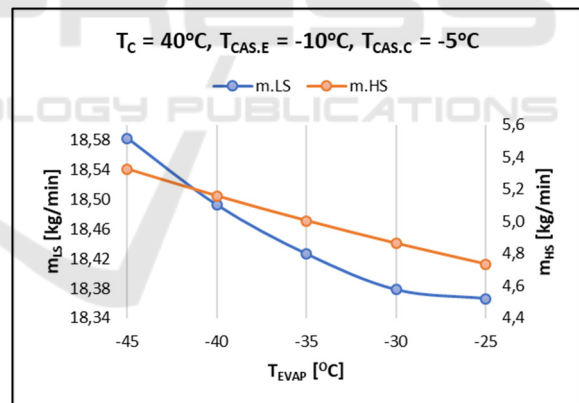

Figure 4. Mass flow rate of refrigerant with variations in evaporator temperature.

The effect of the temperature change of the evaporator on the mass flow rate on the LTC and HTC is described in Figure 4.

As the evaporator temperature increases, the mass flow rate of the refrigerant on HTC decreases constantly and significantly, while the mass flow rate on the LTC initially decreases significantly but then decreases slightly.

### 4.2 Effect of Condenser Temperature

The temperature of the condenser ( $T_C$ ) was varied from 30°C to 50°C by holding the evaporator temperature and the cascade condenser temperature at the operating design parameters.

The effect of the condenser temperature changes on the work required by the LTC compressor and the HTC compressor has been analyzed (see Figure 5).

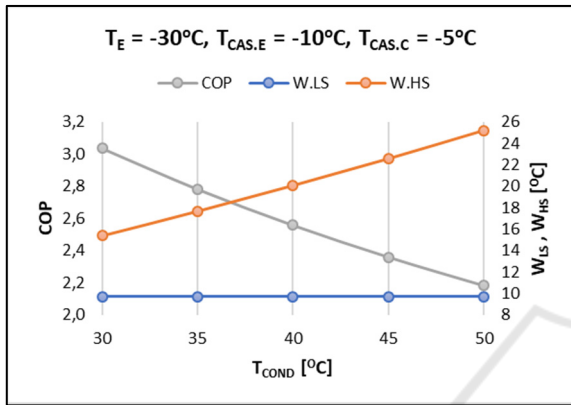

Figure 5: System performance and compressor work with variations in condenser temperature.

As the condenser temperature increases, the work required by the HTC compressor increases significantly, while the COP of the cascade system decreases significantly, while the condenser temperature changes have no effect on the work required by the LTC compressor.

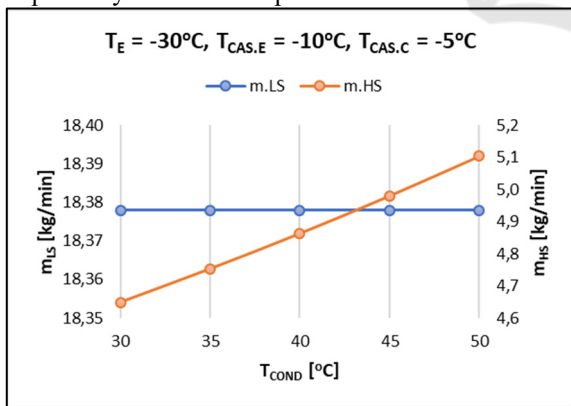

Figure 6: Mass flow rate of refrigerant with variations in condenser temperature.

Figure 6 shows the effect of changes in the temperature of the condenser on the mass flow rate on the LTC and the HTC.

The mass flow rate of refrigerant on the HTC increases significantly as the condenser temperature increases, while the mass flow rate of refrigerants on the LTC is not affected by changes in condenser temperature

### 4.3 Effect of Cascade Condenser Temperature

The temperature of the cascade heat exchanger ( $T_{CAS}$ ) has varied from 5°C to -5°C by keeping the temperature of the evaporator and the condenser temperature at the operating design parameters.

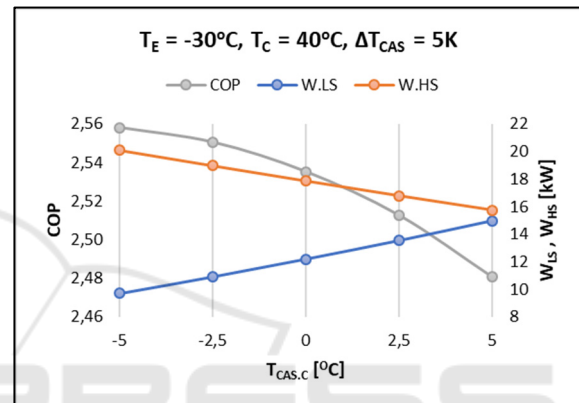

Figure 7: System performance and compressor work with variations in cascade condenser temperature

The effect of changes in the cascade heat exchanger temperature on the work required by the LTC compressor and the HTC compressor illustrated in Figure 7. The results show that as the cascade heat exchanger temperature increases, the work required by the LTC compressor increases, while the work required by HTC compressor tends to decrease. therefore, the cop of the cascade system decreases.

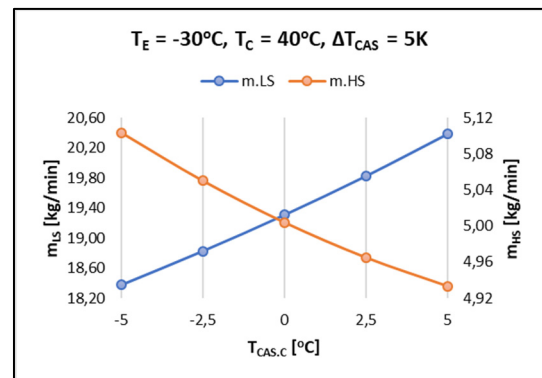

Figure 8: Mass flow rate of refrigerant with variations in cascade condenser temperature.



The effect of the cascade condenser temperature changes on the mass flow rate is shown in Figure 8. As the cascade condenser temperature increases, the mass flow rate on the LTC increases while the mass flow rate on the HTC decreases.

## 5 CONCLUSIONS

In this study, thermodynamic analysis of the cascade refrigeration system presents the use of Carbon dioxide (CO<sub>2</sub>) on the LTC and Ammonia (NH<sub>3</sub>) on the HTC. This analysis leads to the following conclusions:

1. An increase in the temperature of the evaporator produces an increase in the COP and decreases both the work required by the compressor and the mass flow rate.
2. An increase in condenser temperature results in a decrease in COP and an increase in the mass flow rate and work required by the compressor on the HTC.

An increase in the cascade heat exchanger temperature results in an increase in the mass flow rate and work required by the compressor on the LTC but decreases the mass flow rate and the work required by the compressor on the HTC. Therefore, the COP cascade system tends to decrease.

## REFERENCES

- Bansal, P. K. & Getu, H. M., 2008. *Thermodynamic analysis of an R744–R717 cascade refrigeration system*, Volume 31, p. 45–54.
- Cengel, Y. A. & M. A. Boles, 2015. *An Engineering Approach*. 8th ed. McGraw-Hill Education. New York.
- Dopazo, J. A., Fernandez-Seara, J., Sieres, J., Uhia, F. J., 2009. *Theoretical analysis of a CO<sub>2</sub>–NH<sub>3</sub> cascade refrigeration system for cooling applications at low temperatures*, 29(8–9), p. 1577–1583.
- EES., 2013. *Engineering Equation Solver*, s.l.: fChart Software Inc.
- Handayani, A., Alimin, A., Rustiah, W. O., 2014. *Effect of Storage at Low Temperature (Freezer -30C) on Water Content and Fat Content in Lemuru Fish (Sardinella longiceps)*, 2(1), p. 64–75.
- Jankovich, D. & Osman, K., 2015. *A feasibility analysis of replacing the standard ammonia refrigeration device with the cascade NH<sub>3</sub>/CO<sub>2</sub> refrigeration device in the food industry*, 19(5), p. 1821–1833.
- Messineo, A., 2012. *R744-R717 cascade refrigeration system: performance evaluation compared with a HFC two-stage system*. s.l., s.n.

- Rawat, K. S., Kshetri, R., Khulve, H., Pratihari, A. K., 2015. *Parametric study of R744-R717 cascade refrigeration system*, Volume 2.
- Tsamis, K. M., Y. T. Ge., Santosa, I., Tassou, S. A., Bianchi, G., Mylona, Z., 2017. *Energy analysis of alternative CO<sub>2</sub> refrigeration system configurations for retail food applications in moderate and warm climates*, p. 822–8.