

Research on the NC Maching Toolpath Tstrategy of Complex Curve Surface

Zhu ming Cao ¹, Lu Lu ¹, Kun Qiu ¹, Dongying Zhang ¹ and Jiatian Guo ²

¹.School of Mechanical Engineering, Beijing Polytechnic, Beijing 100176, China;

².Department of Automotive Engineering, Shandong Vocational College of science and technology, Shandong Weifang 261053, China

Keywords: Complex curve surface; NC machining; Tool path; Cutter axis vector; optimize.

Abstract: With the progress of science and technology and the personalized needs of users, complex curve surface has been widely used in aerospace, ship, vehicle, molds, medical devices and other industries. Efficient and precise manufacturing of complex curve surfaces is an important research direction of the advanced manufacturing technology. This paper research the NC machining tool path for a complex curve surface, and for the feature of the surface to choose the variable contour milling strategy. Optimization of the cutter axis vector, achieve the projection from cutting point of the cutter to the cutter axis is the largest when cutting the surface. So as to achieve the maximum cutting speed and improve the surface quality. This paper constructs the change model of the cutter axis vector of the cutting process, and the optimization of the rotation angle of the cutter axis vector is completed. The design and precision requirements, high surface quality and precision can be obtained by using this strategy and model.

1 INTRODUCTION

With the progress of the personalized needs of users, complex curve surface has been widely used in aerospace, ship, vehicle, molds, medical devices and other industries. Common products include impeller blades for aero engines, propellers in ships, turbines for vehicle engines, etc. The machining of these surfaces requires a complex cutting motion between the cutter and the workpiece on the multi-axis NC machine tool. The NC machining technology determines the machining accuracy and the machining efficiency of these complex curve surface parts, thus affecting their performance. The key and difficulty of complex curve surface machining is the process of computer aided manufacturing. Professional, efficient, safe and intelligent CAM software must be used. And the processing technology, precision and efficiency can be embodied in the tool path through computer assistance. Therefore, the research on the machining technology of complex curve surface is focus on the research of the path of the machining tool, and the tool path planning has a direct

impact on the machining efficiency and precision of the parts.

As shown in Fig 1-a, the mainly work of the tool path planning of the complex curve surface is determination of the completion of the cutter site and the cutter axis vector. Cutting position is selected by a driver, and based on the determined projection vector, the cutter location point is created by making the driving point generated on the drive to project onto the component geometry by the specified projection vector. As shown in Fig 1-b. The tool axis vector setting refers to the tool axis pointing in the machining process to move according to certain strategies. Commonly used strategies of the knife shaft include away from point, orient to point, away from straight line, orient the straight line, perpendicular to the driver, relative to the driver, interpolation vectors, four axis perpendicular to the driver and four axis relatives to the driver body, etc. When machining complex curve surfaces, it is usually necessary to have multiple cutting tools to complete. In theory, only pass the three steps of cutting point

positioning, cutting tool path planning and collision inspection, then be sure non-interference tool path, it can be done. The main process of tool path generation is: ① determine the tool positioning strategy, realized the maximization of machining line width without over-cutting; ② determine the method to generate the knife path, calculate row spacing, walking distance, cutting depth and other parameters, to minimize the total length of tool path in the premise of ensuring the continuity and smoothness of the knife road; ③ avoid the interference of tools with workpieces and fixtures with workbenches. These three aspects are mutually complementary and closely related. In the actual processing, we should consider the tool positioning, the axial vector light, the shape of the knife, the length of the tool, the machining parameters, the interference and the characteristics of the machine movement, etc. It is the difficulty of complex curve surface machining. Therefore, most research on tool path planning is limited in several aspects. In this paper, we research the cutter axis strategy of "four-axis relative to drive". This strategy is used to construct the change model of the cutter axis, optimize the relevant parameters, and complete the efficient and precise manufacturing of a complex curve surface.

2 RESEARCH ON THE STRATEGY OF "4-AXIS RELATIVE TO THE DRIVER"

The "4-axis relative to the driver" is a commonly used tool path strategy in the four-axis CNC machining process, and it is widely used in the manufacture of mould, blade and aviation parts. This cutter axis strategy adds a "front rake Angle" and an "side inclination Angle" based on the "4-axis perpendicular to the component" tool axis strategy to make the cutter shaft more flexible and reliable, as shown in Fig2. The cutter axis strategy requires the cutter axis to be perpendicular to the driver or machining surface, and the plane projection which is perpendicular to the axis rotation Angle X. Then it can set the front rake Angle, side inclination Angle and rotation Angle to adjust the direction of the axis vector to meet the processing demand of various curved surfaces. The operation mode of the 4-axis relative to the driver is: Select 4-axis relative to the driver as the cutter axis strategy; then define the connection of two points as the axis of rotation; at last input the desired 4 axis rotation Angle, front rake Angle and side inclination Angle.

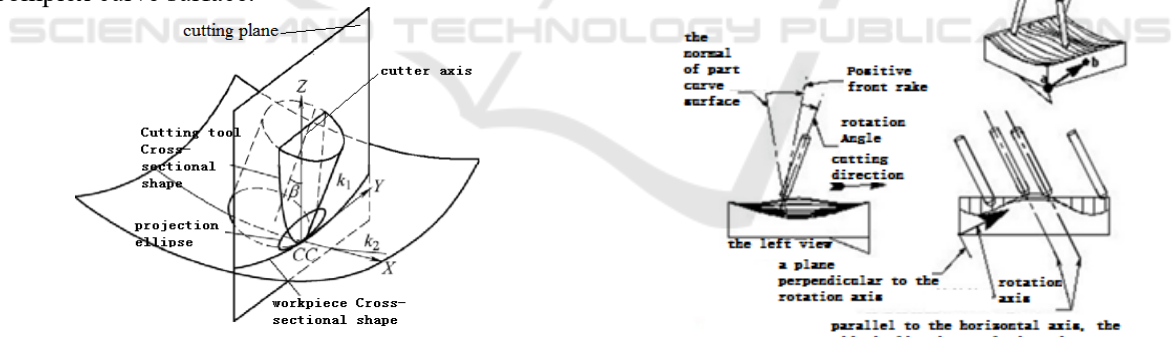

(a) The principle of cutter location algorithm

Fig2 the strategy of "4-axis relative to the driver".

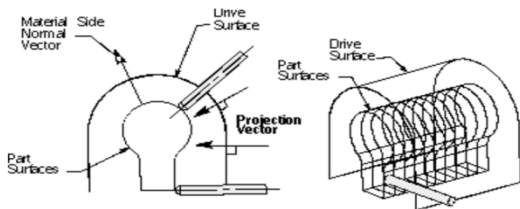

(b) cutter location point generation principle

Fig1 generating tool path of the complex curve surface.

As shown in Fig2, the main parameters of the strategy of 4-axis relative to the driver include rotation axis vector, front rake Angle, side inclination Angle and rotation Angle. The rotation axis vector refers to the vector direction of the rotation axis in the parts during the four-axis machining process; The front rake refers to the cutter axis tilted toward the direction of the cutter, it is affected by the direction of the tool

movement. The forward refers to the slope along the direction of the tool path-Pull the walk, the reverse refers to the reverse direction of the tool path- push the walk, it is based on the vertical face of the walking knife. The rotary surface of the cutter is perpendicular to the direction of the cutter when the cutter side inclination. Looking back the first cutter feed direction, counter clockwise is positive, clockwise is negative, it is based on the direction of the walking cutter to calculate the Angle. The rotation Angle makes all the axes revolve around the defined rotation axis, at the same time, keep the tool perpendicular to the rotation axis. Looking from the direction of the positive side of the rotation axis to the negative, counter clockwise is positive, clockwise is negative. Unlike the "front rake Angle", the four-axis rotation Angle is always tilted to the same side of the normal axis, which has nothing to do with the direction of the cutter movement.

As shown in Fig3-b, When the direction of the cutter is perpendicular to the rotation axis X, the cutter axis can only be set forward and rotated, and the setting side inclination is invalid. In order to avoid the swing of the cutter axis too often, the "one-way" strategy is set in the drive. As shown in Fig3-c, When the direction of the cutter is parallel to the axis of rotation, the axis of the cutter can only set the side inclination Angle and rotation Angle, and the front inclination is invalid, and the effect of setting the side inclination Angle and rotation Angle is the same, and the lateral inclination cannot be greater than 90, otherwise the cutter path is invalid. From the positive side of the rotation Angle vector looks forward to negative direction, counter clock wise is positive, clockwise is negative. The rotation Angle vector is calculated by the angular reference based on the rotation vector.

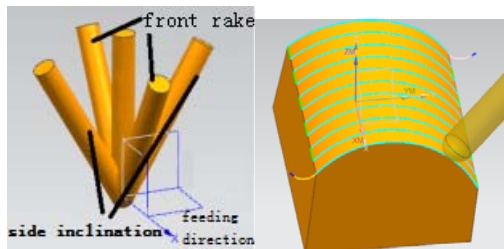

(a) front rake and side inclination (b) perpendicular to the rotation axis

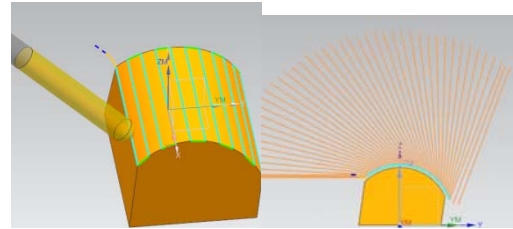

(c)parallel to the side inclination (d) rotation axis rotation axis

Fig3 cutter axis vector parameters.

3 APPLICATION RESEARCH ON 4-AXIS RELATIVE TO THE DRIVER

As shown in Fig4-a, the specimen in this paper is a curved camshaft. The side curve surface of the part and the hub need to use the four-axis NC machining. The planning of tool path is required before processing, including the setting of cutter site and cutter axis vector. The tool path of the lateral surface adopts the variable contour milling strategy of UG10.0, machined surface selects the processed surface; the projection vector is perpendicular to the driver, the cutting mode is reciprocating, the tolerance is set to 0.01, the cutter point will be generated in the normal direction of each point of the surface, as shown in Fig4-b; the cutter axis is selected on the 4 axis relative to the driver, when all the parameters are set to 0, generated the cutter axis as shown in Fig4-c, it can be found that the cutter axis interferes with the hub of the camshaft, therefore, the tool path should be optimized.

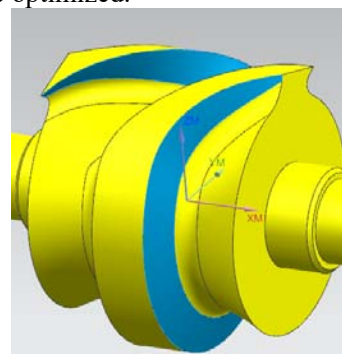

(a) the surface of the driver

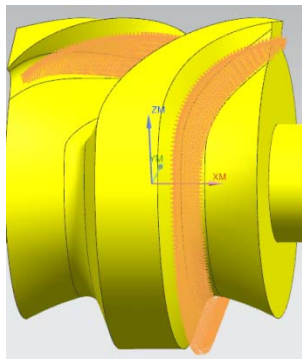

(b) the cutter point cloud

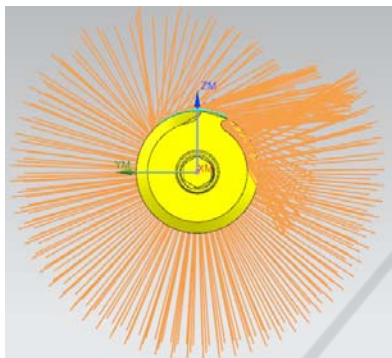

(c) cutter axis vector

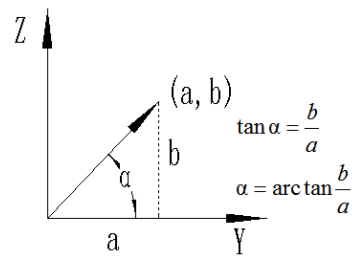

(a) cutter axis vector



(b) test pieces

Fig5 4 axes relative to the driver.

Fig4 design the tool path for the curve surface of cam.

Because the rotation axis A of the component is rotated around the X-axis, the cutter axis can only rotate around the X-axis, so the rotation Angle α of the cutter axis is the Angle that is perpendicular to the driver at the cutter point, and projection on the YZ plane, the Angle formed with the Y-axis, as shown in Fig5-a. The cutter axis can be interfered when the cutter axis parameter is not set. Therefore, it is necessary to optimize the cutter axis vector. This paper research the tool path of the side curve surface of the part, and design the maximum cutting speed to be achieved without interference.

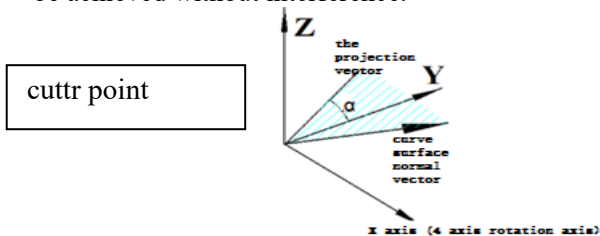

4 AXIS VECTOR OPTIMIZATIONS

To ensure the smoothness of the curved surface, according to the cutting speed $V = \omega R1$ ($R1$ is the vertical distance from the spher mill cutting point to the cutter shaft), it should be ensured that $R1$ is the largest during processing, this will achieve maximum cutting speed. Suppose the space plane is a $X+bY+cZ+D=0$, the normal vector is (A,B,C) , so the space line can be represented as two planes simultaneous. The result of the simultaneous expression can be expressed θ as the determinant, as shown in formula 1; according to the spatial linear two points, as shown in formula 2; the normal vector of each point after cutting is $\vec{a}_f = (x_f, y_f, z_f)$, The tool vertical it; the normal vector for each point before cutting is $\vec{a}_0 = (x_0, y_0, z_0)$; therefore, the change of the normal vector per cutting is $(x_0, y_0, z_0), \dots, (x_n, y_n, z_n)$; if once reciprocate can complete processing, then the Angle formula

of $\vec{a}_f = (x_f, y_f, z_f)$ and $\vec{a}_0 = (x_0, y_0, z_0)$ is as shown in formula 3, the fastest cutting speed V can be calculated by formula 4, 5 and 6. According to the algorithm, use the software verify that the θ value can be 63.476° -- 78.889° . In this case, the rotation Angle θ is selected as 70° , the higher surface quality can be obtained through trial production, as shown in Fig5-3

$$\frac{x - x_0}{a} = \frac{y - y_0}{b} = \frac{z - z_0}{c} \quad (a, b, c \text{ is the direction of the vector}) \quad \textcircled{1}$$

$$\frac{x - x_1}{x - x_2} = \frac{y - y_1}{y - y_2} = \frac{z - z_1}{z - z_2} \quad (a, b, c \text{ is the direction of the vector}) \quad \textcircled{2}$$

$$\cos\theta = \frac{\vec{a}_f \cdot \vec{a}_0}{|\vec{a}_f| |\vec{a}_0|} \quad (\vec{a}_f, \vec{a}_0 \text{ is unit vector}) \quad \textcircled{3}$$

$$\cos\theta = \vec{a}_f \cdot \vec{a}_0 = (x_f, y_f, z_f) \cdot (x_0, y_0, z_0) = x_f x_0 + y_f y_0 + z_f z_0 \quad \textcircled{4}$$

$$\theta = \arccos(x_f x_0 + y_f y_0 + z_f z_0)$$

(R is radius of spher mill for machining) $\textcircled{5}$

$$R_1 = R \cdot \sin\theta = R \cdot \sqrt{1 - \cos^2\theta} = R \cdot \sqrt{1 - (x_f x_0 + y_f y_0 + z_f z_0)^2} \quad \textcircled{6}$$

5 CONCLUSIONS

This paper research the cutter axis vector in the machining process of camshaft side wall curve surface. The tool path strategy of the curved surface adopts the variable contour milling of UG12.0; to maximize processing speed, the direction of cutter axis vector is optimized, and ensure that the cutting tool's cutting position is as large as the vertical distance from the cutter shaft. In this paper, the change process model of the cutter axis vector of the cutting process is

constructed, and the optimization of the rotation Angle of the cutter axis vector is completed. It can obtain high surface quality and precision by using this strategy and model, and achieve the design and precision requirements. At the same time, we should pay attention to not selecting geometry in the setting process of the tool path for sidewall curve surface, otherwise, we cannot generate the tool path that revolves around the X-axis. In the process of actual processing, it is necessary to adjust the position reference alignment for the work blank to ensure the unification of the design standard and the clamping standard.

REFERENCES

1. Chen Guang-ming. The principle and method study of technological design based on NC machining[J]. Manufacturing Automation 2005, 27(9): 54-59, 72.
2. Gui Qun-fei. CAD/CAM technique of ship model numerical control machining based on UG[D]. Wuhan: Huazhong University of Science & Technology, 2005.
3. Zhao Yan-hua, LI Wei-long, Dong Xiao, etc. Application of variable axis curved contour milling in special thin wall part machining[J]. Aeronautical Manufacturing Technology, 2008(16): 87-90.
4. Wang Xian-kui. Modern manufacturing technology and its development trend [J]. Modern manufacturing engineering, 2008, (1): 1-8.
5. LI Chao. The Research of Five-axis Numerical Control Machining Programming[J]. Machinery Design & Manufacture, 2009 (01) : 60-62.
6. CHENG Wei, ZHANG Yue-ming, BU Fang-hua. Study on the CNC processing of globoidal cam[J]. MACHINERY DESIGN & MANUFACTURE, 2011(03): 171-173.
7. CAO Ju-lu, ZHANG Shu-sheng, SHI Yun-fei, FAN Hai-tao, YANG Yan. A process route simulation method of parts cutting[J]. Machinery Design & Manufacture, 2011(03): 171-173.
8. Hu Zi-hua, Zhang Ping, Qi Rui. A Study on Multi-axis NC Machining Processes for Continuous Indexing Globoidal Cams[J]. China Mechanical Engineering, 2005(24): 2184-2187.
9. (FAN Wengang YE Peiqing. Research Progress in Tool Path Planning for Five-axis End Milling Machining of Sculptured Surfaces[J]. Journal of Mechanical Engineering, 2015(08): 168--182.
10. YANG Yong-sheng, Wang Min. An Algorithm for Interference Free Tool Path Generation in NC Machining[J]. Aeronautical Manufacturing Technology, 1998(12): 9-11.