

Agility Test Development Based Infrared Sensor

Ryan Budi Prakoso, Luqman Hardiansyah, M. Latif and Agus Rusdiana
Universitas Pendidikan Indonesia, Jl. Dr. Setiabudhi No. 229, Bandung 40154, Indonesia
luqman.hardiansyah@student.upi.edu

Keywords: Agility Test, Research and Development (R&D), Infrared Sensors.

Abstract: The purpose of this study was to develop agility measuring instruments such as shuttle run, 505 agility, zig-zag, t test and Illinois based laser sensor. This tool is capable of being adjusted in several agility tests that results in units of time. Working system is supported by laser sensors to detect motion and microcontroller as an interpretation of sensor detection results whose output is raised through seven segments. The counter will begin to calculate the time when the test performer passes the sensor, not by instruction. Research and development method used in this research, because this research develops and produces a prototype product. Validity was tested by comparing the agility test results using the sensor using the stopwatch test, while the reliability was tested by comparing the retest results with the sensor agility. Validity test shows the value of pearson correlation of 0.784 means there is a high correlation between the test using sensors and without sensors. Reliability test shows sig value. (2-tailed) of 0.781 means there is no difference between the initial test and the final test, meaning the tool can steady. The results showed the average value of the test using the sensor faster, because it is more accurate than using a stopwatch which results depend on the testers.

1 INTRODUCTION

Agility is the ability of the body to move quickly and change direction with a short time (Sheppard and Young 2006). Many field sports require agility in games such as football, rugby, basketball. When the attacker will pass the opponent's defense, agility as a support capability to perform high-level skills in fooling the opponent will be very decisive (Sheppard and Young 2006; Young and Willey 2010). Agility can be measured in conventional test such as Shuttle run, 505 Agility, Zig-zag, T test and Illinois (Mackenzie 2008). Currently, there are many studies of agility in the sport of rugby, basketball, soccer, netball, but agility measurement using conventional tests is rarely to be developed.

Agility tests with conventional methods are commonly performed using stopwatch and cones. The test is considered to be less accurate because the timing calculation depends on the accuracy of the testers, if repeatedly very possible human error occurs (Y Hachana, H chaabe`ne, M A. Nabli, A Attia, J Moualhi, N Farhat 2013).

Usually a test using a stopwatch requires one person to use the stopwatch. Problems in agility tests make the development of sensor-based agility gauges

important to improve instrument quality with the aim of improving the accuracy of time-taking. Previous research on the development of agility measurements that is performed research that agility is devoted to certain sports, such as agility tests on: rugby, soccer, basketball and netball (Farrow, Young, and Bruce 2005; Serpell, Ford, and Young 2010; Aaron Scanlan , Brendan Humphries 2013; James et al. 2010). This is because every sport has its own agility characteristic. For the development of sensor-based agility measures are still limited such as the development of agile side step test (Kurniawan et al. 2013), but the tool can only test one type of pattern only the side step test. The development of the tools to be developed is to create a series of digital test kits with sensors that can be adjusted in several agility test patterns, such as Shuttle run, 505 Agility, Zig-zag, T test and Illinois. Development will make it easier to test and can be done without any additional people in testing. Another convenience is to minimize the test time, even if only a few seconds from each implementation. Time efficiency can result in faster test results than using a stopwatch and tends to be fixed, independent of the tool holder as it holds the stopwatch.

If the test is executed with a large sample scale, then the calculation of the time just a few seconds can be a minute or even an hour. Instrument development uses sensors that detect structured motion in the form of agility tests. There are four sensors that can be adapted for agility test needs. The timing starts when the foot passes through the sensor beam and ends when it passes through the sensor beam. These potentials and limitations, researchers interested in developing laser agility-based measuring tools.

2 METHOD

This research develops and validates a new product that is a sensor-based agility test. The steps are called the Research and Development (R&D) cycle (R&D). The products are tested and revised to produce products that meet their manufacturing goals with validity and reliability tests (Pauole K, Madole K, Garhammer J, Lacourse M 2000; Fraenkel, Jack R., Norman. Wallen 2012; Walter R. Borg 1989).

2.1 Participants

The sample involved in the validity and reliability test is 50 students of program study Ilmu Keolahragaan Fakultas Pendidikan Olahraga dan Kesehatan, Universitas Pendidikan Indonesia with age range 19-22 years. The reason for choosing the sample is because they have been accustomed to the test, so there is no need to make long explanations to carry out the test.

2.2 Tool's

The developed product consists of 8 Gorilla Pods for sensor insertion, 4 signaling sensors (laser light), 4 signal receptors, 1 meter cable that can be connected and otherwise have 4 meters and 10 meters, and box counter (screen information time, lap, setting button, reset button, marker light, and buzzer). The sensor has a magnet behind it to be affixed to the metal and rests on the Gorilla Pod. The use of Gorilla Pods makes lasers and receptors available almost anywhere. The cable is made by inserting it in a 5 mm silicon hose designed to be connected in 1 meter, 4 meters, and 10 meters. The cable is connected to the connector to be connected with other cables, so the length can be adjusted as needed. The placement of the sensor should be in the order adjusted to the order of running on the agility test. sensor number 1 and number 4 are in the start and finish line.

2.3 Product Design

This product is conceptualized to be used with a variety of agility tests. The laser sensor must have its own backrest and can be placed anywhere to adjust the various forms of agility tests. Cables must be converted into an adjustable cable length to adjust to track the extent of various forms of agility test, as in the figure. 1 use of sensor-based agility meter on the shuttle run test pattern.

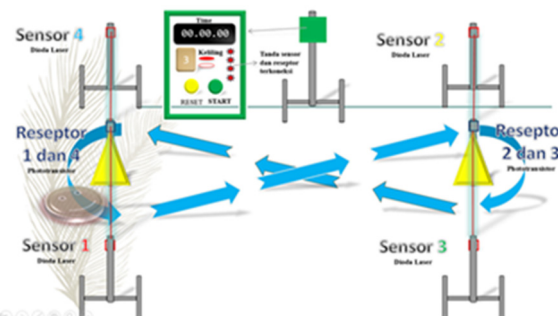

Figure 1: Shuttle run test pattern.

2.4 Operating System

System work tool with the description as follows : 1.) Prepare what agility test will do, 2.) Use cones to mark the track of the agility test track, 3.) Attach the laser and receptor to the Gorilla Pod and place it in the required position, sensor 1 for start and sensor 4 to finish, 4.) Position the box counter outside the track at the desired place, 5.) Set the distance of the cable and adjust the length required, try to keep the cable does not hinder the running of the test, 6.) Connect the box counter with the power source and turn it on, 7.) Set the laser beam to precisely lead to the receptor. Look at the box counter of the connected sensor sign lights, 8.) Add rounds as needed tests, 9.) The test is ready to run, 10.) Each test that has been done will appear the time, then simply press the reset button, then the next test participants can directly perform the test agility. The box and sensor view attached to Gorilla Pod is illustrated in figure 2.

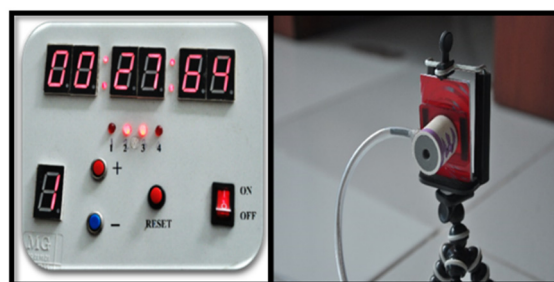

Figure 2: Sensor, box, and cable.

2.5 Validity and Reliability

Validation is an activity process to assess whether the product design, in this case the rational system of work will be more effective than the old or not. Validation of products will be done by comparing test results using sensors with tests using stopwatch. Testing the product by comparing the effectiveness and efficiency of the product from the old work system with the new one (Fraenkel, Jack R., Norman. Wallen 2012; Walter R. Borg 1989). The indicators of the work system assessment of this comparison are the accuracy of the time of assessment and the effectiveness of which test times are better. The product is considered successful when the tool development has more accurate timing accuracy and more efficient testing time. To test the reliability of the measuring instrument agility with sensors that have been developed to do test-retest. Test-retest by way of trying the instrument several times on the respondent then correlated (Fraenkel, Jack R., Norman. Wallen 2012; Walter R. Borg 1989).

3 RESULTS AND DISCUSSION

Many processes have been done until the tool can be tested. The first stage of the electronic circuit is arranged on a printed circuit board (PCB). Which is connected to a sensor attached to a portable poles. Electronic circuit with 12 volt voltage using accumulator. The test results on the shuttle run pattern still has disadvantage, so further improvement needs to be done. Inefficient initial testing because using the start button to initiate the test, this is the same as the uncensored test mechanism. Another disadvantage is the use of portable poles that are too difficult for the sensor to be arranged so that the radiated rays are received right at the receptor. Repair done is to remove the start button, so the test can be started no need to wait for the signal from the tester. Additionally the change replaces the portable pole with an easier gorilla pod in the laser beam setting against the receptor. After experiencing system repairs many times, the tool was deemed to have populated to test the validity and reliability with the following results;

Table 1: Agility test result.

No	Test Name	Average	
		Stopwatch (s)	Sensor's (s)
1	Shuttle Run	15.15	15.51
2	505 Agility	5.19	4.33
3	Zig-zag	5.75	5.54
4	T-Test	11.14	10.85
5	Illinois	19.87	19.77

Looking at the averages in the table. 1 each agility test compared to the test delivery using the stopwatch with the sensor, it is known that the average test using the sensor produces a faster time record. This shows that the test using the sensor is more accurate than the test using a stopwatch.

3.1 Statistical Validity Result

Test validity by comparing agility test results with sensors and without sensors. Figure 3 show average test 1 sensor more quickly than test 1 stopwatch. Statistical analysis was performed using with bivariate correlations with significance 0.05 and Kolmogorov Simonov to test data normality. The results of statistical calculations show the data of normal distribution and the value of pearson correlation 0.784 means there is a high relationship between the test using sensors and without sensors. Then it can be concluded the developed tool can measure what to be measured (Serpell, Ford, and Young 2010; James et al. 2010; Y Hachana, H chaabe `ne, M A. Nabli, A Attia, J Moualhi, N Farhat 2013; Pauole K, Madole K, Garhammer J, Lacourse M 2000).

3.2 Statistical Reliability Result

Test reliability by comparing agility results by using sensors with test re-test. Figure 3 shows the average test of 1 sensor between test 2 sensors only differing 0.1. Statistical analysis was performed using paired sample t-test with significance 0.05 and Kolmogorov Simonov to test data normality. The result of statistical calculation shows normal distribution data and sig value. (2-2tailed) of 0.781 means there is no difference between the initial test and the final test, means to indicate the level to the tool ajegan that can perform its function well repeatedly (Serpell, Ford, and Young 2010; James et al. 2010; Y Hachana, H chaabe `ne, M A. Nabli, A Attia, J Moualhi, N Farhat 2013; Pauole K, Madole K, Garhammer J, Lacourse M 2000).

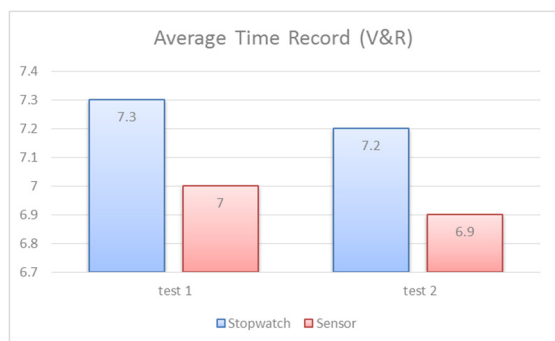

Figure 3: Average time record.

3.3 Discussion

The purpose of this research is to produce agility test based sensor with high accuracy. The results of this research tool mechanism can work in accordance with what will be measured. However, looking at the average shown on the test run test results of sensor-based devices can not outperform conventional tests using stopwatch. It shows the test using the sensor has an average value of 15.51 seconds while the test using the sensor 15.15 seconds. Referring to Velocity = Spatium / time velocity formula, then sensor-based tools should be able to record faster time because speed is inversely proportional to time (Hidayat 2003). Deficiency occurs because when the test run with the shuttle run pattern is the first test that has problems on the use of the start button and portable pole. The repair process by removing the start button so that the test can be done without a signal from the tester and replace the portable pole with a gorilla pod. After improving the results of time records obtained sensor-based tests are able to record time faster than the stopwatch-based.

Although this sensor-based measuring instrument is highly populated which is seen from the results of validity and reliability. This tool still has technical flaws that can disrupt the course of the test. Using cables makes test preparation takes a lot of time to adjust to the agility test pattern. In addition, problems in the sensor system are affected in the hot sun. The solution is in further research to replace the cable system into wireless and replace the infrared sensor with motion sensor with higher sensitivity level.

4 CONCLUSIONS

From the whole range of tests, this test resulted in that time records with the use of sensors, tend to be more accurate than those using the stopwatch. The use of

sensors certainly brings precise timing accuracy on the starting line and finish line. Accuracy calculations also tend to be stable or consistent. In contrast to using a stopwatch that relies on accuracy in using the stopwatch.

Validity test shows that this tool is valid with the result of comparison of conventional performance with developed. Reliability test also shows that this tool has a reliability of the results of the correlation of test 1 and test 2 that shows no difference. Test reliability can also be interpreted that the test results using this sensor will produce stable test results.

The development of this gauge can be used in any light conditions, unless the light is as hot as the sun. Sunlight may interfere with the performance of the receptor, in addition to the use of cables making the measurement preparation time-consuming. Therefore, this prototype can then be improved on the sensor system and wired with using a more efficient and effective wireless system.

REFERENCES

- Aaron Scanlan , Brendan Humphries, Patrick S. Tucker, Vincent Dalbo. 2013. "The Influence of Physical and Cognitive Factors on Reactive Agility Performance in Men Basketball Players." *Journal of Sports Sciences*.
- Farrow, D., W. Young, L. Bruce. 2005. "The Development of a Test of Reactive Agility for Netball: A New Methodology." *Journal of Science and Medicine in Sport*, 40–48.
- Fraenkel, Jack R., Norman. Wallen, Helen. Hyun. 2012. "How to Design and Evaluate Research in Education, 8th Edition." (www.mhhe.com).
- Hidayat, I. 2003. *Biomekanika Pendekatan Sistem Pembelajaran Gerak*. Bandung: PPS Universitas Pendidikan Indonesia.
- James, P, J Alan, S John, James P Veale, Alan J Pearce, John S Carlson. 2010. "Agility Test for Australian Football" 5 (2): 239–48.
- Kurniawan, Faidillah, S Pd Kor, M Or Nidn, M Kes Nidn, and Universitas Negeri Yogyakarta. 2013. *Pengembangan Alat Side Step Test Modification Berbasis Digital Tech*.
- Mackenzie, B. 2008. *101 Tests D'Évaluations*.
- Pauole K, Madole K, Garhammer J, Lacourse M, Rozenek R. 2000. "Reliability and Validity of the T-Test as a Measure of Agility, Leg Power, and Leg Speed in College-Aged Men and Women." *Journal of Strength and Conditioning Research* 14 (4): 443–50.
- Serpell, Benjamin G, Matthew Ford, Warren B. Young. 2010. "The Development of a New Test of Agility for Rugby League." *Journal of Strength and Conditioning Research* 24 (12): 3270–77.
- Sheppard, J. M., W. B. Young. 2006. "Agility Literature Review: Classifications, Training and Testing."

- Journal of Sports Sciences* 24 (9): 919–32.
- Walter R. Borg, Meredith D. Gall. 1989. *Educational Research, An Introduction*.
- Y Hachana, H chaabe`ne, M A. Nabli, A Attia, J Moualhi, N Farhat, M Elloumi. 2013. “Test-Retest Reliability, Criterion-Related Validity, and Minimal Detectable Change Of The Illinois Agility Test In Male Team Sport Athletes.” *Journal of Strength and Conditioning Research* 27: 2752–59.
- Young, Warren B., Ben Willey. 2010. “Analysis of a Reactive Agility Field Test.” *Journal of Science and Medicine in Sport* 13 (3). Sports Medicine Australia: 376–78.

