

Development of a Standing Assistance Walker for a Patient with Low Level of Care

Daisuke Chugo¹, Shohei Kawazoe¹, Sho Yokota², Hiroshi Hashimoto³, Takahiro Katayama⁴,
Yasuhide Mizuta⁴ and Atsushi Kojina⁴

¹*School of Science and Technology, Kwansai Gakuin University, Sanda, Hyogo, Japan*

²*Department of Mechanical Engineering, Toyo University, Kawagoe, Saitama, Japan*

³*Advanced Institute of Industrial Technology, Shinagawa, Tokyo, Japan*

⁴*Service Robot Division, RT.WORKS CO., LTD, Osaka, Japan*

Keywords: Standing Assistance, Active Walker, Patient with Low Level of Care.

Abstract: This paper proposes a novel low cost robotic walker with standing assistance function. Our system focuses on domestic use for elderly people who is low level of care and need nursing in their day-to-day lives. Usually, these patients require a partial standing assistance only when they need it, not a full assistance during standing motion such as a hanging by the lift. The widely and easily use of such assistance in daily life will be successful in ensuring safety and providing an inexpensive manufacturing cost. These two opposed requirements have been realized with our developed robotic walker. Our key ideas are two topics. First is proposal of a mechanical design with minimum and smaller actuators. Proposed system uses a gas spring which helps the up/down actuator and our system assists the patient with wheel actuators on a powered walker for stabilizing its user as well as for lifting up the user. Second is assistance procedure which leads the patient to suitable posture by the force guidance and voice instruction. We investigate what factor enables the patient to stand up safety by preliminary experiment. The performance of our proposed system is verified through experiments using our prototype with elderly and handicapped subjects.

1 INTRODUCTION

Activities such as standing, walking, and sitting may be the most serious and important activities in the day-to-day lives of elderly people as they lack physical strength (Alexander et al., 1999; Hughes et al., 1996). However, assisting elderly individuals in these tasks can be difficult for caregivers and can be a primary source of the lumbago that many of them experience. Thus, developing a caregiving robot capable of assisting the elderly when they stand, walk, and sit is important, and many such devices have been developed and reported in previous studies (Nagai et al., 2003; Funakubo et al., 2001).

In Japan, elderly people requiring assistance in their daily lives are classified into five different care levels (Cabinet Office, Government of Japan, 2016), where care level 1 is minor and care level 5 represents a serious condition such as bedridden life. Elderly people within care level 2 or less are more than 60% and voluntarily body movement in normal daily-life activities is important in order to keep their physical strength, and thereby preventing to become

worse care level (Hirvensalo et al., 2000). They have difficulty in standing, walking or sitting on their own but are otherwise able to perform routine activities if partial assistance only for these motions is provided. This paper calls these situations as low level of care.

In many previous researches, devices that can aid in such activities are developed (Munro et al., 1998), but these are designed for care houses and hospitals because their motivation is reducing the caregivers' burden. On the other hand, the assistive robot for low level of care people should be widely used in their homes. For realizing them, the robot is required to be practical and low cost. The robot should be compact for easy use because standing, walking and sitting motion will be done in narrow space in daily-life activities. Furthermore, the robot should have enough assistive performance and fail-safe design providing an inexpensive manufacturing cost. However, no such robots have yet been developed.

In our previous studies, we developed an assistive robot to continuously aid patients with activities such as standing, walking, and sitting (Chugo et al., 2015; Chugo et al., 2012). The robot

was based on a walker (a popular assistance device for elderly people to use in normal daily life) and had a manipulator with three degrees of freedom (DOF) to assist patients in standing. We designed the robotic walker for realizing enough performance in standing, walking and sitting assistance with safely, but however, we did not consider its manufacturing cost. Its body size was too big for a typical toilet room in Japan, therefore, it was not practical in home usage. Furthermore, this system used many actuators and high-precision sensors, thus, its cost was too expensive and not acceptable for home usage of the patient who is low level of care. For realizing the assistive robot which the many elderly people can use in their daily-life activities, the robot should be practical and low cost, and of course should have enough assistance performance. Therefore, this paper presents a novel standing assistance walker.

For realizing a practical robot, we mainly describe two key topics. First is the proposal of a mechanical design with minimum and smaller actuators. The proposed system can lift the patient's body with a smaller actuator force by combination of a linear actuator and a gas spring. A gas spring generates upper direction force when it lifts up. On the other hand, it stores upper direction force from the patient's body weight when it takes down. Furthermore, the developed system enables standing assistance with only one linear actuator for lifting up the patient's body by using wheel actuators on a powered walker for stabilizing its user.

Second topic is the proposal of an assistance procedure which leads the patient to a suitable posture by force guidance and voice instruction. For realizing safety standing assistance, the subject is required to take a stable posture in standing with the robot. However, it is difficult to guide the motion of the patient because the assistance for the low level of care should follow the patient's motion based on his/her will, should not assist all necessary force for doing a standing motion. Thus, we investigate what factor is useful to guide the patient's motion by preliminary experiment and with this result, this paper proposes a standing assistance procedure with force guidance and voice instruction.

The rest of this study is organized as follows: section 2 explains the configuration of the proposed system, section 3 describes the assistance procedures, section 4 describes a practical experiment with elderly and handicapped people, and section 5 concludes the study.

2 MECHANICAL DESIGN PROPOSAL WITH MINIMUM AND SMALLER ACTUATORS

2.1 Required Condition

2.1.1 Required Assistance Function

As mentioned in the Introduction, elderly people who are low level of care can be considered to be the main audience of our assistance robot. The characteristics of these people are as follows (Cabinet Office, Government of Japan, 2016);

- The patient has dexterity to take a suitable posture if physical load is small.
- The patient can maintain his/her body balance by grasping the handle on the assistive device. In other words, he/she has enough force to grasp it.
- The patient requires force assistance for reducing physical load when he/she lifts up his/her trunk in standing.
- The patient requires assistance for keeping his body balance during standing, walking and sitting assistance.

From these conditions, the assistive robot should have 2DOF minimally, one is up/down direction for lifting the patient's body and the other is forward/backward direction for keeping his/her body stability. We do not consider the right/left direction because we can approximate human standing motion based on the movement on a 2D plane (Nuzik et al., 1986).

2.1.2 Required Condition for Practical Usage

Since the proposed walker is small and mobile, it can be used in any situation in users' homes. In a typical scenario, if a patient would like to go to the toilet room from his/her bed via the corridor, he/she can stand up with the assistance of the walker, walk through the corridor without scratching the wall, enter the bathroom, turn around into the sitting position, and sit down with the device's assistance.

In this scenario, the narrowest room in a Japanese typical home is a toilet room. A typical toilet door with a standard width is 600mm (JIS - Japan Industrial Standard - 1526:1997) and in the toilet room, the width is 800mm minimally. Therefore, for using the robot in daily-life activities, the robot should have the following specifications.

- The robot can pass the entrance with 600mm width.

- The robot can rotate with its patient in the area with 800mm circle.
- The robot can approach a chair, a bed and a toilet enough which enable the sitting patient to use its standing assistance.
- The robot can pass the small steps between the room and corridor floor. Usually, its height is within 20mm in the typical Japanese house.

2.2 Developed Robot

2.2.1 System Overview

Considering these conditions in section 2.1.2, we propose the assistive robot as Fig. 1. Our robot consists of a powered walker and a standing support manipulator, which moves the user in an upward direction so as to be lifted. A standing assistance manipulator has 1 DOF (up/down direction) which is generated by a linear actuator and a gas spring (see section 2.2.2). In standing, our robot assists the patient cooperating with a standing assistance manipulator and wheel actuator. (see section 2.2.3)

Fig. 2 shows a top view of our robot. Its width is 540mm and can pass easily a typical entrance in the patient’s home. Our robot has two actuated wheels in each side. Their axle is same position as the foot center of its patient and he/she can turn easily within the circle which diameter is 800mm.

As Fig. 1(b), our robot uses large casters at front position for increasing the mobile performance on the non-flat ground. Its diameter is 120mm and it can pass easily the 20mm height step. On the other hand, our robot uses small casters at the rear position for preventing the conflict between the caster and objects as legs of the chair which its patient sits on.

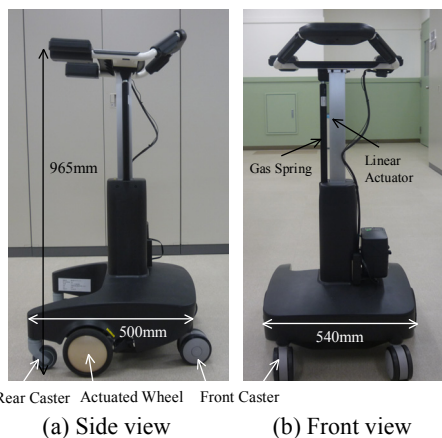

Figure 1: Our developed robot for standing assistance.

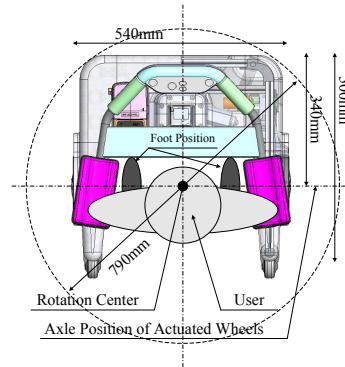

Figure 2: Top view and turning radius of our robot.

2.2.2 Standing Manipulator

A standing manipulator lifts up the patient body directly and its load tends to be large. Generally for this purpose, a high powered actuator is suitable, however, its cost is expensive and there is its malfunction risk. A smaller actuator with high reduction gear is useful choice, however, maximum lifting velocity will be reduced and the robot cannot lift up the patient by a required velocity.

Thus, this study proposes a novel mechanism combing a linear actuator and a gas spring as Fig. 1(b). A gas spring can output force almost constant during its stroke, therefore, it helps the actuator when the standing manipulator lifts the patient. On the other hand, when a gas spring shrinks, it requires down direction force. Usually, in this situation, the standing manipulator assists in sitting, and a gas spring shrinks by the body weight of its patient. Therefore, this device is useful for this purpose and furthermore, a gas spring is widely used and its cost is inexpensive.

Generally, a gas spring generates the force f_l when it extends as (1), and it requires the external force f_u when it shrinks as (2) as Fig. 3. Because of its internal resistance f_r , f_u is larger than f_l as (3).

$$f_l = -\frac{f_{lmax} - f_{lmin}}{y_{stroke}} y + f_{lmax} \quad (1)$$

$$f_u = -\frac{f_{u max} - f_{u min}}{y_{stroke}} y + f_{u max} \quad (2)$$

$$f_u = f_l + f_r \quad (3)$$

where y is the manipulator position and y_{stroke} is its stroke. $f_{i max}$, ($i = l \text{ or } u$) is maximum force which the gas spring can generate and usually, it can

generate at lowest position $y_{\min} \cdot f_{i\min}$, ($i = l$ or u) is its minimum force at highest position y_{\max} .

If the subject applies the maximum load f_{\max} to the robot at y_{lift} when it assists in standing, the following conditions should be fulfilled.

- The total output by the linear actuator and the gas spring is larger than the maximum load as (4) when the robot assists to lift up the patient.
- For shrinking the manipulator without the body weight of the patient, the output of linear actuator is larger than the maximum force which the gas spring requires to shrink as (5).

$$f_l(y_{\text{lift}}) + f_a > f_{\max} \quad (4)$$

$$f_a > f_{u\max} \quad (5)$$

With our proposed mechanism, our robot uses the linear actuator which can generate $f_a = 400\text{N}$ and the gas spring which specifications are shown in Table 1. These selected devices are fulfilled these conditions discussed above.

Fig. 3 is the output force of the gas spring and the typical applied load when the 90kg body weight patient stands up with our robot (Chugo et al., 2016). During the lifting up the patient's body (y is around 50mm to 130mm), the standing manipulator can generate enough upper direction force (more than 650N) with a linear actuator which capacity is 400N.

Using our proposed idea, our robot can use a smaller actuator, which means that its design can be fairly inexpensive. Furthermore, the gas spring prevents the standing manipulator from moving suddenly when the power is down.

Table 1: The specifications of the gas spring.

$f_{u\max} = f_u(y_{\min})$	373N at $y=0\text{mm}$
$f_{u\min} = f_u(y_{\max})$	270N at $y=270\text{mm}$
$f_{l\max} = f_l(y_{\min})$	313N at $y=0\text{mm}$
$f_{l\min} = f_l(y_{\max})$	240N at $y=240\text{N}$
y_{stroke}	270mm

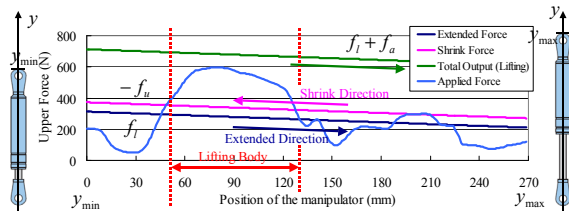

Figure 3: The output force of the gas spring.

2.2.3 Powered Walker

We developed an assistive robot to continuously aid patients with standing, walking, and sitting as Fig. 4 (Chugo et al., 2012). The movement pattern \hat{s} in Fig. 4 refers to a ratio of the standing motion as determined by (6). t_s is the time required to complete the standing operation, and t is the present time.

$$\hat{s} = \frac{t}{t_s} \quad (6)$$

Our developed robot had a standing manipulator with 3DOF to assist patients in standing, because standing motion consists of three phases.

- The first phase, the patient inclines his upper body to the forward direction and moves the center of gravity (COG) to the foot area as Fig. 4(a).
- The second phase, he lifts up his upper body from the chair as Fig. 4(b).
- The last phase, he extends his knee joint completely and ends the standing motion as Fig. 4(c).

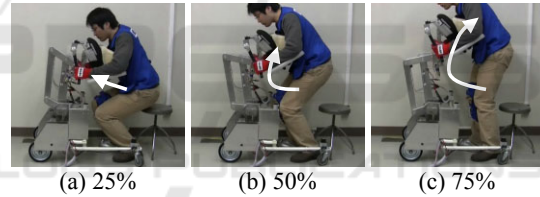

Figure 4: Suitable standing posture guided by our previous standing assistance system (Chugo et al., 2012).

Therefore, the standing assistance requires at least more than 2DOF. For realizing low cost system, our developed robot consists a standing assistance manipulator which has 1 DOF (up/down direction) and a powered walker which has also 1DOF (forward/backward direction). In standing, our robot assists the patient cooperating with a standing assistance manipulator and wheel actuator. Using this design, our robot realizes 2DOF with simple standing manipulator.

By this idea, the powered walker is required to assist not only in walking but also in standing. The standing assistance requires the following function in forward/backward direction (Chugo et al., 2012).

- The first phase, the powered walker should guide the patient's upper body to the inclined posture as Fig. 4(a).

- During standing, the powered walker should keep the body stability in forward/backward direction.

Basically, these conditions require position coordination function and generally, position control is suitable. On the other hand, the robot should apply the force to the patient like force feedback for leading him/her. For this purpose, force control is also suitable.

For realizing these functions, the developed powered walker has an encoder and an ammeter on each wheel. Using these sensors, it can measure its movement distance and the applied force by its patient in forward/backward direction. Each wheel is actuated by the motor driver which can control the wheel cooperating a standing manipulator with position control mode. Using this hardware, we propose wheel control scheme which combines position and damping control mode as (7).

$$\dot{x}_j = \dot{x}_j^{ref} - B(F_x - F_{x0}) - K(x_i - x_i^{ref}) \quad (7)$$

$$\dot{x}_j^{ref} = [x_j^{ref}(0), \dots, x_j^{ref}(\hat{s}), \dots, x_j^{ref}(1)]^T \quad (8)$$

where \dot{x}_i^{ref} is the velocity control reference ($j = \text{left or right}$), which is a function of the movement pattern \hat{s} defined in (8). This reference is calculated from the standing movement recommended by the physical therapists in section 3.1. F_x is the applied force to the forward/backward direction by its user. x_j^{ref} is the position reference and x_j is the actual position. \dot{x}_j is the updated reference that proposed controller inputs to the motor driver during standing assistance. F_{x0} is the coefficient and force that the patient applies to the robot while he/she stands. Using (7), our developed walker has both functions of the position control mode and the damping control mode, and it can fulfilled the required function for standing assistance. B and K are constants that coordinate the ratio between the damping and position controls. We discuss on the parameter setting in section 3.3.2

2.2.4 User Interface

A handle, armrest, and controller are provided on the top of the walker, as shown in Fig. 5(a). There are force sensors inside the armrests which measure the applied force to the vertical direction, and touch sensors on the handles. When the patient wants to move, he/she has to put his/her arm on the armrest and grips the handles. Using the touch sensors and the force sensors, our robot judges whether the

patient is ready to stand; if it judges him/her to be ready, our device guides the patient to push a gripping switch using a voice instruction (These voice instructions will be explained in the section 3.3.).

A gripping switch is provided on each handle, as shown in Fig. 5(b). This switch has two input steps that can be changed by the strength used for the grip. Usually, in emergency situations, elderly people tend to release the control switch or push it strongly because of the fear of falling (E. Maki et.al., 1991). Therefore, we use the two-step switch in such conditions, as shown in Fig. 5(b), and our robot provides assistance for standing only in the case of the first step, whereas in the case of the second step, our robot regards the user as being in an emergency situation.

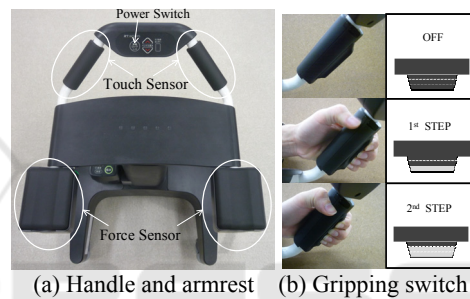

Figure 5: Its user interface.

3 ASSISTANCE PROCEDURES

For realizing standing safety, the patient should take a suitable posture during standing. Our main audience is the low level of care patients, therefore, they has dexterity to take suitable posture if suitable guidance is provided. Therefore, we propose the guidance scheme which leads the patient to take an inclined posture using force guidance and voice instruction.

3.1 Motion Recommended by Nursing Specialists

In a previous study, different types of standing-up movements were proposed. Kamiya (Kamiya, 2005) proposed a standing-up movement that utilizes the remaining physical strength of a patient, as determined by their nursing specialist. Fig. 6(a) shows an example of this movement proposed by Kamiya.

In our previous study, we analyzed this standing movement, and we found that Kamiya's proposal

was effective in enabling the patients to stand up with minimum load (Chugo et al., 2012). We assumed that the standing motion is symmetrical and discussed the motion as a movement of the linkages model on a two-dimensional (2D) plane as shown in Fig. 6(b) (Nuzik et al., 1986). We measured the angular values among the linkages as these reflected the relationship between different parts of a body.

From the measured results, we can verify that to achieve the motion proposed by Kamiya, a patient's trunk needs to incline in the forward direction while getting up from a chair, as shown in Fig. 7(a). In this figure, the Y-axis shows the angular values of the pelvis and trunk, knee, and ankle, whereas the X-axis shows a movement pattern (Nuzik et al., 1986), which is the ratio of the standing-up motion, as shown by (6). Fig. 7(b) shows the position of a patient's center of gravity (COG), which indicates the body balance of the patient during the standing motion.

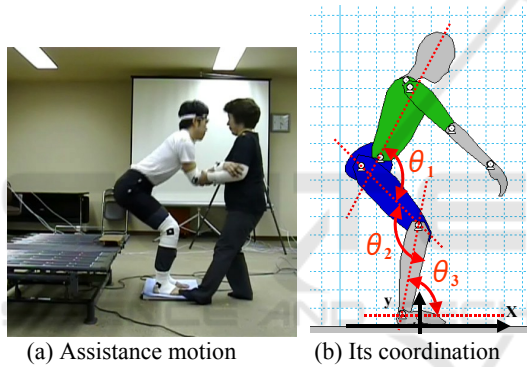
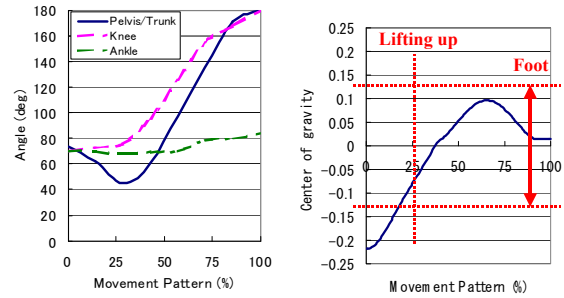

Figure 6: Standing-up motion as described by Kamiya. θ_1 shows the angular value of the pelvis and the trunk. θ_2 and θ_3 show the angular values of the knee and the ankle, respectively (Chugo et al., 2012).

To realize this motion, we derived the control reference of our assistance system kinematically. We assume the human model as Fig. 6(b) moves each joint according to the measured values as Fig. 6(a). For assisting this human model movement, we can derive the position which the standing manipulator should assist in standing (Chugo et al., 2012). In this study, our robot uses them as the control reference. For this derivation, the parameters were chosen from the standard data of the body of an adult male (Okada et al., 1996), as shown in Table 2.

Fig. 8 shows the positions of the handle in standing. In Fig. 8, the Y-axis shows the up/down position (by the standing manipulator) or the forward/backward position (by a moving function on a powered walker) of the handle, and the X-axis



(a) Angular values of each joint (b) Its coordination

Figure 7: Analysis of the standing-up motion proposed by Kamiya. The size of the foot of the human model was 0.26m, and the foot area is shown by the red arrows in (b). At a 25% movement pattern, the subject lifts up his/her body.

shows the movement pattern. The coordination of Fig. 8 is defined as in Fig. 6(b). Using these tracks as the position control reference, our robot can realize the standing motion proposed by the nursing specialist.

Table 2: Human Parameters.

Linkage Name	Length [m]	Width [m]
Head	0.28	0.21
Trunk	0.48	0.23
Hip	0.23	0.23
Humerus	0.39	0.12
Arm	0.35	0.08
Hand	0.2	0.07
Femur	0.61	0.17
Leg	0.56	0.16
Foot	0.26	0.11

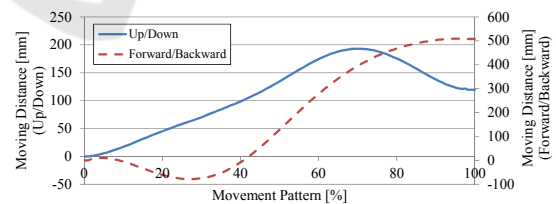

Figure 8: The reference in standing.

3.2 Force Guidance in Standing

For guiding the patient to take the inclined posture when the robot starts to assist in standing, our robot moves to the forward direction according to the reference as Fig. 8 and this movement tells the patient that he/she should incline his/her upper body to the forward direction. In our previous work, we found the suitable force applying could tell its user

how the robot would guide him/her (Chugo et al., 2015). Thus, in section 2.2.3, we propose the wheel control scheme which has both position control performance and force control performance.

Proposed controller changes both performance by two coefficients, B and K in (7). B coordinates force control performance ratio and K coordinates position control performance ratio. In this paper, we investigate the suitable ratio between two parameters for guiding the patient to the suitable posture by the preliminary experiment.

3.2.1 Preliminary Experimental Setup

In this experiment, subjects try three test cases as Table 3. Subjects are 23 young students whose age are 21 to 24. All subjects use our robot for the first time and we request them to stand simply according to the robot’s movement. After this experiment, we ask them two questions. First question is “Did you notice the robot tried to make you do what kind of movement at the beginning?” Second question is “How feel did you during standing assistance by our robot?” Seven subjects try the standing assistance provided by case1, another eight subjects are case2 and another eight subjects are case3.

Table 3: Test cases in the preliminary experiment.

	B	K
Case 1: Force mode	0.8	0.2
Case 2: Moderate Mode	0.5	0.5
Case 3: Position Mode	0.2	0.8

3.2.2 Preliminary Experimental Results

Table 4 shows the experimental results. By standing assistance by our robot, in case2, almost all subjects can stand according to the reference. On the other hand, in case1, in some trials, the subject fails to stand. Fig. 9(a) shows the typical failure. In this failure, the subject noticed the robot tried to guide to the forward direction by its force. However, the subject could not find the suitable position because the robot did not show the reference position clearly because of the low position control ratio, and as the result, the subject failed to stand as Fig.9 (a). In case3, the subject also failed to stand in some trials as Fig. 9(b). In this failure, the subject did not notice the robot guided to the forward direction because the guidance force was weak. As the result, the subject did not move the position of COG to the forward direction and his body balance was unsuitable.

From the questionnaire results as Table 4, in case1 and 2, almost all subjects noticed the robot guidance to the forward direction, thus, force control approach seems to be effective for this purpose. However, too strong force causes the subject felt a fear and should be avoided by the results in Table 4. In case3, some subjects did not notice the robot guidance to the forward direction and it causes the standing assistance was uncomfortable. This means to provide the effective standing assistance, the powered walker should have both position control function and force control function.

From these results, our powered walker uses the parameter settings as case2 which activates both position and force control function in standing.

Table 4: Experimental Results and Questionnaire Answers.

	Case1	Case2	Case3
Success in standing by our robot	5/7 71%	7/8 88%	4/8 50%
Question 1: The inclined body posture	7/7 100%	7/8 88%	5/8 63%
Question 2: Fear or uncomfortable	3/7 43%	0/8 0%	3/8 38%

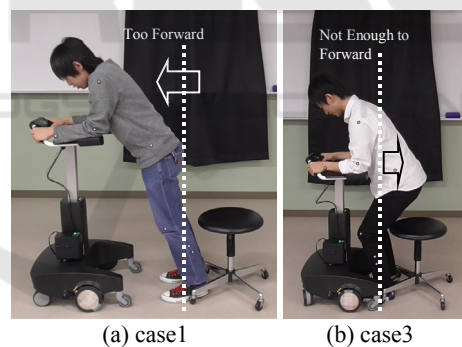

Figure 9: Typical failure of standing.

3.3 Assistance Procedure with Voice Instruction

For safety standing, our robot guides the patient by voice instruction. At the beginning in standing, the patient’s upper body needs to incline in the forward direction. From the opinions of the physical therapists, these information are required for the patient to take this posture.

- The patient should incline his/her upper body to the forward direction.
- The patient should face to the bottom of the forward direction.

- The foot should move to the back position, should not take the posture which throws out his/her leg.

Considering with them, we propose the assistance sequence with voice instruction as Fig. 10. Table 5 shows the voice instructions provided in Japanese by the device as well as their English translations.

When a user turns on the power of the walker, an announcement (Message A) is spoken. After that, the walker remains in a waiting state until both touch sensors and force sensors are turned on. The user has to touch the gripping switches and put their weight onto the armrests, because the device must first check whether the user is holding the walker properly to decide whether it is safe to provide the assistance.

If these sensors respond, a voice announcement (Message B) tells the user to stand ready to move. After this, when the user grips the switches on the handle as the first-step input shown in Fig. 5, the device initiates its standing assistance. The user has to continue holding the switches on the first-step input, as elderly people generally tend to release their grasp or become stiff if they feel scared (Omori et al., 2001). Thus, if the user releases its grip, the second-step input or no input, the system stops the assistance. When no further assistance is required, the actuators stop moving and a voice announcement encourages the user to walk.

During the standing motion, our device leads user to a suitable standing posture using the two DOF (i.e., the up/down direction and forward/backward direction).

After the user stands up, they can use the device as a powered walker (Hirata et al., 2007).

Table 5: Voice Announcements.

No	Voice Message	Its Objective
A	I'll do my best to support you.	Saying hello to the user.
B	Move your feet back and bend your body to forward. Then, grip the switches on the handle.	Telling the user to ready his/her posture to stand up soon.
C	Let's stand up together.	Signal of start of the standing up motion.
D	Have done. Let's walk carefully with me.	Signal of end of the standing up motion and encouraging the user to walk.

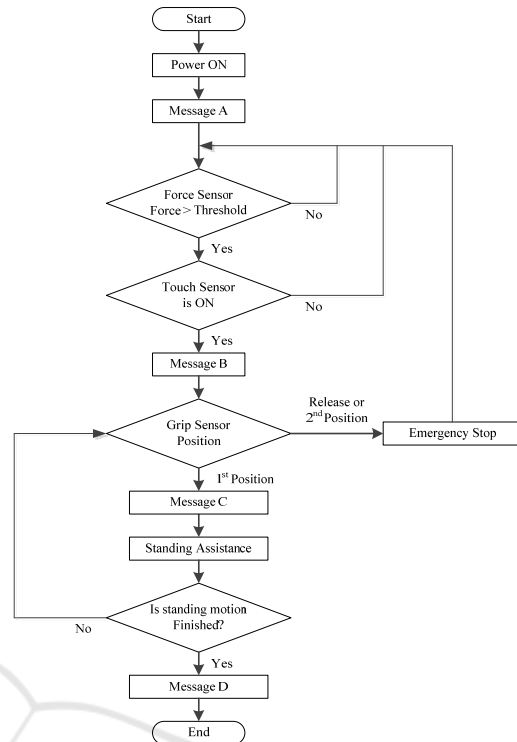

Figure 10: Standing assistance process flow.

4 ASSISTANCE PROCEDURES

To confirm the efficiency of the proposed assistive robot, we conducted a practical experiment.

4.1 Experimental Setup

To verify its effectiveness, we used three test cases. In case1, our proposed system assisted a standing motion with all proposed technique. In case2, our system assisted a standing motion without proposed force guidance function (only velocity control, $B=K=0$ in (7)), because it simulates standing assistive devices traditionally provided by many manufacturers (Funakubo et al., 2001). In case3, our system assisted a standing motion with only the standing manipulator, and it simulates the automatic movable handrail equipped the bedside which is widely used in care houses and hospitals.

We used four subjects. All subjects were elderly or handicapped people with disabilities and required standing assistance in their daily activities. All the details about these four subjects are provided in Table 6.

During this experiment, we measured the body movement by the motion capture system and the applied force to the up/down and the forward/backward direction by equipped sensors on our robot. Using measured values, we can estimate the traction output of waist, knee and ankle joint as an index of the physical load of the patient. For detail estimation scheme, please refer our previous research (Chugo et al., 2015).

All the experiments were performed by nursing specialists and under the ethical rules and technical safety measures provided by the Yokohama Rehabilitation Center, Shin-Yokohama, Kanagawa, Japan.

Table 6: Subjects.

No	Weight /Height	Age	Care Level	Remarks
A	60kg /170cm	60	Level2	Peripheral neuropathy, Paraplegia
B	78kg /178cm	52	Level2	Ataxic both sides hemiplegia
C	68kg /152cm	68	Level2	Limb paralysis, Parkinson's disease
D	58kg /178cm	34	Level1	Hypoxic encephalopathy, Limbs and trunk ataxia

4.2 Experimental Results

Figs. 11–14 are visual descriptions of the experiments. Fig. 11 describes a series of standing scenes of subject A, whereas Fig. 12 is about subject B, Fig. 13 is about subject C, and Fig. 14 is about subject D. These pictures show that all the subjects were able to stand up without the occurrence of any accidents.

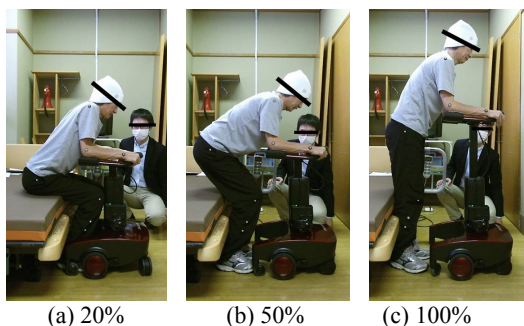

Figure 11: Subject A (Case1).

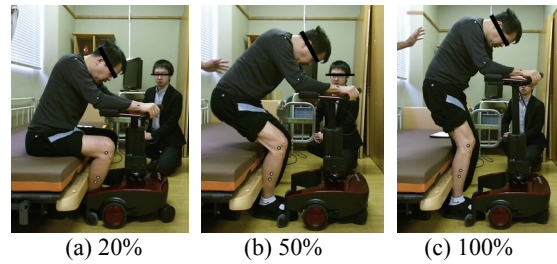

Figure 12: Subject B (Case1).

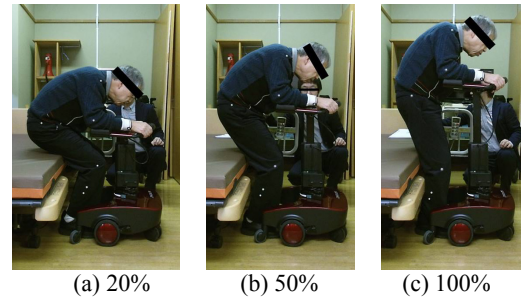

Figure 13: Subject C (Case1).

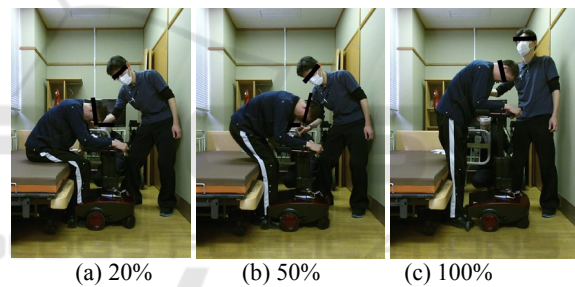

Figure 14: Subject D (Case1). For safety reason, a therapist stays near the subject during this experiment.

All subjects evaluated our assistance robot using a questionnaire after the experiment as Table 7. The subjects A to C evaluated case1 is better and on the basis of their responses, we were able to tell that leading to the suitable posture was important during the standing assistance. Subject D, meanwhile, found case 3 to be better because he had limbs and trunk ataxia caused by hypoxic encephalopathy and leaned completely against our assistance system.

Fig. 15 shows the estimated torque on the ankle, knee, and waist of subject A on each case. Furthermore, we show the estimated torque when he stands up only by his own physical strength using a handrail equipped on the bedside. In Fig.15(a) without assistance case, maximum traction is about 1.0 Nm/kg on a knee joint. In Fig.15(b), traction is within 0.5Nm/kg in case1, in Fig.15(c), traction is within 0.8 Nm/kg in case2 and in Fig.15(d), traction is within 0.6 Nm/kg in case3. From previous

research, maximum traction should be within 0.5 Nm/kg for safety standing motion by own physical strength of elderly people (Fisher et al., 1990). Case1 has a best assistance performance and this result indicates the suitable posture during standing motion is maintained using our ideas. Furthermore, Fig. 16 shows maximum traction output of a knee joint when the subjects A to D lift up his body. According to these results, the subjects were supported with the lowest burden in all of the three cases, and case1 has best assistance performance in standing.

Fig. 17 shows the position of the COG on the forward/backward direction of subject A. These results were calculated according to the linkage model and the assumptions outlined in section 3.1. As shown in Fig. 17, the COG movement in case 1 was closest to the reference. In case 2, the COG was over 20 cm, which means that the traditional controller led to the users leaning too far forward. In contrast, in case 3, the COG was less than 10 cm, which implies that the users did not move forward enough to bend their body or may be led in danger. Moreover, Fig.18 shows the COG of subject A to D at 60 % movement pattern. At this time, subjects incline their trunk and lift up it to upper position. According to this result, in all subjects, the COG fit the designed reference and we can evaluate the body balance is suitable in case1. In case2, the COG is too far and in case 3, the COG is too close. These unsuitable COG lead a risk of falling down and in the questionnaire results as Table 6, some subjects feels it. On subject D, COG tends to be large value because this subject leaned completely against our assistance system.

According to these results, our robot succeeds to assist the subjects with the lowest burden and suitable body balance during standing motion with proposed robot system (case1). Moreover case3 (position fix version) may be effective when the target user completely does not have dexterity to maintain a body balance.

Table 7: Questionnaire results.

No	Case1	Case2	Case3
A	Good	Body balance is bad.	Body balance is bad.
B	Good	Fear of falling.	Body balance is bad.
C	Good	Acceptable, case 1 is better.	Body balance is bad.
D	Acceptable, case3 is better.	Fear of falling.	Good

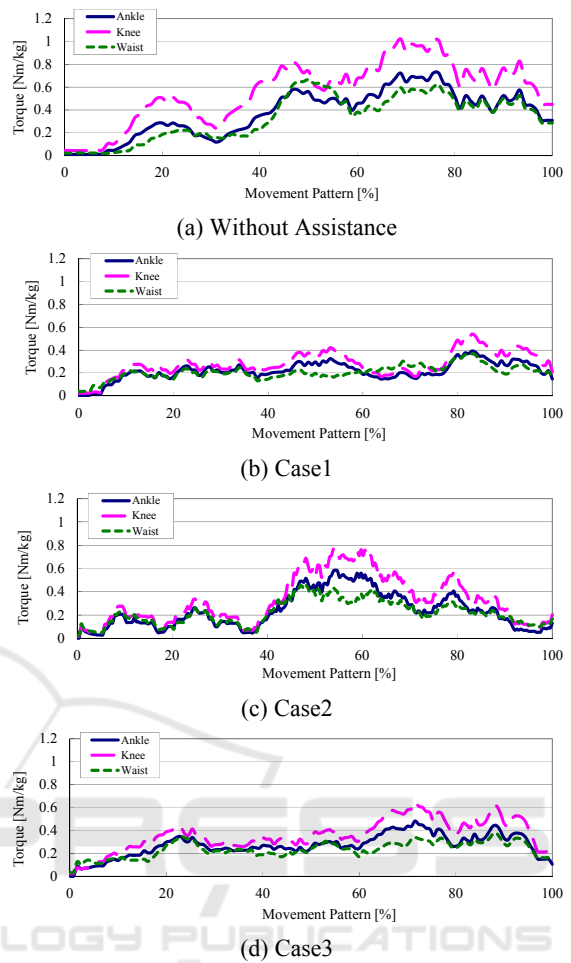

Figure 15: Traction output of each joint (Subject A) during standing motion.

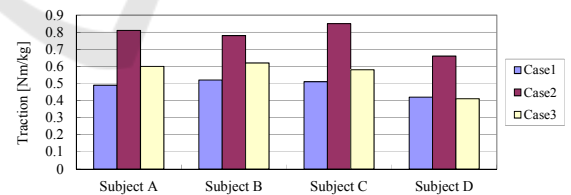

Figure 16: The maximum traction output in each subject.

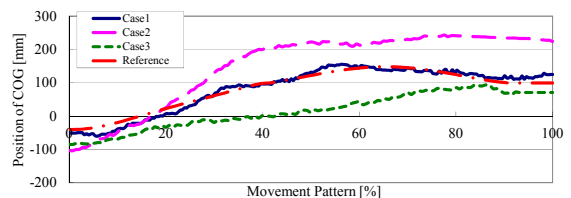

Figure 17: The position of COG (Subject A) during standing motion.

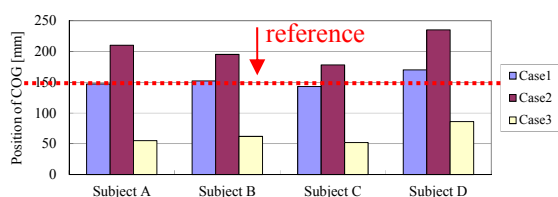

Figure 18: The position of COG at 60[%] movement pattern in each subject.

5 CONCLUSIONS

This paper proposes a novel low cost robotic walker with standing assistance. Proposed robot focuses on domestic use for elderly people who is low level of care and need nursing in their day-to-day lives. For the robot to be used widely and easily in daily life, it is important to ensure safety and provide an inexpensive manufacturing cost.

For realizing two opposed requirements, this paper proposes the novel mechanism design and the assistance procedure which leads the patient safety and stability. Proposed mechanical design uses a gas spring which helps the lifting linear actuator with minimum cost and developed robot assists the patient with wheel actuators on a powered walker for stabilizing its user as well as for lifting up the user. Furthermore, proposed assistance procedure leads the patient to suitable posture by the force guidance and voice instruction. For realizing it, we investigate what factor is useful for leading the patient by preliminary experiment.

The developed prototype has enough assistance performance through experiments with elderly and handicapped subjects. Thus, our study succeeds to develop a safety and low cost robot which has enough standing assistance performance for the patient who is low level of care.

For our future work, we plan to develop the wheel control algorithm for walking assistance.

ACKNOWLEDGEMENTS

The authors would like to thank T. Kumeda, a physical therapist, and all the staff members at Yokohama Rehabilitation Center for providing technical assistance in the experiments.

This work is supported in part by the Matching Planner Program (MP28116808328) from Japan Science and Technology Agency (JST), Grant-in-Aid for Scientific Research C (16K01580) from

Japan Society for the Promotion of Science (JSPS) and the Robotic Devices for Nursing Care Project from Japan Agency for Medical Research and Development, AMED.

REFERENCES

- N. B. Alexander, A. B. Schultz and D. N. Warwick, 1991. Rising From a Chair: Effects of Age and Functional Ability on Performance Biomechanics. In *J. of Geometry: MEDICAL SCIENCES*, Vol.46, No.3, M91-98.
- M. A. Hughes, M. L. Schenkman, 1996. Chair rise strategy in the functionally impaired elderly. In *J. of Rehabilitation Research and Development*, Vol.33, No.4, pp.409-412.
- Cabinet Office, Government of Japan, 2016. *KOUREISHA HAKUSHO (The whitepaper on the aged society)*, ISBN: 4865790519, pp.25, (in Japanese).
- K. Nagai, I. Nakanishi and H. Hanabusa, 2003. Assistance of self-transfer of patients using a power-assisting device. In *Proc. of the IEEE Int. Conf. on Robotics and Automation*, pp.4008-4015.
- A. Funakubo, H. Tanishiro and Y. Fukui, 2001. Power Assist System for Transfer Aid. In *J. of the Society of Instrument and Control Engineers*, Vol.40, No.5, pp.391-395.
- M. Hirvensalo, T. Rantanen and E. Heikkinen, 2000. Mobility difficulties and physical activity as predictors of morality and loss of independence in the community-living older population. In *J. of the American Geriatric Society*, Vol.48, pp.493-498.
- B. J. Munro, J. R. Steele, G. M. Bashford and M. Ryan, 1998. A kinematic and kinetic analysis of the sit-to stand transfer using an ejector chair: implications for elderly rheumatoid arthritic patients. In *J. of Biomechanics*, pp.263-271.
- D. Chugo, Y. Morita, Y. Sakaida, S. Yokota, H. Kobayashi, H. Hashimoto and K. Takase, 2012. Standing Assistance Control using a Physical Strength of a Patient with Load Estimation. In *Proc. of 21st IEEE Int. Symp. on Robot and Human Interactive Communication*, pp.234-239.
- D. Chugo, T. Yamada, S. Muramatsu, S. Yokota, and H. Hashimoto, 2015. Assistive Robot for Standing with Physical Activity Estimation based on Muscle Arrangements of Human Legs. In *Proc. of 12th Int. Conf. on Informatics in Control, Automation and Robotics*, pp.35-43.
- E. Maki, P. J. Holliday and A. K. Topper, 1991. Fear of falling and postural performance in the elderly. In *J. of Gerontology*, Vol.46, No.4, pp. 123-131.
- K. Kamiya, 2005. Development and evaluation of life support technology in nursing. In *Proc. of 7th RACE Symp., Research into Intelligent Artifacts for the Generalization of Engineering*, pp.116-121.
- D. Chugo, E. Okada, K. Kawabata, H. Kaetsu, H. Asama, N. Miyake, and K. Kosuge, 2006. Force Assistance

- Control for Standing-Up Motion. In *Proc. of the First IEEE/RAS-EMBS Int. Conf. on Biomedical Robotics and Biomechatronics*, DOI: 10.1109/BIOROB.2006.1639073.
- S. Nuzik, R. Lamb, A. Vansant and S. Hirt, 1986. Sit-to-Stand Movement Pattern, A kinematic Study. In *Physical Therapy*, Vol.66, No.11, pp.1708-1713.
- H. Okada, M. Ae, N. Fujii and Y. Morioka, 1996. Body Segment Inertia Properties of Japanese Elderly. In *Biomechanisms*, No.13, pp.125-139.
- D. Chugo, S. Aburatani, T. Masushige, S. Muramatsu, S. Yokota and H. Hashimoto, 2015. A Hand Movement which shows the Intention of a Robotic Guide for Safe Walking, In *Proc. of the 24th Int. Symp. on Industrial Electronics*, pp.940-945.
- Y. Hirata, A. Hara, and K. Kosuge, 2007. Motion Control of Passive Intelligent Walker Using Servo Brakes. In *IEEE Trans. on Robotics*, pp.981-990.
- K. Omori, Y. Yamazaki, H. Yokoyama, U. Aoki, M. Kasahara, K. Hiraki, 2001. The relationship between strength in the lower extremity and the ability to stand up from a chair in elderly inpatients. In *Sogo Rehabilitation*. Vol.30, No.2, pp.167-171.
- N. M. Fisher, D. R. Pendergast and E. C. Calkins, 1990. Maximal Isometric Torque of Knee Extension as a Function of Muscle Length in Subjects of Advancing Age. In *Arch. Phys. Med. Rehabil.*, Vol.71, No.10, pp.729-734.

