

Towards Adapting Scientific Workflow Systems to Healthcare Planning

Bruno S. C. M. Vilar, Claudia Bauzer Medeiros and André Santanchè

IC - UNICAMP, 13083-852, Campinas, SP, Brazil

Keywords: Scientific Workflows, Task Network Models and Nursing.

Abstract: Healthcare and research environments have common characteristics and needs, such as managing people and resources, planning and conducting distributed activities, event-sensitive and monitoring processes. There are several examples in which Workflow Management Systems can aid healthcare management, systematizing, logging and automating activities. In this work we propose a context-driven approach to produce health workflows, which goes beyond an adaptation of workflows tasks to afford health procedures – as proposed in related work – departing from the rationale born from health professionals and materialized in CIG. This paper presents our proposal to support nursing processes through customization of workflows tools using as a starting point a comparative study of systems with respect to features required by healthcare professionals.

1 INTRODUCTION

Healthcare facilities involve the management and coordination of healthcare providers, patients, and resources. There is a need for automated ways to monitor and integrate the flow of exams, nursing procedures and resources.

A common approach adopted to model healthcare processes are Computer-Interpretable Guidelines (CIGs), which implement guidelines in active computer-based decision support systems, able to monitor actions and observations of care providers and to provide guideline-based advice at the point of care (de Clercq and Kaiser, 2008). CIG can be modelled as Task-network Model (TNM), which “decomposes guidelines into networks of tasks unfolding over time” (Ye et al., 2009). A TNM can be seen as a hierarchical directed graph that specifies a flow of activities. Its enactment is often supported by artificial intelligence planning environments, in which a TNM is specified using some adaptation of a goal-based planning language.

Our key argument in this paper is that CIG systems, born in the healthcare context, embed the usual rationale applied in this context, tailored to the dynamic healthcare environment. Workflows, on the other hand, are robust tools, broadly tested and refined by the community for many domains. They are being increasingly adopted in hospitals – e.g., (Riaño et al., 2012) – to support task automation, but are based on standard (business) workflow environments.

Healthcare activities involve a dynamic scenario, in which professionals have to constantly interact with the tools, to register patient information, intervention plans, and desired outcomes, creating the need for flexible workflow management.

As Panzarasa and Stefanelli (Panzarasa and Stefanelli, 2006) highlight, “a critical challenge for any Workflow Management Systems (WfMS), in a real clinical setting, is its capability to respond effectively when exceptions occur. An exception can be defined as any deviation from the normal flow of activities, and it can arise from changes in resource availability, task requirements or task priority, and anomalous, but expected, effects of delivered care.”

In fact, the generic modeling approach adopted by workflows, contrasts with the domain-specific formalisms (e.g., TNM) applied to model clinical practice guidelines. These formalisms are derived from the practical clinical activities and embed their rationale and approach to plan and manage activities.

There are research on adding flexibility to WfMS in a healthcare scenario, such as (Dang et al., 2008), (Mikolajczak and Shenoy, 2010), and (Schick et al., 2012). There are, however, additional requirements to be fulfilled so that a WfMS can provide an adequate environment for practical clinic usage, such as preserve the systematization and work organization of clinicians, provide the traceability of actions, allow remote and collaborative work, among others.

Our solution to overcome these problems is based on two aspects: first, to adopt scientific workflow

systems¹; second, to extend these systems with facilities for dynamic self-adaptation based on context. Our context-driven approach is a glue that enables to “think” workflows using a healthcare perspective.

Scientific workflow systems are normally adopted in research environments, to manage research activities, specification and execution of experiments. Given their event-driven characteristics, openness, flexibility, support to distributed collaborative work, and ability to handle exceptions, they are more suitable to health environments than business workflows.

This paper justifies this claim through analysis on the requirements of WfMS, created for scientific and business contexts, comparing their features with CIGs, applied to the healthcare domain. Our second ingredient – context-driven self-adaptation – is derived from the approach of planning and monitoring healthcare activities, as observed in TNM specifications.

The contributions of this paper are: (i) an outline of the architecture proposed with a case study (Section 4); (ii) a detailed analysis of the factors that led us this proposal, and comparative tables (Sections 2 and 3).

2 RELATED WORK

2.1 Context

One of the aspects to be covered in this work is adaptation of workflows to a context. Defining the term “context” in an accurate or complete way is not a simple task: in the literature, it varies according to the perspective of who uses the term, and where it is used. (Millard et al., 2004) say that “it is very difficult to take into consideration all the contextual factors in one information retrieval system, so that researchers often define the context as certain factors (location for example)”.

(Dey, 2000) presents a generic definition of context, from a Computing perspective: “any information that can be used to characterize the situation of an entity. An entity is a person, place, or object that is considered relevant to the interaction between a user and an application, including the user and application themselves”. (Strang et al., 2003) define the term as: “the set of all information characterizing the entities relevant for a specific task in their relevant aspects”.

The definitions of (Bolchini et al., 2007), (Dey, 2000) and (Strang et al., 2003) are generic with re-

¹As opposed to the business workflow systems adopted in hospitals.

spect to the application. However, researchers more commonly require tailoring a concept to their needs, e.g., as in (Asfari et al., 2010). For them, “context describes the user current task, its changes over time and its states, i.e. we take into account the task which the user is undertaking when the information retrieval process occurs”. (Turner, 1999), concerned with Intelligent Agents, defines context as “a distinguished (e.g., named) collection of possible world features that has predictive worth to the agent”. To (Bandara et al., 2009), it is “any static or dynamic client-, provider- or service-related information, which enables or enhances efficient communications among clients, providers and services”.

The variation of the use of “context” in different fields and purposes results in diverse denominations. Table 1 summarizes our survey of the usages of the term. The table shows for each paper the application area, the domain of use and the representation of “context”. This study also showed that diverse kinds of information can be used to specify “context”, such as: those that identify a user’s characteristics and preferences; or the location of an event and information about it, such as history, climatic conditions, legislation, service characteristics, domain, platform and others. This information is collected in different ways: sensors, logs of users’ actions in systems, forms and others.

In spite of a wide space of variables to identify a context – eg. domain, service, location, identity, and device –, some can be highlighted. To (Dey, 2000), location, identity, time, and activity are the most important context variables to characterize the situation of an entity. According to the author, these kinds of contexts not only can answer questions such as “Who”, “What”, “When” and “Where”, but also they can act as indexes to other contextual information sources. For instance, in all mobility and location-based studies, the most important variables are space (coordinates) and time.

2.2 Scientific Workflows

A workflow is the sequence of steps that are necessary to achieve a specific goal (Barthelmeß, 1996). It allows to systematize a task in activities that, from their respective input resources, generate a certain result. Each activity can be composite or atomic. Workflows can be designed from an abstract specification that is refined gradually until it reaches an execution level – a concrete workflow (Medeiros et al., 2005). An abstract specification helps to understand how workflow tasks are carried out, identify problematic spots (e.g., bottlenecks), and analyze changes that can be carried

Table 1: Characteristics of work using the notion of context.

Work	Computing-related Aspects	Application Domain	Context Representation in a Computer
(Dey, 2000)	Context-Aware Computing	Generic	-
(Millard et al., 2004)	Context-Aware Environments	Pervasive Computing	Multiple Ontologies (OWL)
(Bolchini et al., 2007)	Evaluation Framework - Context Models	Generic	Generic: analyze and suggest models
(Bandara et al., 2009)	Web Services Composition	Business	Ontology (OWL - light)
(Kholadi and Doan, 2010)	Information Retrieval	Generic	Relational DB
(Asfari et al., 2010)	Information Retrieval	Generic	Tasks represented as UML State Diagram. Terms associated to ontologies (WordNET e ODP)
(Carmagnola et al., 2005)	Adaptive Hypermedia	Generic/Validation: Tourism	Multi-ontology matrix and SWRL rules
(Lundberg, 2007) and (Lundberg and Rune, 2009)	Distributed Environment Information Sharing	Emergency Service Centres	Inference rules mapped on Workflows Simulates: state and consequence
(Bardram and Hansen, 2010)	Computer-Supported Cooperative Work	Hospital Clinicians	Not specified
(Strang et al., 2003)	Middleware	Generic	Ontology (represented in: OWL, DAML+OIL and F-Logic)
(Cho et al., 2010)	Workflows	Agriculture	RDF: restrictions. uWLD: context aware workflows language.
(Turner, 1999)	Intelligent Agents	Medical Diagnosis	C-Schemas ("frame-like")

out in designing the workflow. Executable (or concrete) activities are those associated with some tool or service that processes or aids the obtention of results that serve as input to other activities.

Workflow management, coordination of processes and other functionalities are the responsibility of WfMSs. These systems orchestrate algorithms and computational processes, combining parallel and distributed processing, databases, artificial intelligence, among others, building a repository for experimentation through simulation (Deelman et al., 2009).

WfMSs allow processes to be organized in different ways to meet requirements and processing needs. The main characteristic of a WfMS is process automation, involving the combination of activities performed by people and computers (Hollingsworth and Others, 1993). The role of these systems, however, is not limited only to the automation, but also allows to obtain process information in different levels of detail, besides systematically capturing provenance information of produced data (Scheidegger et al., 2008).

In this paper, scientific workflows are adapted to healthcare. A scientific workflow can represent the process chaining that transforms data aiming at an experimentation by simulation (Ogasawara et al., 2008). These systems "enable researchers to collaboratively design, manage, and obtain results that involve hundreds of thousands of steps, access terabytes of data, and generate similar amounts of intermediate and fi-

nal data products" (Deelman and Chervenak, 2008). Thus, scientists can focus on their research and not on computation management (Deelman et al., 2009).

2.3 Computer-interpretable Guidelines

"Clinical guidelines can be viewed as generic skeletal-plan schemata that represent clinical procedural knowledge and that are instantiated and refined dynamically by care providers over significant time periods" (Shahar et al., 1998). There are also specialized versions of the guidelines, e.g., Nursing Clinical Guidelines, which provide evidence-based instructions/recommendations about how to handle specific patient care issues (Din et al., 2010).

Even though the guidelines represent clinicians' background about suggested ways to deal with health issues, (Fox et al., 2009) highlight that the clinicians' judgment may conflict with the general guidelines, so the treatment may differ from the one originally stated. This may occur because the guidelines are generic, and thus may not consider new knowledge about the treatment, or patient allergy to the medicine, etc.

To automate the process of guideline application, as well as avoid errors and improve the process, there is the study and development of Computer-Interpretable Guidelines (CIGs). There are several rich studies to provide support for clinicians, such as

Clinical Decision Support Systems (El-Fakdi et al., 2012), Care Flow (Mikolajczak and Shenoy, 2010), Task Network Model (Ye et al., 2009), Clinical Pathway Management System (Ye et al., 2009), and Healthcare Information Management System (Dang et al., 2008). To be effective, “these tools need to be simple to use, easily available, and work with different information systems in changing environments” (Leong et al., 2007). For those characteristics, there is a need to: i) Preserve methodology and systematization already applied by clinicians; ii) Provide flexibility to adapt the guideline instance to the situation; iii) Dispose of open and extensible environment to add resources and better suit the solution to the problem.

Our work tries to comply with those requirements combining features from WfMS and CIG systems. Section 3 analyses characteristics from both systems.

3 COMPARING WFMS AND CIG SYSTEMS

Ideally, automated systems to support healthcare activities must comply with a variety of software requirements. They must be flexible, extensible by plug-ins, support different kinds of activities (services, languages, etc.), allow annotation of tasks, register provenance, provide access by a remote client, and support changes according to context variables. Also, they must maintain the nature of work of clinicians, be flexible to changes, responding to new information about patients. We analyzed different tools designed to automate and monitor activities with respect to these properties, as a necessary step to understand deficiencies and advantages of such tools. We present the results of this study in this section.

We separated the analyzed features in two groups, infrastructure and organization, respectively presented on Tables 2 and 3. On Table 2, features are focused on resources that allow flexibility to extend the tool, including its openness and extensibility by plug-ins, possibility to annotate (describe) basic components, share and reuse resources, schedule activities and provide some level of security. We use ‘+’ to indicate compliance, ‘±’ a partial or limited compliance, and ‘-’ the lack of it. On Table 3 we analyzed the following: the basic component (building block) of the system, how it can be associated to other components, and which resources can be used to define a component. The table also contains a description of flexibility to change the flow of execution and which contextual information is associated to components. Column “resources to define a component” gives an idea of a system’s flexibility to create/execute work-

flows on CIGs so let us now explain these systems.

Trident (Barga et al., 2008) is a scientific WfMS that provides workflow provenance, schedule, and monitoring. However, there is a lack of extensibility features, especially to deal with external resources as a workflow task. To add a task it is necessary to extend a specific Microsoft .NET class or use external tools to import webservices.

VisTrails (Howe et al., 2008) has resources for visualization and creation of workflows by analogy, useful to provide easy use for non-IT specialists. Also, there is an exemplification mechanism that allow faster identification of the purpose of a task, which benefits workflow creation to achieve the goal. There is a versioning tree that allows to view changes made to workflows, which would be interesting to analyze different interventions applied to patients. The tool has limitations regarding the use of subworkflows and support to share and retrieve workflows, reducing its suitability on collaborative environment.

Kepler (Altintas et al., 2004) can execute tasks sequentially, paralleled, iteratively, etc. The WfMS supports a wide diversity of options to implement tasks, including webservices, R and XSTL. It is possible to register provenance information and to semantically annotate components, using URN (*Uniform Resource Name*), which is interesting to make links between semantically described clinical guidelines. The limitations found are the lack of a client-server architecture.

Taverna (Hull et al., 2006) does not have an intuitive interface, but is easy to extend and supports annotations, provenance and sub-workflows. Also, it allows a diverse use of resources to implement tasks, such as webservices, Java API and spreadsheets. Tasks can be organized hierarchically using sub-workflows.

ASBRU (Seyfang et al., 2002), part of Asgaard (Yuval Shahar and Johnson, 1998), allows the design and execution of tasks. The basic component of the work (a plan) can have different attributes and be composed by subplans, forming a hierarchy. Atomic units of plans are actions, which represent a specific tasks under a plan, and have the flexibility to be associated to a user interaction, external program or device. The work deals with context and provides flexibility to change and adapt to situations. It is done associating a set of attributes that are used to perform reasoning, trigger plans, change states and alter measure values. Such attributes are: preferences (constraints, e.g., strategy, utility and resources), intentions (goals), conditions (rules that govern state transition) and effects (known effects that plan arguments have over measurable parameters). From the infrastructure point of view of ASBRU and Asgaard

do not provide a flexible way to extend using plug-ins or modular components from third party developers, and do not implement security policies.

(Mikolajczak and Shenoy, 2010) developed Care-flow System, a WfMS developed for healthcare, using case handling technique to add the necessary flexibility inherent to the problem. The workflow can be executed in a flexible way because tasks are oriented to data and can be executed by different users. Each task has the flexibility to be executed, skipped or re-executed. As result of the case handling flexibility usage, the complexity to deal with context variables is transferred to users, who need to know about the case to deal appropriately with the task. To avoid the inadequate handling of tasks, there is an access control mechanism that associate users and tasks to roles. The system is developed over the YAWL WfMS, thus ensuring its important infrastructure features, such as reuse and share of workflows, flexibility to extend, client-service architecture, and flexibility to use external resources as tasks and support for subworkflows.

CPO (Ye et al., 2009) was developed focusing on healthcare applications. However, as the authors remark, their approach is different from those based on TNMs (e.g., ASBRU). “The tasks in clinical pathways are not decisions and actions recommended to clinicians, but the interventions to be performed by a multidisciplinary team by using healthcare resources, which contains not only clinicians but other healthcare professionals within one or more organizations.” As result, CPO is more similar to a traditional WfMS, with tasks that can be composed by subtasks, as workflows and subworkflows.

Perikles (Schick et al., 2012), also extends YAWL to increase the flexibility of a traditional WfMS, and makes it more suitable for healthcare applications. To this purpose, the work adds resources to control and plan tasks. Each task is specified under the HL7 standard, and may specify which tasks must be executed before or after another one, guiding users under activity planing.

ClinicSpace (Souza and Augustin, 2010) uses (Yamin et al., 2005) middleware to provide a tool to support collaboration and management of resources. The work is developed for pervasive and context-sensitive computing, interacting with sensors, devices and users. One of the main features is the recommendation of tasks based on task execution log.

The research analyzed can be classified in four main groups: scientific WfMSs ((Hull et al., 2006),(Howe et al., 2008), (Barga et al., 2008), and (Altintas et al., 2004)); business WfMSs ((Schick et al., 2012)); CIGs ((Seyfang et al., 2002), (Ye et al., 2009), and (Souza and Augustin, 2010)); hybrid ap-

proaches that extend or use WfMS to create a healthcare application.

Analysed WfMSs are extensible and, mostly, comply with open standards to connect with services; they support the management of provenance and annotation and can handle long transactions. The main workflow standards and/or tools have big libraries of shared workflows and support routines. Additionally, they allow the use of abstract activities, which can be associated to different resources, such as tools, documents or algorithms – provided as source code or service. Moreover, they commonly provide a more complete execution infrastructure with support to client-server architectures and allow the reuse of already existing resources. However, they lack support for dynamic self-adaptation, and do not provide support to context changes.

CIGs are essentially activity graphs and may accept the use of external resources. CIG execution systems are focused on guiding healthcare professionals through recommended actions and register, in a database, data from executed tasks or events. They are usually hierarchical (e.g., TNM approach) and embed the practices and usages of health guidelines. Moreover, they support definition of sets of conditions which tailor the actions to perform for each situation. In fact, such sets are nothing more than contexts for CIG execution.

An important characteristic found on CIGs is the approach to support the methodology and the pattern of work of healthcare professionals. It is essential to reduce the resistance that professionals may have to the use of a new tool, as well as reduce the learning curve to use it.

There is, also, initiatives that combine CIG and WfMS: (Dang et al., 2008), (Mikolajczak and Shenoy, 2010), and (Schick et al., 2012). Those tools are able to extend the properties of WfMSs, specializing its features to be used in healthcare domain. The result is the possibility to use the WfMS features we characterized as infrastructure, and the improvement of the tool to allow better usage for healthcare professionals. Some of the properties of WfMSs and CIGs, however, can be lost while processing a workflow or a guideline. (Mikolajczak and Shenoy, 2010), for example, add flexibility to workflows, but transfer to the user the responsibility to deal with context adaptations. (Schick et al., 2012) limits the use of external tools to those compliant with HL7 standards.

This comparative study guided our model of context, to extend scientific WfMSs. Figure 1 summarizes our perception as result of the comparative analysis presented in CIG systems. At the top, we show an abstract representation of the CIG approach to or-

ganize and handle tasks, as observed in CIG systems.

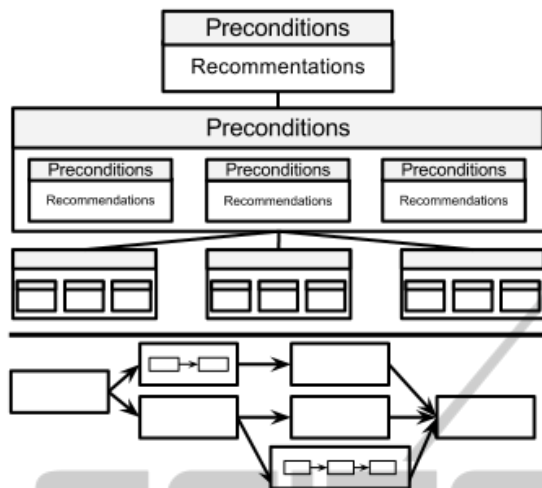

Figure 1: Organization of CIG and Workflow approaches as well as our proposed model.

Each box represents a plan whose execution is determined by the fulfilment of conditions, evaluated according to the state of variables, which we classify here as context variables. By context we mean, for example, the patient condition or the outcomes of a procedure. As illustrated in the figure, each plan can be decomposed in sub-plans, which in turn also have conditions defined by context variables – contextual conditions. We contrast this approach to the workflow approach illustrated at the bottom of Figure 1. Workflows are organized as a flow of tasks, whose connections are depicted by arrows. Even though workflows can decompose their tasks in sub-workflows, different from CIG systems, this composition is a reuse strategy and will not guide the workflow execution according contextual variables. This observation motivated our work of applying this CIG hierarchical decomposition, based on contextual variables, to workflows; resulting in our context-driven workflow mechanism, detailed in the next section.

This will be discussed further, using our real case study as a basis for nursing activities.

4 CHARACTERIZATION OF THE SCENARIO AND PROPOSAL

Our case study involves the PROCENF system (Peres et al., 2009) and nursing professionals from the hospitals from University of Campinas and University of São Paulo². Given this scenario, as well as the work described in (Doenges and Moorhouse, 2008),

we identified that a patient’s admission and monitoring process in a hospital can be expressed, in a general way, by the abstract workflow presented in Figure 2. This workflow reflects the patterns of the analysed CIGs, which are synthesized in table 3. The figure uses vocabulary from NANDA – North American Nursing Diagnosis Association – (Intl., 2012), NIC – Nursing interventions classification – (Sigsby and Campbell, 1995), and NOC – Nursing outcomes classification – (CNC, 2012). As can be seen, the workflow includes an iterative step in which a patient passes through anamnesis interrogation, an assessment phase. Then, there is the analysis of registered data to diagnose the problem and to identify expected outcomes (prognosis). Intervention planning and application phases occur to achieve an outcome. Outcome analysis consists in the analysis of intervention results, followed by updates to anamnesis records. If the treatment achieves expected outcomes, the patient can be released. Otherwise, a new iteration occurs.

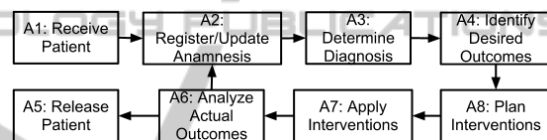

Figure 2: High level *Workflow* for healthcare treatment.

Health plans are characterized by progressively refinement by health professionals according to the context in which they are executed. While several “standard” procedures exist for a multitude of situations, each procedure is related to a given situation, or context, e.g., illness to be treated, patient anamnesis, and so on. However, depending on how a patient responds to interventions, a plan may change drastically. Thus, the execution of a sequence of tasks within a procedure is usually undertaken hierarchically: global procedures are defined in a high level manner, and undergo top-down refinement according to a given situation. Thus dynamics of this context-driven construction presents a marked contrast to other domains in which workflows or plans are conceived

If each procedure is defined as a workflow, this involves at least two aspects: (i) The execution of a given workflow may be suddenly interrupted to yield control to a different workflow dynamically defined by context and the original workflow may not even be ever resumed; (ii) Every workflow task subsumes

²The hospital complex of the University of Campinas alone receives about 500,000 appointments, with over 43,000 internments and 34,000 surgical interventions per year.

Table 2: Infrastructure characteristics of flow organized systems.

Work	Open Source	Flexibility	Annotation	Client-Server	Schedule	Provenance	Reuse/Share	Security
Trident (Barga et al., 2008)	+	-	-	+	+	Who executed, How long was execution, Associated data	Non integrated MyExperiment	User access and privilege control and workflow roles
VisTrails (Howe et al., 2008)	+	+	+	+	-	Who executed; Where; How long; etc. Flexible framework to extend features.	DB share; Synchronization; Versioning made by external resources, e.g. SVN.	-
Taverna (Hull et al., 2006)	+	+	+	+	-	Open Provenance Model: Executed service; Execution date; Parameters used.	MyExperiment Integrated	Secure services and user credentials
Kepler (Altintas et al., 2004)	+	+	+	-	-	Records provenance information	KAR files can be reused and shared. There is a central KAR repository.	-
ClinicSpace (Souza and Augustin, 2010)	-	-	-	+	-	Records provenance information	Allows the reuse of registered tasks	Limits the user access to tasks
ASBRU (Seyfang et al., 2002)	-	-	+	-	+	Temporal View provides events history.	Import, export, and duplicate plans	-
CPO (Ye et al., 2009)	-	-	-	+	+	-	Model created as ontology to be reused	-
Perikles (Schick et al., 2012) extending YAWL	?	?	±	+	+	Logging mechanism from YAWL	Provides reuse	±
Careflow (Mikolajczak and Shenoy, 2010) extending YAWL	+	+	+	+	+	Logging mechanism from YAWL	Provides reuse	Limits user's actions by roles and authorization.
(Dang et al., 2008)	-	-	+	+	+	Logging mechanism from BPEL Server	Provides reuse	Protects processes and encrypts communication

subworkflows that are chosen according to context.

The dynamic change of tasks implies on another important aspect to be treated: traceability. Not only does traceability play a major role, in the sense that all action and actors must be recorded, but requires a new dimension – one must also keep track of dynamic configurations (how, when, and by whom). It is fundamental to provide a history of steps performed, to allow to learn with experience from other professionals and to recognize which steps were decisive to the achieved outcomes. Because of this, provenance is an important feature that must be supported.

The analysis presented in the previous section stresses the importance of guiding the workflow execution by means of contextual variables, as observed in CIG systems. Our proposed architecture is able to extend a workflow engine to afford equivalent properties of a hierarchical decomposition based on contextual variables, as we will further detail.

Figure 3 shows the top level abstraction workflow to be executed, as portrayed in Figure 2. *CRec* is a dynamic data structure that records context variables at each instant. *CEng* is a context adaptation engine, an extension of a workflow engine, which monitors the context (*CRec*) and dynamically adapts workflow execution. The part shaded in gray represents the abstract activities yet to be executed under control of *CAEng*. The other abstract activities have already been refined and dashed line outlines the step executed under gradual refinement and execution.

Figure 3 illustrates two consecutive steps of a workflow execution carried by an engine, designed to support our context-based workflow customization and to allow to the user to interrupt or change the execution of an activity at any moment. In each step of the execution the *CAEng* monitors the running activity to capture context changes, updating the *CRec* (operation indicated by a dashed line). Whenever

Table 3: Basic component (BC) characteristics of flow organized systems.

Work	Type	BC	Resources to Combine Components	Flow Flexibility	BC Organization	Modelling of Context
Trident (Barga et al., 2008)	WfMS	Activity	Modified .NET classes; WebServices imported using external tool.	-	Sub-workflows	-
VisTrails (Howe et al., 2008)	WfMS	Activity	WebServices; Python Packages	-	Does not make clear that a workflow can be used as activity.	-
Taverna (Hull et al., 2006)	WfMS	Activity	WSDL/RESTful services, BioMart, BioMoby, SoapLab, Java APIs, R, Beanshell, Spreadsheets, Plugins to extend support.	-	Sub-workflows	-
Kepler (Altintas et al., 2004)	WfMS	Activity	WSDL/RESTful services, R, MatLab, Spreadsheets, command-line applications, XPath and XSLT;	-	Sub-workflows	-
ClinicSpace (Souza and Augustin, 2010)	CIG + middle-ware	Clinical Task	Limited to previously integrated tasks	Invoke tasks under certain conditions	Tasks and sub-tasks	Users, location, time and resources.
ASBRU (Seiffers et al., 2002)	CIG	Plans	User interaction and external tools and devices	Relationships and conditions change execution flow	Hierarchy	Conditions for plan activation
CPO (Ye et al., 2009)	CIG	Activity	Specification of interventions with associated values	?	Subprocess similar to subworkflows	?
Perikles (Schick et al., 2012) extending YAWL	CIG	Task	Service with HL7 compliant interfaces	?	Subworkflows	?
Careflow (Mikolajczak and Shenoy, 2010) extending YAWL	Case Handling + WfMS	Task	External applications, Java classes and webservices	Users can execute, redo, or skip task and change data at any time.	Tasks, Sub-Tasks and Workflows	Each task consider the entire case. Part of the context is handled by user
(Dang et al., 2008)	Ont. KB + BPEL server	Tasks	Web Service	Dynamic workflow composition and execution	Hierarchy	Yes

an activity finishes its execution, *CAEng* verify the new *CRec* state in order to apply modifications in the workflow (operation indicated by a gray area) if necessary. When the workflow starts, it has a starting *CRec* containing a set of basic context variables (see Figure 3 (i)), e.g., environment (e.g., type of medical facility), user, etc. The *Register/Update Anamnesis* is the main activity responsible for updating the *CRec*. Thus, the system can provide flexibility to change the flow of the execution, without force user to adapt the content to context.

5 CONCLUSIONS

The addition of dynamic self-adaptation capability to

scientific WfMSs can provide several advantages to healthcare activities. Benefits include automation and monitoring, and distributed execution of activities and the basis to support traceability of tasks and adaptations. Our work identified three important aspects that need to be considered: (i) Each task subsumes sub-workflows that are conducted/invoked dynamically according to a context; (ii) Tasks can be interrupted or changed, adding flexibility to the way that health activities are performed under a WfMS; (iii) Traceability must be provided to record changes performed, as well as to allow the improvement of activities by of analysis the historic data.

Those three aspects allow: to extend a WfMS creating a tool that maintains the hierarchical nature of clinical guidelines, to adapt the flow to the context and to analyse whether performed tasks can be trusted or

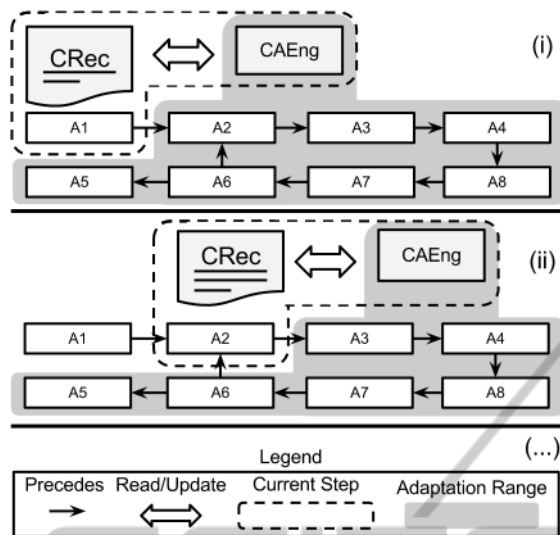

Figure 3: Adaptation of the flow of a workflow.

not. Also, the use of nursing standards contributes to better adaptation to healthcare workflows.

Future work includes the analysis and definition of context variables that will be used, resulting on a meta model and its instantiation. After this step, our model will be implemented in a scientific WfMS, which will be compared to the traditional approach, providing more evidences about advantages and disadvantages of the approaches.

ACKNOWLEDGEMENTS

Work partially financed by FAPESP (grant 2011/17196-0), the Microsoft Research FAPESP Virtual Institute (NavScales project), CNPq (grant 143483/2011-0, MuZOO Project and PRONEX-FAPESP), INCT in Web Science (CNPq 557.128/2009-9) and CAPES, as well as individual grants from CNPq. We also thank healthcare providers from University of Campinas and University of São Paulo, who provide us support in this research.

REFERENCES

- Altintas, I., Berkley, C., Jaeger, E., Jones, M., Ludascher, B., and Mock, S. (2004). Kepler: an extensible system for design and execution of scientific workflows. In *Proc. of 16th Intl. Conf. on Scientific and Statistical Database Management, 2004.*, pages 423–424. Ieee.
- Asfari, O., Doan, B., Bourda, Y., and Sansonnet, J. (2010). A Context-based Model for Web Query Reformulation. *limsi.fr*.
- Bandara, K., Wang, M., and Pahl, C. (2009). Dynamic Integration of Context Model Constraints in Web Service Processes. In *Software Engineering*. ACTA Press.
- Bardram, J. E. and Hansen, T. R. (2010). Context-Based Workplace Awareness. *Computer Supported Cooperative Work (CSCW)*, 19(2):105–138.
- Barga, R., Jackson, J., Araujo, N., Guo, D., Gautam, N., Grochow, K., and Lazowska, E. (2008). Trident: Scientific workflow workbench for oceanography. In *Services - Part I, 2008. IEEE Congress on*, pages 465–466.
- Barthelmeß, P. (1996). Sistemas de workflow: Análise da área e proposta de modelo. Master's thesis, Instituto de Computação - Unicamp.
- Bolchini, C., Curino, C. A., Quintarelli, E., Schreiber, F. A., and Tanca, L. (2007). A data-oriented survey of context models. *SIGMOD Rec.*, 36:19–26.
- Carmagnola, F., Cena, F., Gena, C., and Torre, I. (2005). A semantic framework for adaptive web-based systems. In *Proc. of SWAP*, pages 1613–0073. Citeseer.
- Cho, Y., Moon, J., and Yoe, H. (2010). LNCS 6018 - A Context-Aware Service Model Based on Workflows for u-Agriculture. *Technology*, pages 258–268.
- CNC (2012). Cnc - overview: Nursing outcomes classification (noc).
- Dang, J., Hedayati, A., Hampel, K., and Toklu, C. (2008). An ontological knowledge framework for adaptive medical workflow. *Journal of biomedical informatics*, 41(5):829–36.
- de Clercq, P. and Kaiser, K. (2008). Computer-interpretable guideline formalisms. *Studies in health technology*, pages 22–43.
- Deelman, E. and Chervenak, A. (2008). Data Management Challenges of Data-Intensive Scientific Workflows. *2008 Eighth IEEE Intl. Symposium on Cluster Computing and the Grid (CCGRID)*, pages 687–692.
- Deelman, E., Gannon, D., Shields, M., and Taylor, I. (2009). Workflows and e-Science: An overview of workflow system features and capabilities. *Future Generation Computer Systems*, 25(5):528–540.
- Dey, A. K. (2000). *Providing architectural support for building context-aware applications*. PhD thesis, Georgia Tech, Atlanta, GA, USA. AAI9994400.
- Din, M. A., Abidi, S. S. R., and Jafarpour, B. (2010). Ontology based modeling and execution of Nursing Care Plans and Practice Guidelines. *Studies in health technology and informatics*, 160(Pt 2):1104–8.
- Doenges, M. and Moorhouse, M. (2008). *Application of nursing process and nursing diagnosis: an interactive text for diagnostic reasoning*. G - Reference, Information and Interdisciplinary Subjects Series. F.A. Davis.
- El-Fakdi, A., Meléndez, J., and Petite, R. (2012). A proposal of a workflow-based cbr for interventional cdss - application to transcatheter aortic valve implantation (tavi). In *HEALTHINF*, pages 201–206.
- Fox, J., Patkar, V., Chronakis, I., and Begent, R. (2009). From practice guidelines to clinical decision support: closing the loop. *Journal of the Royal Society of Medicine*, 102(11):464–73.

- Hollingsworth, D. and Others (1993). Workflow management coalition: The workflow reference model. *Workflow Management Coalition*, (1):1–55.
- Howe, B., Lawson, P., Bellinger, R., Freire, J., Anderson, E., Santos, E., Scheidegger, C., Baptista, A., and Silva, C. (2008). End-to-end escience: Integrating workflow, query, visualization, and provenance at an ocean observatory. In *Proc. of the 2008 Fourth IEEE Intl. Conf. on eScience*, pages 127–134.
- Hull, D., Wolstencroft, K., Stevens, R., Goble, C., Pocock, M. R., Li, P., and Oinn, T. (2006). Taverna: a tool for building and running workflows of services. *Nucleic acids research*, 34(-):W729–32.
- Intl., N. (2012). *Nursing Diagnoses: Definitions and Classification 2012-14 (NANDA Intl. Nursing Diagnosis)*. Wiley.
- Kholladi, M. and Doan, B. (2010). PRESY: A Context Based Query Reformulation Tool for Information Retrieval on the Web. *Annals of Physics*, 54(4):258.
- Leong, T. Y., Kaiser, K., and Miksch, S. (2007). Free and open source enabling technologies for patient-centric, guideline-based clinical decision support: a survey. *Yearbook of medical informatics*, (April):74–86.
- Lundberg, J. (2007). *Principles of workflow support in life critical situations. Licentiate thesis, School of Engineering, Blekinge Institute of Technology*.
- Lundberg, J. and Rune, G. (2009). Robust approach towards context dependant information sharing in distributed environments. *ICEIS09, Milan, Italy*.
- Medeiros, C. B., Prez-Alcazar, J., Digiampietri, L., Jr., G. Z. P., Santanch, A., da Silva Torres, R., Madeira, E., and Bacarin, E. (2005). Woodss and the web: Annotating and reusing scientific workflows. *SIGMOD Record*, 34(3):18–23.
- Mikolajczak, B. and Shenoy, M. (2010). Flexibility through case handling in careflow systems: A case study of cutaneous melanoma. In *Health Care Management (WHCM), 2010 IEEE Workshop on*, pages 1–6.
- Millard, I. C., Roure, D. D., and Shadbolt, N. (2004). The use of ontologies in contextually aware environments. In Indulska, J. and Roure, D. D., editors, *Proc. of First Intl. Workshop on Advanced Context Modelling, Reasoning And Management*, pages 42–47, Nottingham, UK.
- Ogasawara, E., Murta, L., Werner, C., and Mattoso, M. (2008). Linhas de Experimento: Reutilização e Gerência de Configuração em Workflows Científicos. In *2 E-Science Workshop co-locado ao SBBD/SBES*, pages 31–40.
- Panzarasa, S. and Stefanelli, M. (2006). Workflow management systems for guideline implementation. *Neurological sciences : official journal of the Italian Neurological Society and of the Italian Society of Clinical Neurophysiology*, 27 Suppl 3:S245–9.
- Peres, H. H. C., Cruz, D. D. A. L. M. D., Lima, A. F. C., Gaidzinski, R. R., Ortiz, D. C. F., Trindade, M. M. E., Tsukamoto, R., and Conceição, N. B. (2009). Desenvolvimento de Sistema Eletrônico de Documentação Clínica de Enfermagem estruturado em diagnósticos, resultados e intervenções. *Revista da Escola de Enfermagem da USP*, 43(spe2):1149–1155.
- Riaño, D., Real, F., López-Vallverdú, J. A., Campana, F., Ercolani, S., Mecocci, P., Annicchiarico, R., and Caltagirone, C. (2012). An ontology-based personalization of health-care knowledge to support clinical decisions for chronically ill patients. *Journal of biomedical informatics*.
- Scheidegger, C. E., Vo, H. T., Koop, D., Freire, J., and Silva, C. T. (2008). Querying and re-using workflows with VsTrails. *Proc. of the 2008 ACM SIGMOD intl. conf. on Management of data - SIGMOD '08*, page 1251.
- Schick, S., Meyer, H., Bandt, M., and Heuer, A. (2012). Enabling yawl to handle dynamic operating room management. In Daniel, F., Barkaoui, K., and Dustdar, S., editors, *Business Process Management Workshops (2)*, volume 100 of *Lecture Notes in Business Information Processing*, pages 249–260. Springer.
- Seyfang, A., Miksch, S., and Marcos, M. (2002). Combining diagnosis and treatment using ASBRU. *Intl. journal of medical informatics*, 68(1-3):49–57.
- Shahar, Y., Miksch, S., and Johnson, P. (1998). The asgaard project: a task-specific framework for the application and critiquing of time-oriented clinical guidelines. *Artificial Intelligence in Medicine*, 14(1?2):29–51.
- Sigsby, L. M. and Campbell, D. W. (1995). Nursing interventions classification: A content analysis of nursing activities in public schools. *Journal of Community Health Nursing*, 12(4):229–237.
- Souza, M. V. B. and Augustin, I. (2010). Inferência de Atividades Clínicas a partir de Propriedades do Contexto. *Interface*, pages 1717–1726.
- Strang, T., Linnhoff-popien, C., and Frank, K. (2003). CoOL: A Context Ontology Language to Enable Contextual Interoperability. *Ifip Intl. Federation For Information Processing*, pages 236–247.
- Turner, R. (1999). A model of explicit context representation and use for intelligent agents. *Modeling and Using Context*, pages 831–831.
- Yamin, A., Augustin, I., da Silva, L. C., Real, R. A., Filho, A. E. S., and Geyer, C. F. R. (2005). Exehda: adaptive middleware for building a pervasive grid environment. In *Proc. of the 2005 conf. on Self-Organization and Autonomic Informatics (I)*, pages 203–219, Amsterdam, The Netherlands. IOS Press.
- Ye, Y., Jiang, Z., Diao, X., Yang, D., and Du, G. (2009). An ontology-based hierarchical semantic modeling approach to clinical pathway workflows. *Comput. Biol. Med.*, 39(8):722–732.
- Yuval Shahar, S. M. and Johnson, P. (1998). The Asgaard project: a task-specific framework for the application and critiquing of time-oriented clinical guidelines. *Artificial intelligence in medicine*, 14(1-2):29–51.