

THEORETICAL CALCULATION OF THERMAL CONTACT RESISTANCE OF BALL BEARING UNDER DIFFERENT LOADS

Chao Jin, Bo Wu

*State Key Laboratory for Digital Manufacturing Equipment and Technology
Huazhong University of Science and Technology, Wuhan, Hubei 430074, China*

Youmin Hu

School of Mechanical Science and Engineering, Huazhong University of Science and Technology

Keywords: Hertzian theory, JHM method, Load distribution, Thermal contact resistance.

Abstract: The thermal contact resistance between the balls and the inner and outer rings of an angular contact ball bearing is investigated. It is assumed that the bearing sustains thrust, radial, or combined loads under a steady-state temperature condition. The shapes and sizes of the contact areas are calculated using the Hertzian theory. The distribution of internal loading in the bearing is determined by the JHM method. The comparison between the experimental data and the calculated values confirms the validity of the prediction method for the thermal contact resistances between the elements of a bearing.

1 INTRODUCTION

In a high-speed feeding system, bearings are considered to be the main heat sources, and the thermal properties of the bearings need to be carefully studied. For a bearing, the thermal resistances for conduction through the bearing elements themselves and for radiation can be calculated using the dimensions, the thermal conductivities, the thermal-optical properties, and the temperatures of the elements. However, it can be said that the thermal contact resistances between the balls and the rings, which are most closely related to the temperature differences across the bearings, are difficult to predict because few useful calculation methods have been proposed yet.

Since the thermal resistance results from the fact that most of the heat is constrained to flow through small contact areas, a reasonable step in determining the contact resistance between the balls and the inner and outer rings of the bearing would be to use a similar approach to that adopted to solve the thermal constriction problem for ideal smooth surfaces. The thermal constriction resistances for circular, circular annular, rectangular, and other geometrical-shaped contact areas are normally solved analytically or numerically as Dirichlet problems. The prediction of the thermal contact resistance necessitates the

determination of the contact area. This is possible with the Hertzian theory when the contact surfaces are approximated as being smooth. In addition to the study by Clausing and Chao, the thermal contact resistance problem has been discussed in many papers. Most papers determine the contact areas using the Hertzian theory. However, a survey of the literature shows that only the studies by Yovanovich have dealt with the problem of the contact resistance between bearing elements. He studied the contact resistance under axial loads and concluded that the contact resistance depends on the size and shape of contact area as determined by the Hertzian theory and the thermal conductivity of the material. He did not, however, give thermal designers a tractable expression that considered the change in contact angle induced by elastic deformation at the contact points. Also, he did not consider other types of loadings such as radial and combined axial/radial loads.

This article develops an approach that accurately predicts the thermal contact resistance between the balls and the inner and outer rings of an angular contact ball bearing. The contact forces required to calculate the contact area are explicitly formulated for axial, radial, and combined loadings. The prediction method for the thermal contact resistance is verified by comparing the calculated values with

experimental results measured in a high-speed feeding system.

2 EXPRESSIONS FOR CONTACT RESISTANCE

2.1 Contact Resistance

The contact resistances between the balls and the inner and outer rings may be treated in the same manner as constriction resistance since both resistances result from the restriction of the heat flow due to small contact areas. Thus, the assumptions utilized to solve the constriction resistance may be applicable to the present problem. It is assumed that one half of the thermal constriction resistance problem can be adequately represented by an isolated, isothermal area either supplying or receiving heat from an other-wise insulated conducting half-space. In the ellipsoidal coordinate system the Laplace's equation is:

$$\nabla^2 T = \frac{\partial}{\partial u} (\sqrt{f(u)} \frac{\partial T}{\partial u}) \tag{1}$$

Where

$$\sqrt{f(u)} = \sqrt{(a^2 + u)(b^2 + u)u} \tag{2}$$

And a, b are the semi-major and semi-minor axes of the elliptic contact area, respectively; while u is the variable along an axis normal to the contact plane. The boundary conditions are:

$$u = 0, T = T_0, \text{ const} \tag{3}$$

$$u \rightarrow \infty, T = 0 \tag{4}$$

With Equation (1), (3) and (4), the temperature distribution can be obtained:

$$T = \frac{Q}{4\pi k} \int_u^\infty \frac{du}{\sqrt{f(u)}} \tag{5}$$

Where Q is all the heat leaving the elliptic contact area, and by the definition of the thermal contact resistance:

$$R = \frac{T_0 - T_{u \rightarrow \infty}}{Q} = \frac{1}{4\pi k} \int_0^\infty \frac{du}{\sqrt{f(u)}} \tag{6}$$

Using the complete elliptic integral of the first kind, Equation (6) can be written in the following form as:

$$R = \frac{\Psi(a/b)}{4ka}, \Psi(a/b) = \frac{2}{\pi} F(e, \frac{\pi}{2}) \tag{7}$$

Then, the contact thermal resistance between the ball and the inner or outer ring can be determined by using Equation (7). For most bearing, whose ball and both rings are made from the same material, i.e., $k = k_b = k_i = k_o$, we can write the contact thermal resistance per ball as:

$$R = \frac{1}{2k} \left[\frac{\Psi(a_i/b_i)}{a_i} + \frac{\Psi(a_o/b_o)}{a_o} \right] \tag{8}$$

These expressions permit us to predict the total contact resistance resulting from the contact of an arbitrary number of balls with both the inner and outer rings by connecting the thermal resistances in parallel.

2.2 Contact Areas in a Ball Bearing

The thermal contact resistance is generally considered as a function of the shape and size of the contact area. When two elastic bodies having smooth round surface are pressed against each other, the contact area becomes elliptic. The formulations that determine the semi-major and semi-minor axes of the elliptic contact area are summarized herein. In deriving the following expressions, it is assumed that the angle between the two planes containing the principal radii of curvature of the bodies are perpendicular as in the case of balls contacting the inner or outer ring of a bearing:

$$a = a^* \left[\frac{3}{4} \frac{P}{A+B} \left(\frac{1-\nu_1^2}{E_1} + \frac{1-\nu_2^2}{E_2} \right) \right]^{1/3} \tag{9}$$

$$b = b^* \left[\frac{3}{4} \frac{P}{A+B} \left(\frac{1-\nu_1^2}{E_1} + \frac{1-\nu_2^2}{E_2} \right) \right]^{1/3}$$

$$A = \frac{1}{2} \left(\frac{1}{r_1} + \frac{1}{r_2} \right), B = \frac{1}{2} \left(\frac{1}{r_1} - \frac{1}{r_2} \right) \tag{10}$$

In which r_1, r_1' are the radius of curvature for inner or outer race and groove, respectively. And r_2, r_2' are the radii of rolling ball. Considering the bearing model shown in Figure 1, for the contact at inner ring side, the radius of curvature r_1' of the inner groove must be treated as negative in Equation (10); while at the outer ring side contact, r_1, r_1' must be treated as negative.

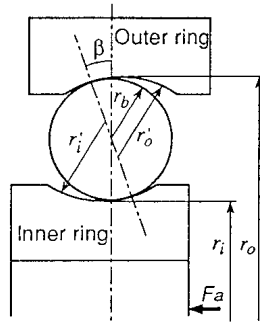

Figure 1: Schematic of bearing.

The values of a^* and b^* are calculated as follows:

$$\begin{cases} I = \frac{2}{e^2} [F(e, \frac{\pi}{2}) - E(e, \frac{\pi}{2})] \\ J = \frac{2}{e^2} [\frac{E(e, \frac{\pi}{2})}{1-e^2} - F(e, \frac{\pi}{2})] \\ \frac{J}{I} = \frac{A}{B} \end{cases} \quad (11)$$

In which $F(e, \frac{\pi}{2})$ and $E(e, \frac{\pi}{2})$ are the complete elliptic integrals of the first and second, respectively.

$$\begin{aligned} F(e, \frac{\pi}{2}) &= \int_0^{\pi/2} (1 - e^2 \sin^2 \Phi)^{-\frac{1}{2}} d\Phi \\ E(e, \frac{\pi}{2}) &= \int_0^{\pi/2} (1 - e^2 \sin^2 \Phi)^{\frac{1}{2}} d\Phi \end{aligned} \quad (12)$$

Equation (11) can be solved numerically by the Newton-Downhill method, and then e can be determined, the value of I and J can be calculated. Finally,

$$a^* = (\frac{I+J}{\pi})^{1/3}, b^* = a^* (1 - e^2)^{1/2} \quad (13)$$

3 LOAD TYPES AND CONTACT FORCE

We can now use Equation (8) for the prediction of the thermal contact resistance if the contact force for each ball is determined from the total load on the bearing.

3.1 Contact Force Under Centric Thrust Load

Angular contact ball bearings subjected to a centric

thrust load have the load distributed equally among the rolling elements. Hence

$$Q = \frac{F_a}{Z \sin \alpha} \quad (14)$$

Where α is the contact angle that occurs in the loaded bearings, and can be determined as follows. In the unloaded condition, the initial contact angle is defined by

$$\cos \alpha^0 = 1 - \frac{P_d}{2BD} \quad (15)$$

In which B is the total curvature, and P_d is the mounted diametral clearance.

$$P_d = d_o - d_i - 2D \quad (16)$$

A thrust load F_a applied to the inner ring as shown in Figure2 causes an axial deflection δ_a . This axial deflection is a component of a normal deflection along the line of contact such that from Figure2.

$$\delta_n = BD (\frac{\cos \alpha^0}{\cos \alpha} - 1) \quad (17)$$

Since $Q = K \delta_n^{1.5}$, where K is the load-deflection factor. Substituting Equation (17) into (14), we get,

$$\frac{F_a}{ZK(BD)^{1.5}} = \sin \alpha (\frac{\cos \alpha^0}{\cos \alpha} - 1)^{1.5} \quad (18)$$

Equation (18) may be solved numerically by the Newton-Raphson method, the equation to be satisfied iteratively is,

$$\alpha' = \alpha + \frac{\frac{F_a}{ZK(BD)^{1.5}} - \sin \alpha (\frac{\cos \alpha^0}{\cos \alpha} - 1)^{1.5}}{\cos \alpha (\frac{\cos \alpha^0}{\cos \alpha} - 1)^{1.5} + 1.5 \tan^2 \alpha \cos \alpha^0 (\frac{\cos \alpha^0}{\cos \alpha} - 1)^{0.5}} \quad (19)$$

Equation (19) is satisfied when $\alpha' - \alpha$ is essentially zero. Simultaneously, from Fig.2, we can get

$$\delta_a = \frac{BD \sin(\alpha - \alpha^0)}{\cos \alpha} \quad (20)$$

3.2 Contact Force Under Combined Radial and Thrust Load

If rolling bearing without diametral clearance is subjected simultaneously to a radial load in the central plane of the roller and a centric thrust load, then the inner rings of the bearing will remain parallel and will be relatively displaced a distance δ_a in the axial direction and δ_r in the radial direction. At any position Ψ measured from the most

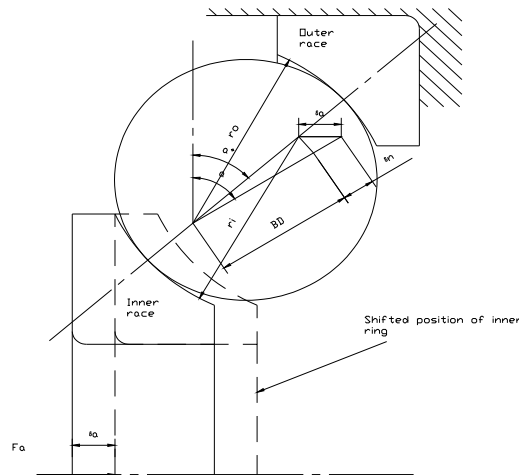

Figure 2: Angular contact ball bearing under thrust load.

heavily loaded rolling element, the approach of the rings is,

$$\delta_\psi = \delta_a \sin \alpha + \delta_r \cos \alpha \cos \psi \quad (21)$$

At $\Psi=0$ maximum deflection occurs and is given by

$$\delta_{\max} = \delta_a \sin \alpha + \delta_r \cos \alpha \quad (22)$$

Combining Equation (21) and (22) yields

$$\delta_\psi = \delta_{a \max} \left[1 - \frac{1}{2\varepsilon} (1 - \cos \psi) \right] \quad (23)$$

In which

$$\varepsilon = \frac{1}{2} \left(1 + \frac{\delta_a \tan \alpha}{\delta_r} \right) \quad (24)$$

It should also be apparent that

$$Q_\psi = Q_{a \max} \left[1 - \frac{1}{2\varepsilon} (1 - \cos \psi) \right]^{1.5} \quad (25)$$

For static equilibrium to exist, the summation of rolling element forces in each direction must equal the applied load in that direction.

$$\begin{cases} F_r = \sum_{\psi=-\psi_1}^{\psi_1} Q_\psi \cos \alpha \cos \psi \\ F_a = \sum_{\psi=-\psi_1}^{\psi_1} Q_\psi \sin \alpha \end{cases} \quad (26)$$

In which Ψ_1 is the limiting angle defined as follow,

$$\psi_1 = \cos^{-1} \left(-\frac{\delta_a \tan \alpha}{\delta_r} \right) \quad (27)$$

Using the integral form of $J_r(\varepsilon)$ and $J_a(\varepsilon)$ introduced by Sjövall, Equation (26) may be written in equations system form.

$$\begin{cases} F_r \\ F_a \end{cases} = ZQ_{\max} \begin{cases} J_r(\varepsilon) \cos \alpha \\ J_a(\varepsilon) \sin \alpha \end{cases} \quad (28)$$

$$= ZK(\delta_a \sin \alpha + \delta_r \cos \alpha) 1.5 \begin{cases} J_r(\varepsilon) \cos \alpha \\ J_a(\varepsilon) \sin \alpha \end{cases}$$

where $J_r(\varepsilon)$ and $J_a(\varepsilon)$ are defined as follows,

$$\begin{cases} J_r(\varepsilon) = \frac{1}{2\pi} \int_{-\psi_1}^{\psi_1} \left[1 - \frac{1}{2\varepsilon} (1 - \cos \psi) \right]^{1.5} \cos \psi d\psi \\ J_a(\varepsilon) = \frac{1}{2\pi} \int_{-\psi_1}^{\psi_1} \left[1 - \frac{1}{2\varepsilon} (1 - \cos \psi) \right]^{1.5} d\psi \end{cases} \quad (29)$$

The values of the integrals of Equation (28) can be get using Simpson Integral Method, Fig.3 gives the values of $J_r(\varepsilon)$ and $J_a(\varepsilon)$.

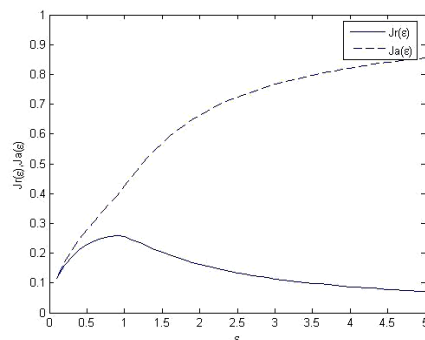

Figure 3: $J_r(\varepsilon)$ and $J_a(\varepsilon)$ vs. ε for angular contact ball bearing.

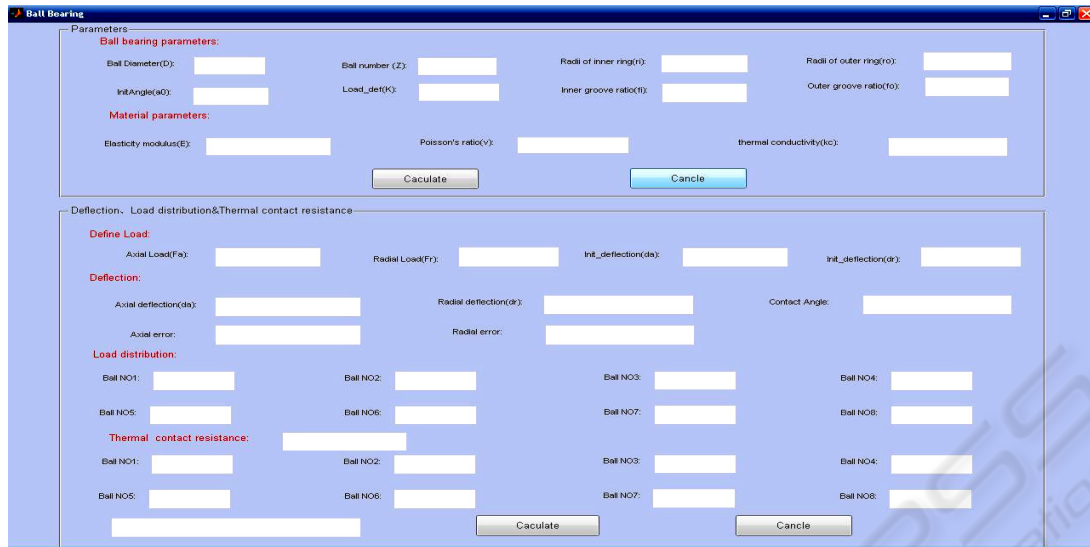

Figure 5: interface of calculation software for thermal contact resistance.

The nonlinear equations system has to be solved by iteration, so the Newton-Raphson method can be applied. When the axial deflection δ_a and the thrust deflection δ_r is determined, the contact force on each ball can be calculated by

$$Q_{\psi} = K\delta_{\psi}^{1.5} = K(\delta_a \sin a + \delta_r \cos a \cos \psi)^{1.5} \quad (30)$$

3.3 Contact Force Under Radial Load

Considering the structure of angular contact balling bearing, when subjected to purely radial load F_r , the normal force Q_i of the rolling element can be decomposed into radial load component Q_{ir} and axial load component Q_{ia} (as shown in Figure 4). The sum of every axial load component was called derivative axial force S , which can be calculated as follows:

$$S = 1.25F_r \tan \alpha \quad (31)$$

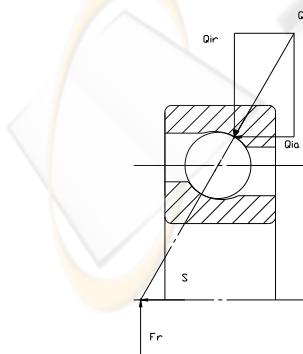

Figure 4: Derivative axial force.

To summarize, when rolling bearing is subjected to purely radial load, an additional derivative axial force is brought out. In this situation, the bearing can be treated as being subjected to simultaneously to a radial load and a centric thrust load.

4 CALCULATION SOFTWARE AND AN EXAMPLE

4.1 Calculation Software

A calculation software has been made using the MATLAB/GUI, whose interface is shown in Fig. 5 below.

The calculation procedure of thermal contact resistance of ball bearing is as follows:

- 1) Input following parameters of the ball bearing: ball diameter, ball number, radii of inner and outer ring, ratio of inner and outer groove, and the material properties, such as the modulus of elasticity, Poisson's ratio and the thermal conductivity.
- 2) Calculate the initial contact angle and the load-deflection coefficient of the bearing, which are useful in the calculation.
- 3) Define the loads of the bearing, and then the load form is analysed.
 - a) If the radial load $F_r=0$, a supposed axial deflection value is needed.
 - b) If both the axial and radial loads are positive, supposed axial and radial deflection values must be input for the

calculation.

- 4) The axial/radial deflection value and the final contact angle are calculated.
- 5) Finally, the normal load and thermal contact resistance of each ball are obtained.
- 6) The overall thermal contact resistance of the bearing can be get by connecting the thermal resistance of each ball in parallel.

Take the following bearing as an example: the bearing has 7 spherical balls, and all elements are made from steel 440C; the diameter of the balls, $2r_b$, is 9.525 mm ; the groove radii r_i' and r_o' are $1.03937r_b$, and the race radii r_i and r_o are $3.06037r_b$ and $5.06562r_b$, respectively; the inner and outer bearing diameters are 22mm and 56mm.

4.2 Contact Force Under Centric Thrust Load

In this case, the bearing is subjected to varied thrust load (F_a) ranging from 20 to 200 N with a span of 10 N. The calculated thermal contact resistances are shown in Figure 6.

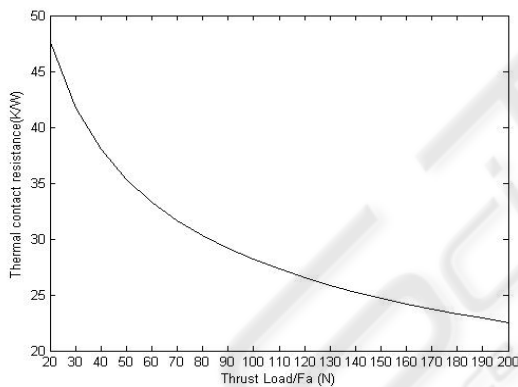

Figure 6: Thermal contact resistance under thrust load.

From Figure 6, we can see with the thrust load increasing, the thermal contact resistance decreases. That is because when the thrust load increases, the normal load of each ball increases, then the contact area extends.

4.3 Contact Force Under Combined Radial and Thrust Load

In this case, the bearing is subjected simultaneously to radial load of 20, 50, 80, 120 N, and varied thrust load ranging from 20 to 200 N with a span of 5 N. The calculated thermal contact resistances are shown in Figure 7.

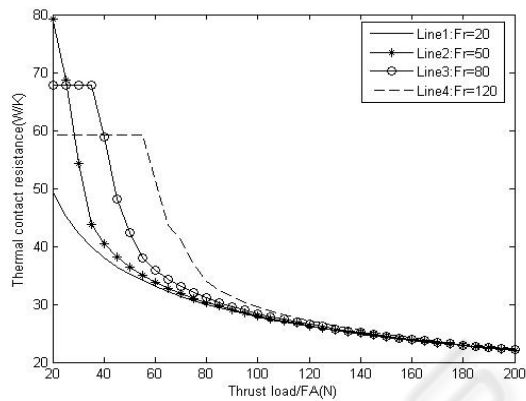

Figure 7: Thermal contact resistance under combined thrust and radial load.

From Figure 7, we can see Line1 represents much the same way as the line in Fig.4; While for Line2, when the thrust load F_a increases from 20 to 40 N, the thermal contact resistance changes rapidly. That's because the number of balls subjected to normal load Q_i changes from 1 to 4; For Line3, when the thrust load F_a changes from 20 to S (derivative axial force, for $F_r=80\text{N}$, $S=38.5\text{N}$), because F_a is smaller than S , the thrust load of the bearing F_a keeps $F_a=S$, and the thermal contact resistance stays at 67.76 W/K , with only 1 ball subjected to normal load Q_i . The following part of Line3 represents the same way as Line2; Line4 is like Line3.

In another way, for the thrust load $F_a=100\text{N}$, the contact resistance of each line is 27.80, 28.00, 28.41, and 29.54, respectively. For combined thrust load $F_a=100\text{N}$ and $F_r=20\text{N}$, the contact resistance of each ball (as shown in Fig.6) is 185.19, 188.53, 196.74 and 204.17, respectively; for $F_a=100\text{N}$ and $F_r=50\text{N}$, that is 173.85, 181.04, 201.08 and 223.07; for $F_a=100\text{N}$ and $F_r=80\text{N}$, that becomes 164.55, 174.68, 206.62 and 250.58; and for $F_a=100\text{N}$ and $F_r=120\text{N}$, that is 173.85, 181.04, 201.08 and 223.07, respectively.

As mentioned above, the total contact resistance is calculated by connecting that of every ball in parallel. Since the load distribution of Line1 is much more uniform than the others, the total contact resistance of Line1 is smaller.

5 EXPERIMENTAL RESULTS AND COMPARISON

A test program was conducted in order to verify the prediction method of the thermal contact resistance.

Table 1: Experimental results and predictions.

Test Case no.	Load, N		Temperature, K		Q, W	R_{i_o} K/W	R_s K/W	Measured, R K/W	Predicted, R K/W
	Thrust	Radial	inner	outer					
1	39.2	0	298.2	334.8	0.88	41.59	2.2	39.39	38.24
2	0	98.1	300.3	336.8	0.54	67.3	2.2	65.1	63.30
3	39.2	39.2	300.3	329.1	0.68	42.60	2.2	40.40	39.44

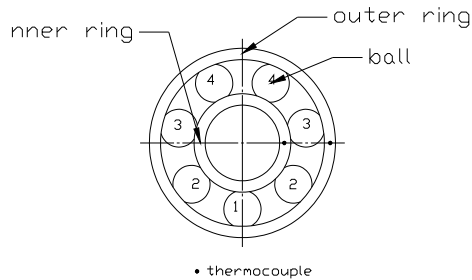

Figure 8: Ball positions and temperature measurement points (Supposing the balls locate symmetrically).

The experimental apparatus is shown in Figure 9, using thermocouples as sensors. The dimensions and material properties of the bearing matched those described previously. The thrust and radial load was imposed by adjusting the pressure of the hydraulic devices. Figure 8 and 10 show the temperature measurement points on the bearing and the shaft. The test parameters were shown in Table. The temperatures shown in Table were obtained under steady-state conditions when temperature changed less than $\pm 0.2^\circ\text{C}$.

In the experiment, the bearing was considered as the heat source. The conductive heat flow through the shaft Q was calculated by,

$$Q = Sk_s \left(\frac{T_1 - T_2}{l_{12}} + \frac{T_3 - T_4}{l_{34}} \right) \quad (32)$$



Figure 9: High-speed experimental bench for thermal contact resistance measurement.

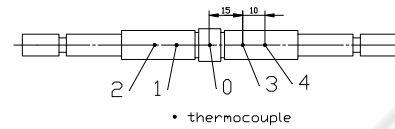

Figure 10: Temperature measurement points on shaft.

Where T_i , T_o and R_s denoted the measured temperatures of the inner and outer rings, and the conductive resistance for the solid existing between the measurement points.

A comparison of the test result and the prediction values is given in Table 1, and the agreement between both results is excellent. Therefore, we can say that the calculation method is applicable to the prediction of contact resistance between the elements of a angular contact ball bearing sustaining thrust, radial and combined loads.

6 CONCLUSIONS

A calculation method based on precisely determined contact forces has been presented to predict the thermal contact resistance between the balls and the inner and outer rings of a space-use dry bearing. The study assumed that a stationary ball bearing sustained axial, radial, or combined loads under a steady-state temperature condition. While the thermal analysis method is the same as that employed to determine constriction resistance, the assumptions commonly utilized in the constriction problem have been numerically confirmed to be applicable to the prediction of the contact resistance between the bearing elements. Also, the calculation of the contact resistance has indicated that the careful consideration of changes in the contact angle is important to determine the contact force and area due to the axial loads.

For the load types dealt with, limited test data were used to verify the proposed method because it was not easy to get the same temperature distribution across the bearing when the magnitude of load was changed, and the total number of operations had to be restricted to avoid changing the surface condition. However, it can be said that the

excellent agreement between the test results and the predictions has confirmed the applicability of the proposed calculation method.

ACKNOWLEDGEMENTS

The work is supported by the National Natural Science Foundation of China (No. 50675076), the National Key Basic Research Special Found of China (No.2005CB724100) and National Natural Science Foundation of China (No. 50575087).

REFERENCES

- Yovanovich, M. M., 1975. Thermal Constriction Resistance of Contacts on a Half-Space: Integral Formulation, *AIAA Paper 75-708*.
- Clausing, A. M., Chao, B. T., 1965. Thermal Contact Resistance in Vacuum Environment, *Transactions of the American Society of Mechanical Engineers, Ser. C., Vol. 87: 243-251*.
- Madhusudana, C. V., Fletcher, L. S., 1986. Contact Heat Transfer—the Last Decade, *AIAA Journal, Vol. 24, No. 3:510-523*.
- Yovanovich, M. M., 1986. Recent Development in Thermal Contact, Gap and Joint Conductance Theories and Experiment, *Proceedings of the 8th International Heat Transfer Conference (San Francisco, CA): 35-45*.
- Yovanovich, M. M., 1986. Thermal Contact Resistance Across Elastically Deformed Spheres, *Journal of Spacecraft and Rockets, Vol.4, No. 1: 119-12*.
- Yovanovich, M. M., 1986. Thermal Constriction Resistance Between Contacting Metallic Paraboloids: Application to Instrument Bearings, *AIAA Paper 70-857*.
- Love, A. E. H., 1944. *A Treatise on the Mathematical Theory of Elasticity*, Dover, New York, 4th edition.
- Cooper, D. H., 1969. Hertzian Contact-Stress Deformation Coefficients, *Journal of Applied Mechanics*, Vol. 36: 296-303.
- Harris, T.A., 2001. *Rolling Bearing Analysis*, John Wiley & Sons, Inc., New York, 5th edition