

DETECTING TRANSIENT WEATHER PHENOMENA ON MARS

An Overview of the Design and Calibration of Multiparametric Detection Algorithms for the REMS/MSL Mission

J. Verdasca, J.-A. Manfredi and V. Peinado
*Centro de Astrobiología, Instituto Nacional de Técnica Aeroespacial
Ctra. de Torrejón a Ajalvir Km 4, Torrejón de Ardoz, Madrid, Spain*

Keywords: Multiple-scale phenomena, change detection, autonomous decision, multiparametric algorithms.

Abstract: In its baseline operation mode, the REMS/MSL mission is not well suited to characterize transient weather phenomena evolving on multiple scales. In this paper we argue that this limitation can be overcome by enabling REMS to autonomously detect sudden and unexpected changes in the acquired data and subsequently extend the time allocated for measurements. Detection is accomplished by means of multiparametric Event-Finding Algorithms running on the REMS micro-controller. We describe the principles underlying the design of such algorithms and the methods for their calibration.

1 DESCRIPTION OF REMS

The Rover Environmental Monitoring Station (REMS) is an instrument suite to be carried aboard the Mars Science Laboratory (MSL) rover. It is being developed and integrated at the Centro de Astrobiología (CAB/(CSIC-INTA)) as a contribution of the Spanish Government. REMS comprises two booms attached to the rover mast at an angle of 120 degrees (Figure 1).

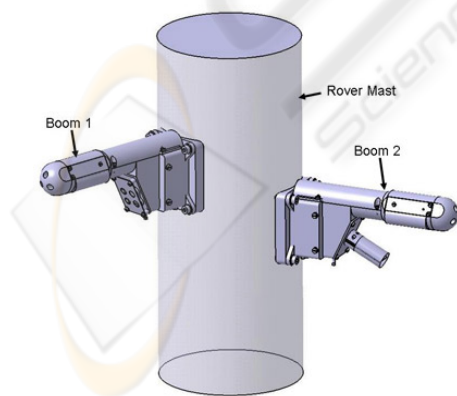

Figure 1: REMS booms with sensors.

Each of the booms carries a wind sensor and an air temperature sensor. An infrared sensor mounted on the electronics casing of boom 1, facing the ground,

will measure the brightness temperature of the martian surface. On boom 2 there is a humidity sensor (the protruding cylindrical structure on the figure) provided by the Finnish Meteorological Institute (FMI). A pressure sensor, (not shown here) also built by the FMI, is mounted below the rover deck, being in contact with the atmosphere through a small opening. Finally, an UV sensor (also not shown), located on top of the rover deck, will measure the irradiation intensity in six different bands. REMS features a small embedded computer system whose main task is to act as an Interface Control Unit but is also capable of executing simple programs.

2 THE REMS/MSL MISSION

2.1 Science Goals

The MSL mission will assess the present and past habitability of Mars. REMS will contribute by monitoring the physical processes taking place in the layer of the atmosphere closest to the surface. Scientists believe that if life exists on Mars it will most likely be found in tiny pockets of liquid water in porous rock beneath the surface. Local weather patterns likely play a fundamental role in the ability of sheltered environments to retain liquid subsurface

water. For instance, the regime of local winds may impact the cycles of freezing and thawing of permafrost soils inside craters and on the slopes of mountains, cliffs or hills. Indeed, recent images obtained from orbit show gullies and trenches that seem to have been made by water outpouring at certain localized spots and flowing down the slopes. An alternative explanation, which rules out liquid water, sustains that the gully-like features are caused by small landslides triggered by wind. Hence, one of the main goals of REMS is to shed light on the regime of local winds to enhance our ability to distinguish between features most likely due to aeolian erosion from those which could possibly have been carved by liquid water.

2.2 Limitations of REMS Baseline

The baseline currently being considered for REMS Nominal Mode (NM) operation consists in 24 sessions per sol of 5 minutes each, comprising a data acquisition cycle at a sampling rate of 1 Hz. Thus, REMS ability to characterize short range multiple-scale events is limited. In this position paper we argue that this limitation can be overcome by providing REMS with the capability to carry out Opportunistic Science. We outline the strategy we are pursuing to this aim, and lay down its scientific basis. We show how, based on a sequence of uploaded programs, the REMS computer can autonomously decide to switch from NM to the so-called Event Mode (EM) in case an anomalous pattern is detected. When functioning in EM the passage into Sleeping Mode is rescheduled to occur after a configurable amount of time, during which REMS will collect data at the nominal sampling rate.

3 OPPORTUNISTIC SCIENCE ONBOARD MARS ROVERS

3.1 MER/OASIS vs. MSL/REMS

Opportunistic science onboard the Mars Exploration Rover (MER) mission (Spirit and Opportunity) is being implemented at NASA's Jet Propulsion Laboratory (JPL) through a project known as the Onboard Autonomous Science Investigation System, (OASIS). This system identifies opportunistic targets (mainly rock samples), collects data on those targets, then analyzes them onboard to identify those which merit further investigation. It also executes onboard planning and scheduling software that can dynamically modify the projected rover traverse

plan in order to accommodate the new science tasks. Finally, the onboard computer evaluates if sufficient resources are available to meet the additional science requests (Castaño, 2007). Unlike OASIS, the REMS Opportunistic Science computer programs assume a purely passive role in planning and scheduling tasks. The REMS computer executes a sequence of instrument commands that the MSL main computer has uploaded into its flash memory. These are actions that REMS must execute at pre-scheduled times without further intervention by the rover computer – acquisition cycles, parameter configuration, housekeeping, etc. The EFA's are part of the set of programs uploaded into the REMS memory and executed once every session. Their only effect on the sequence of operations is to (eventually) extend the period of data acquisition, considering its previously allocated resources. This framework is designed not to interfere with pre-scheduled regular activities. The approach inevitably limits the scope of REMS Opportunistic Science activities but, on the other hand, improves its degree of autonomy and risk avoidance level.

3.2 Targets for REMS Opportunistic Science

The fast evolving phenomena that we wish to sample normally involve multiple timescales which cannot be fully accommodated within normal session periodicity and/or duration. These are the natural targets for Opportunistic Science actions. They can be effectively classified into i) boundary layer oscillations (BLO's), ii) dust devils and plumes, iii) microfronts, iv) local dust storms, v) orographic winds and vi) mountain waves. An algorithm to detect BLO's must be capable of recognizing fluctuations with timescales ranging from a few minutes to about one hour. Dust devils are much shorter events, generally not exceeding a few minutes. They consist on rotating columns of warm air made visible as sand and dust is sucked into the central core. Usually, convective plumes are even more ephemeral than dust-devils. Plumes are characterized by straight-line winds converging to a hot spot where the warmer air starts to rise. They do not display the rotation of the horizontal wind component that characterizes dust devils; rather, a pronounced increase in the vertical wind component is observed. Microfronts share the structure of their synoptic counterparts but arise on a local scale instead, taking a couple to a few hours to pass over a given point. The evolution of global and regional dust storms can be tracked from measurements in REMS nominal mode. However, data will be way

too sparse to provide an accurate description of short-scale, local events. The low atmospheric density of the martian atmosphere and the intense radiative processes drive robust orographic flows. Furthermore, the patterns of large-scale circulation are reinforced by the extreme regional asymmetries of the Mars elevation field. Sometimes these orographic flows appear associated with periodic buoyancy perturbations which develop when stable stratified air ascends a barrier – mountain waves. Like on Earth, these waves occur on the scale of individual mountains or chains with oscillation periods ranging from a few minutes to one sol.

4 CHANGE DETECTION ALGORITHM

4.1 Principles of EFA Design

Due to their multiple timescales, the above phenomena would be missed or insufficiently sampled should the unit operate always in NM. In the case of phenomena lasting a few dozen minutes to a few hours the measurements at high sampling rate in sequences of short acquisition cycles will mostly produce redundant data whereas the session periodicity is much too low to permit a smooth characterization. For the most brief phenomena, such as plumes and dust devils, the session duration would, in principle, be enough to fully capture the evolution of one or more of these events, and the sampling frequency adequate. However, because the unit will be sleeping for more than 90 % of the time the probability that such an event will fall within the 5 minute allocated slot is small; in most occasions REMS will miss the phenomenon entirely. Indeed, the experience of past missions, particularly Pathfinder, suggests that relying on serendipitous observations is a very poor strategy to detect dust devils. Dedicated campaigns to search for occasional phenomena are envisaged as part of an alternative 'human in the loop' strategy. Nevertheless, because these are, in general, rare events with uncertain periodicity they are difficult to target by measurements to be carried out at pre-selected, fixed times. One may, if the allocated measurement window is too narrow, miss the phenomena altogether. Alternatively, if it is too wide, valuable resources will be wasted. Performing decision-making onboard the rover allows for science goals to be realized under circumstances where a control loop from the ground is not possible because there is

not enough time for scientists to react to changes in data patterns (by organizing dedicated campaigns, for instance). However, the present framework is not designed to replace entirely human decision making but rather to optimize the combined action of human experts and the REMS embedded system. REMS planning and scheduling activities are performed on the ground, by means of the Ground Data System (GDS). The GDS provides all the computational tools required to accomplish these tasks as well as instrument health monitoring and data analysis. An Opportunistic Science Software (OSS) package is integrated in the GDS. Every day, the downloaded REMS data product is processed at the GDS and the part specific to the self-triggering procedure is fed into the OSS. The complete statistics of event detection is recorded for housekeeping, diagnosis and debugging purposes. On a regular basis, analysis of the results will permit fine tuning and in-flight calibration of the EFA's. This procedure will be supervised jointly by scientists and software engineers present at the GDS. The standard operation procedures involve generating activity plans for a few sols determining, whenever possible, if local meteorological events of interest are likely to occur in that period. Having negotiated with the MSL project management the resources for the period being considered, the extra measurement time available is distributed though a number of possible EM windows. These and other relevant parameters are updated at the next Schedule Table Script (ST_Script) uplink. The REMS computer system is then left to decide autonomously whether or not to switch into EM according to the disposition of allocated windows and the output of the EFA's.

4.2 Design Flexibility

The above framework requires an onboard software design capable of offering full flexibility as the process of calibration of the EFA's will continue on Earth during the MSL cruise phase. Design flexibility is also important so that diagnosis, fine-tuning and debugging of the EFA's are possible after operations begin on martian surface, with minimal resort to software patching. It is also expected to reduce substantially the risks to baseline operation associated with the relative increase in software complexity which the Opportunistic Science capability inevitably carries. The current design rationale is as follows: at the end of a measuring session the REMS micro-controller will run a prescribed sequence of EFA's. The order in which the EFA's on the list are executed can be modified at every ST_Script update. The first step in

any EFA is to process sensor raw data by applying *estimators* to compute *observables*. The latter emulate as close as possible the behavior of the actual physical parameters (e.g. temperature, pressure, wind magnitudes and direction, etc.). Estimators are thus simple procedures that involve functions and coefficients determined during the sensor's calibration. The reliability of observables as proxy values is assessed through comparison with the output of the GDS post-processing software that retrieves the 'true' physical parameters from raw data. Each EFA is divided in two parts running sequentially: detection and validation. Only validated detections will cause REMS to self-trigger into EM. The detection part of the EFA reads the relevant observables and, through a sequence of logical operations decides whether or not a detection has taken place. Then it assigns an initial confidence level to that detection, called the Baseline Confidence Level (BCL) to be compared with the uploaded Threshold Confidence Level (TCL); if $BCL > TCL$, the detection is validated: the EFA will immediately stop running, all subsequent EFA's on the list will be overruled and the unit will shift into EM at once. If at least one detection has occurred but nevertheless had been assigned a BCL value below threshold, then the EFA will compute a number of flags and/or consult a table of previously set flags. The final result of these computations is an integer value, called the Increase in Confidence Level (ICL), incremental to the BCL. Both intervene to calculate the final Detection Confidence Level (DCL). If $DCL > TCL$, then EM is triggered. Flags are encoded signals either internally generated by the EFA acting on observables or historic records, or engendered at the GDS. In the later case, the flags are generated by the OSS package and uploaded as parameters in the ST_Script. Flags have limited resolution (small integers and binary numbers) and intervene only at the validation stage. For instance, the orography flag may take up to 16 integer values representing a type of orographic feature – crater rim, mountain ridge, rock, etc. – a scale of elevation with respect to rover position and the feature's size. Internal generation of flags, within the EFA, will sometimes involve elementary statistical analysis while in other cases it implicates logical operations and/or Lookup Table (LUT) consultation. For instance, in the EFA for microfronts described in the next section, the PLO flag – for 'Pressure Low' – indicates, based on the history of measurements performed in past sessions, whether a sustained pressure decrease in the hours preceding the passage of a cold front has occurred. When no detection has taken place, or achieved the TCL required for validation, the system proceeds to execute the next EFA on the list. If, once all the EFA's on the list

have been executed, no detection occurred or was validated, the unit will continue its scheduled operations normally, going into sleeping mode at the pre-scheduled time. REMS will keep in memory the session averages of the observables as well as a history of the parameters involved in the EFA's, such as confidence levels, flags, etc. Normally, data for a complete sol should be kept but this may vary depending on total memory load.

4.3 Two-tier Example Algorithm

We provide an example of EFA structure in Figure 2 using a simplified flow-chart. The example EFA considered here targets microfronts. It is a Multiple-Session Detection Algorithm (MSDA), *i.e.* entails accessing data from more than one session. Note also that it requires detrending, *i.e.* the deviations with respect to the foreseeable trend have to be calculated in the beginning of the algorithm. A first level detection, L1, results from a qualitative divergence with respect to the trend, when temperature rises in late afternoon or drops before its normal apex, for instance. The persistence of this inversion for a number of consecutive sessions is interpreted as a sign of confidence build up, and thus the Baseline Confidence Level (BCL) is set accordingly. A second detection level, L2, is based on quantitative divergence only. Even in the case when the sign of temperature variation is the one expected, there still may be a discrepancy in its quantitative rate-of-change (ROC). For instance, the ROC value may exceed some threshold d above the expected temperature progression. As this condition is obviously weaker than trend inversion it shall be assigned a lower BCL. If the relevant BCL is lower than the threshold, then the EFA will proceed to compute flags – in this case the PLO flag mentioned above and also two other flags signaling, respectively, an increase in wind magnitude (WIM) and the persistence in direction (DIR) of the wind vector. Depending on their values, the DCL's may or may not be increased, as previously described.

5 FUNCTIONALITY TESTS AND CALIBRATION

5.1 Overview of the Procedure

Functionality tests and calibration of the EFA's will be carried out on a desktop computer emulation using selected signatures of the events as input. These test signatures can be created from: i) real

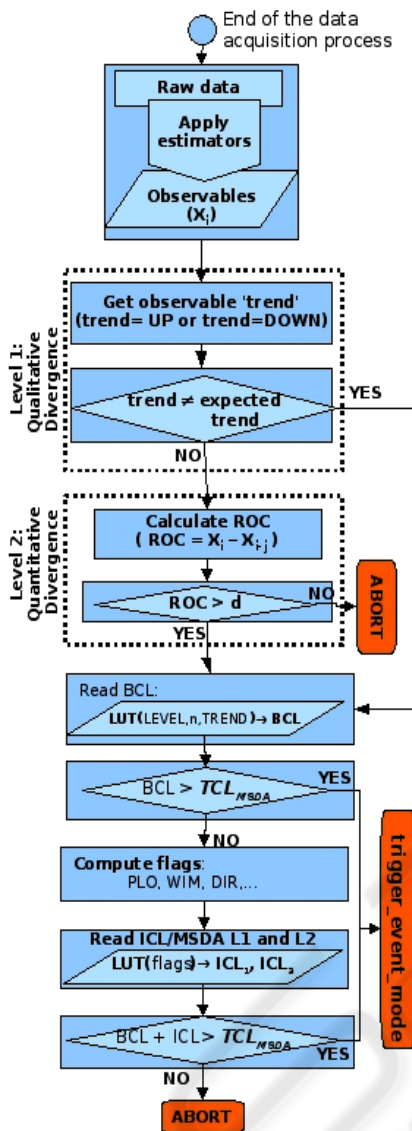

Figure 2: An example EFA flow-chart.

Martian weather data ii) output of mesoscale models ii) meteorological data from martian environmental analogues iii) engineered representative datasets and iv) field tests. Upon application of the fine-tuning procedure the percentage of false positives and false negatives is evaluated and once their numbers lie within acceptable levels the EFA is considered calibrated.

5.2 Martian Weather Data

Up until now only the Viking and Pathfinder missions have carried out successful meteorological experiments on the surface of Mars. The Phoenix lander - currently in its cruise phase and due to land

on May 25, 2008 – carries temperature and pressure sensors together with wind speed and direction indicators. Currently we are working with data from Viking and Pathfinder and, if Phoenix is successful, we shall use its data as well. Each of those datasets has its merits and faults: the Viking data have poor resolution but is extensive; Pathfinder data cover a much shorter period but display higher resolution. In the later case, in addition to signatures of dust devils registered by the sensors, there are, in some cases, simultaneous confirmation from images. We shall apply the EFA's to selected parts of the time series chosen because they reveal the characteristics of a given event, with particular focus on the patterns already presented in the scientific literature as symptomatic of the phenomena under scrutiny. After a number of refinement stages we expect to reach the minimal algorithmic complexity required to detect the relevant features.

5.3 Martian Environmental Analogues and Field Tests

Because weather data from Mars is scarce we will have to use data from martian environmental analogues and field tests on Earth. Overall, the best candidates for the role of environmental analogues are the dry valleys of Antarctica, because of the extremely cold and dry air and the fact that a fairly predictable regime of robust slope winds exists. When searching for dust devils and plumes the best places to look for on Earth are deserts. These phenomena have been extensively studied in the Arizona desert (Renno, 2004). It is an unfortunate yet unavoidable fact that the optimal locations to conduct field tests are harsh environments in remote areas of difficult (and thus expensive) access. This fact poses a constrain in our current development of a priority list for site selection for field tests. The sites being evaluated include Deception Island – home to a Spanish Antarctic base, where members of the REMS team regularly conduct research – as well as sites in the Atlas mountains and the Atacama desert. Nevertheless, locations in close reach of the CAB facilities will be favored, at least in the preparatory phases of the field test campaign. In this vein, we are currently assessing the reliability of certain arid and semi-arid regions in the Iberian peninsula as partial analogues. A first set of tests will be conducted with a commercial weather station. In a later stage, we shall use a REMS model, complete with rover mast and deck dummies, to carry out end-to-end performance and reliability tests of the EFA's under the geometrical constraints imposed by integration with the rover.

5.4 Engineered Artificial Datasets

In order to overcome the difficulties of using terrestrial data in calibration, due to dissimilarities between the atmospheres of the two planets, we shall work also with engineered data. Based on the analysis of field data and sensor calibration data obtained under martian conditions, we shall create artificial datasets to mimic the signatures expected from the phenomena. Integrating sensor calibration data with theoretical models and/or computer simulations, notably mesoscale models of the atmosphere, we can also create prototype signatures that minimize the constraints set by wind tunnels and martian atmosphere simulation chambers.

6 ANTICIPATION

We have outlined a strategy to enable autonomous decision-making aboard a mobile robotic surface probe, in order to optimize its science return. Provided with this capability, REMS will be able to detect sudden and unexpected changes in environmental parameters adjusting its operation mode in response, without the need for a control loop from Earth. As planetary exploration stretches out further away from the Earth, communication delays and interruptions will make remote control increasingly harder. Though in the case of flyby and orbital missions these delays can be accommodated without much hindrance the situation is very different for robotic probes evolving in a changing environment. For a vehicle exploring Titan's surface or Europa's putative ocean, onboard intelligent systems will be essential for virtually all craft operations including guidance and steering, obstacle avoidance, selection of scientific targets, data downlink management, etc. Sending probes to land on these far away bodies is not envisaged in the near future. Until then, the surface of Mars will be the cutting-edge operation scenario and the most demanding testing ground for the implementation of autonomous decision-making in the context of planetary exploration by robots. Inspired by the OASIS concept (<http://ml.jpl.nasa.gov/oasis/>), we decided to use REMS for an experimentation in Opportunistic Science. However, because the processing power of the REMS computer system is low, (even when compared to common household appliances), we are forced to use exceedingly simple programs whose ability to identify changes in environmental conditions cannot be guaranteed *a priori*. But even if some of the concepts being

developed do not mature fast enough to be implemented in REMS/MSL, they still may find application in future missions, to Mars and beyond. Because operational autonomy is intrinsic to the REMS design, the software under development needs not to be integrated with the spacecraft's flight software, and thus the employment of an upgraded version in future missions should be straightforward. This tempts us to anticipate a bold strategy. Indeed, one can envisage a scenario in which future landers and rovers being sent to Mars would each carry a station similar to REMS, provided with autonomous decision-making abilities. Thus, even after every other component of the mission has reached its end-of-life the spacecraft would not turn into waste but instead become a node in an ad-hoc network of weather stations. Of course, each future autonomous station would need dedicated power and data downlink systems; and would have to operate at a low sampling rate and use recurrent transfer windows in order to lower its power consumption and step-up the probability that the data streams be received unbroken by a (future) small network of low-orbit communication relay satellites. This network could be considered either as a precursor mission or a scalable inexpensive alternative to the MetNet mission (<http://www.ava.fmi.fi/metnet-portal/>), currently being proposed, and also NetLander (<http://smc.cnes.fr/NETLANDER/>), abandoned in 2003.

REFERENCES

- R. Castaño et al., *Journal of Field Robotics*, 24 (5), 379-397, 2007.
- N. Renno et al, *Journal of Geophysical Research*, 109, E07001, 2004.