

BIOSIGNAL ACQUISITION DEVICE

A Novel Topology for Wearable Signal Acquisition Devices

Luca Maggi, Luca Piccini, Sergio Parini, Giuseppe Andreoni
Dipartimento di Bioingegneria of Politecnico di Milano - Milan, Italy

Guido Panfili

SXT – Sistemi per telemedicina srl. – Lecco, Italy

Keywords: Wearable device, Brain Computer Interface, Amplifier, Signal Conditioning, Offset Recovery, Low Voltage Amplifier, Band Pass Filtering, ECG amplifier, EEG amplifier.

Abstract: The here presented work illustrates a novel circuit topology for the conditioning of biomedical signals. The system is composed of an amplification chain and relies on a double feedback path which assures the stability of the system, regardless of the amplification block gain and the order of the low-pass filter settings. During the normal operation, the offset recovery circuit has a linear transfer function, when it detects a saturation of the amplifier, it automatically switches to the fast recovery mode and restores the baseline in few milliseconds. The proposed configuration has been developed in order to make wearable biosignal acquisition devices more robust, simpler and smaller. Thanks to the used AC coupling method, very low high-pass cut-off frequencies, can be achieved even using small valued passive components with advantages in terms of circuit bulkiness. The noise rejection filter between the pre-amplification and the amplification stages eliminates the out-of-band noise before the amplification reducing the possibility of having clipping noise and minimizing the dynamic power consumption. The presented topology is currently used in a prototypal EEG acquisition device in a Brain Computer Interface (BCI) system, and in a commercial polygraph which will be soon certificated for clinical use.

1 INTRODUCTION

Wearable systems ought to be totally unobtrusive devices that allow physicians to overcome the limitations of standard ambulatory technology, aiming at providing a response to the need for monitoring individuals over weeks or even months without or limiting their usual behaviour. Such a systems typically rely on wireless, miniature sensors embedded in patches, bandages, or in items that can be worn, such as a ring or a shirt. They take advantage of hand-held units to temporarily store physiological data, which can be uploaded periodically to a database server through a wireless LAN or different gateways that allow Internet connection. The data sets recorded using these systems are then processed to detect events able to indicate a possible worsening of the patient's clinical situation or providing information explored to assess the impact of clinical interventions (Park, 2003).

Wearable devices are usually battery powered: low voltage supply and low power consumption are mandatory features for this kind of devices, in order to provide a good battery life to dimension ratio. In the last 10 years many garments with embedded sensors have been developed: the intrinsic characteristics of such electrodes and the possible instability of the contact make the design of wearable acquisition devices more difficult (Webster, 1991). The main aspects we have to take into account in the design of a wearable surface biopotential amplifier (e.g. Electrocardiogram-ECG, Electroencephalogram-EEG and Electromiogram-EMG) are:

- Dynamic reserve;
- Max offset rejection;
- Fast recovery from artefacts.

Although the operational amplifiers production technology has developed several low power and low cost devices, the development of dedicated

topologies is still necessary in order to maximize the overall circuit performance.

2 METHODS

2.1 Background

Figure 1 shows a typical, state of the art biosignal detection circuit which is composed of a set of independent stages connected in a chain. At the beginning there is a pre-filtering stage, the pre-amplification stage which is followed by the offset rejection circuit and by an amplification and filtering circuit.

This kind of solution is simple and effective when the wide power supply range provides a high dynamic reserve (avoiding clipping problems) and when the mechanical specifications allow the use of high capacity capacitor or the specific application doesn't require very low frequency high pass filter. It is worth to underline that the maximum tolerable offset is given by the following equation:

$$V_{Off}^{MAX} \cong \frac{1}{2} * \frac{(V_{sup}^+ - V_{sup}^-)}{G_{preamp}} \quad (1)$$

Where V_{sup} are the value of the supply rails and G_{preamp} is the gain of the preamplification stage. It is worth noting that in case of a change in the input signal that causes the amplifier saturation, the output of the system will remain latched for a time which depends on the signal amplitude; it is possible to overcome this limitation by increasing the system complexity and inserting a baseline reset circuit

which is activated by the saturation of the system itself.

2.2 General Description

The proposed system is composed of a differential pre-amplification stage P(s): usually realized using an Instrumentation Amplifier (INA). The F(s) block is a unity gain inverting filter (low-pass or low-pass plus notch filter) of any order. A(s) is an amplification stage, while I(s) is an offset compensation network. In the proposed version it is a non-linear circuit which acts as an attenuated inverting integrator when the V_{in} is inside the linear region and as an amplified inverting integrator when the signal is over threshold whose behaviour can be expressed as follow:

$$I = \begin{cases} -\frac{1}{a} \frac{1}{sRC} & \text{if } V_{sup}^- + Th < V_{in} < V_{sup}^+ - Th \\ -k \frac{1}{sRC} & \text{otherwise} \end{cases} \quad (2)$$

where Th is threshold value which identifies a saturated state, 'a' is an attenuation factor and 'k' the amplification factor.

The small signal transfer function and the G_{Loop} of the system are represented by the following equation:

$$TF(s) = P(s) \cdot \frac{F(s)A(s)}{1 - I(s)A(s)[F(s) - 1]} \quad (3)$$

$$G_{LOOP} = A(s)I(s)[1 - F(s)]$$

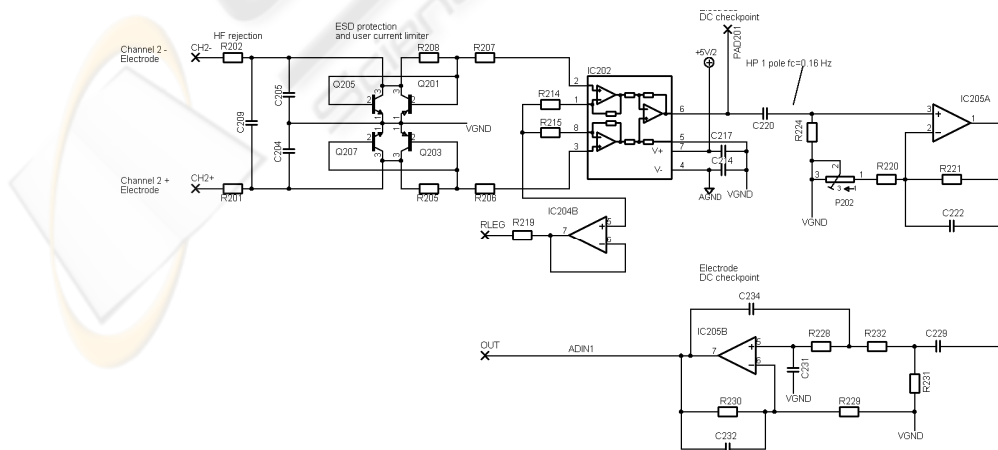

Figure 1: The amplification chain proposed by the OpenEEG project.

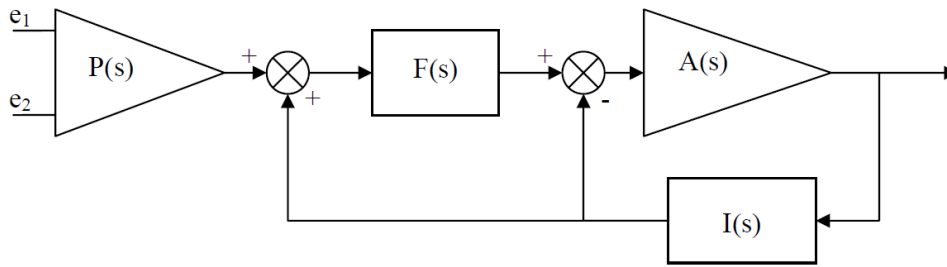

Figure 2: Block structure of the system.

considering that $I(s)$ and $F(s)$ are inverting the equation can be expressed as follows:

$$TF(s) = P(s) \cdot \frac{F(s)A(s)}{1 - |I(s)| \cdot A(s) \cdot [|F(s)| + 1]} \quad (4)$$

$$G_{LOOP} = -|A(s)| \cdot |I(s)| \cdot [|F(s)| + 1]$$

The transfer function is a band-pass amplifier with a single pole high-pass and a low-pass whose shape depends on $F(s)$. Figure 3 shows the bode diagram of a system with the following characteristics:

- $F(s)$: 2nd order low pass at 75Hz;
- $A(s)$: amplifier gain 100 V/V;
- $P(s)$: pre-amplifier gain 5V/V;
- $I(s)$: integrator $1/100 * 1/s$.

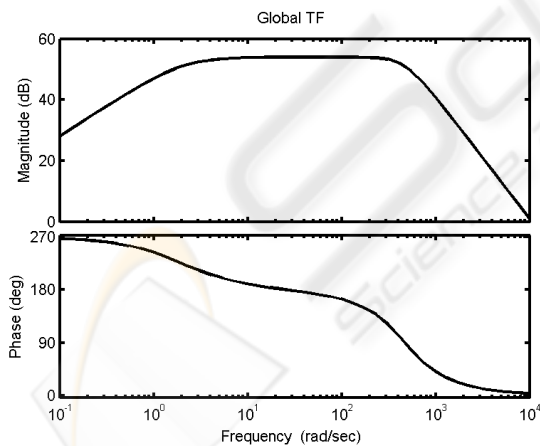

Figure 3: Frequency response of a sistem with 500V/V gain and a 2nd order low pass 75Hz filter.

2.3 Offset Compensation Issues

On the basis of the final output, the offset compensation value is fed both directly to the preamplifier $P(s)$ reference pin, and by modifying polarization of the amplifier $A(s)$. The proposed

structure introduces a systemic offset compensation method which ensures that, thanks to the double feedback path, even when the pre-amplification output is close to the power supply rail, the following stages work inside the linear region this property doubles the maximum tolerable offset:

$$V_{Off}^{MAX} \cong \frac{(V_{sup}^+ - V_{sup}^-)}{G_{pream}} \quad (5)$$

Thanks to this improvement it is possible to increase the gain of the pre-amplification stage taking major advantages of the qualities of the INA in terms of CMRR a noise figure.

As proposed in our previous work, the AC-coupling of the amplifier using a feedback integrator allows the tuning of the high-pass pole frequency just by varying the open loop gain of the system (Maggi, 2004). When setting the parameters for biosignals acquisition, it is useful to insert an attenuation factor in the $I(s)$ block in order to compensate the amplifier gain: keeping the G_{loop} below the unity gain the high pass pole is moved to the lower frequencies.

The $I(s)$ automatically identifies a saturation of the amplifier using a threshold method: if the value is outside a predefined interval, the attenuated integrator is switched into an amplified integrator that quickly brings the system output inside the linear interval.

The k value defines the delay of the offset recovery of the system: for example we can have a 0.05Hz high pass pole during the linear phase and switch it to a 100Hz one during the offset recovery phase, achieving a baseline recovery in about 10ms.

2.4 Stability of the Loop

During the normal operation the G_{loop} is usually kept low using the attenuation net of $I(s)$ in order to achieve the desired high-pass frequency; when the

saturation occurs the $I(s)$ is switched to a high gain configuration: in this section the stability of this configuration will be discussed both by considering the Bode Stability Criterion and the root-locus method.

2.4.1 Bode Stability Criterion

Provided that $A(s)$ have a sufficient bandwidth to be considered like an ideal amplifier and that $F(s)$ and $I(s)$ are stable, the poles in $F(s)$ and $I(s)$ are the possible instability causes of the system. Considering the open-loop transfer function, the $I(s)$ provides a single pole at low frequencies, while the $F(s)$ put a variable number of poles at the higher bandwidth limit. Thanks to the second feedback path the poles of $F(s)$ are compensated by the same number of zeroes. The figure 4 shows the Bode diagram of the original $F(s)$ and the compensated one.

The newly created zeroes must be very close to the $F(s)$ poles in order to allow a difference between the DC gain and the high frequency one of just 6dB. The nearness of poles and zeroes makes the phase plot very flat: for any complexity of the filter the plot is between +90 and +270 degrees.

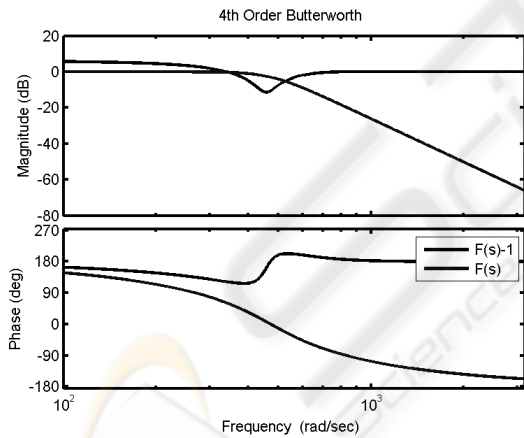

Figure 4: Bode plot of the compensate filter against the original one.

Figure 5 shows the phase diagram of the resulting G_{loop} , including the pole introduced by the integration process, it is possible to notice that it never cross the instability region.

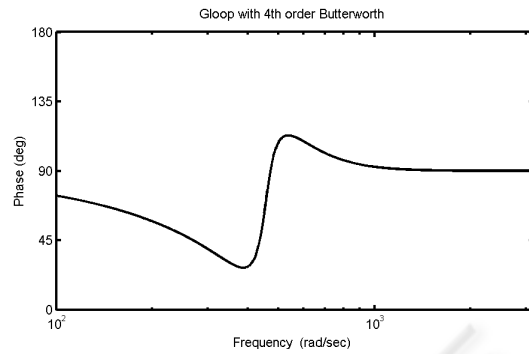

Figure 5: Phase diagram of the resulting Gloop.

2.4.2 Root Locus Study

The root locus (figure 6 and 7) show that the all the resulting closed loop poles are in the left semi-plane even with a 9th order low pass filter. For the higher open loop gains the phase margin can be less than 45 degrees, but during the nonlinear phase the overshoot can make the settling faster.

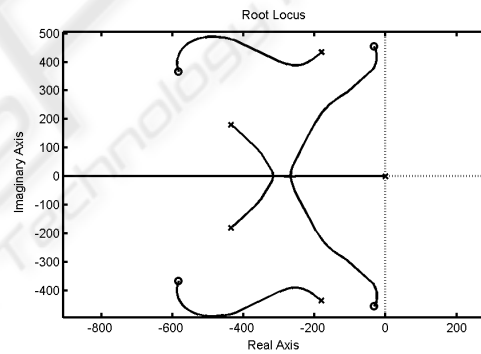

Figure 6: Root locus of a 4th order system.

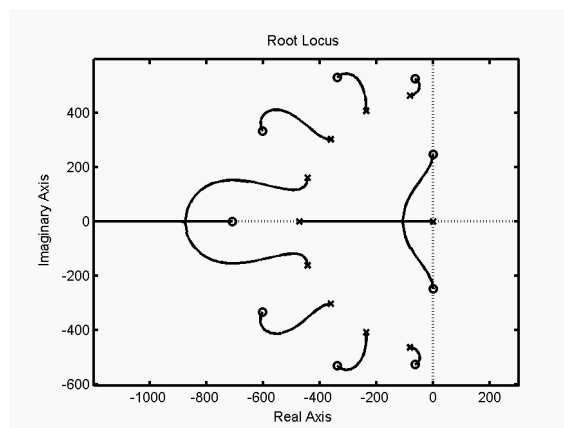

Figure 7: Root a 9th order filter system.

3 RESULTS

The configuration has been adopted both in a commercial wearable polygraph, in order to acquire the ECG signal and on a EEG acquisition prototype devoted to Brain Computer Interface applications. Figure 8 shows the proposed implementation for the EEG acquisition device. The system is 3,3V single supply powered using a li-ion battery and a low-dropout linear voltage regulator. The preamplification stage has a gain of 100V/V and P(s) is realized using a INA118 (Texas Instruments). The other four operational amplifiers are contained in a single integrated circuit (TLC2254, Texas Instruments).

The F(s) is an inverting double pole low pass filter, and A(s) is an amplification chain. The I(s) is composed by an attenuation network (R30 and R31), an inverting integrator (IC2B, C1 and R12) and the nonlinear activation network (K2, H2, R22, R23, R25, R27, R26).

The R27 and R26 network are used in order to set the intervention threshold of the offset recovery circuit: when the V_{be} of K2 and H2 are kept below 0,7 Volt the transistor are turned off. The Th parameter is defined also follows:

$$Th = 0,7V \cdot \frac{R27 + R26}{R27} \quad (6)$$

K2 is switched on when the amplifier output voltage reaches the upper saturation limit, while H2 is switched on in case of lower saturation. When one of the transistor is turned on, it injects a current into

the inverting integrator causing the fast offset recovery. R22, R23, R25 are necessary in order to limit the transistor current and avoid instabilities related to 2nd order effects of the components. The final amplification stage is optional and provides a last anti aliasing filtering.

The system circuit has been successfully used in a brain computer interface application (Piccini, 2005 and Maggi, 2006) and has an offset recovery time of less than 10ms.

4 DISCUSSION

The proposed architecture is a smart and cost effective solution to the problems related to the acquisition of biosignal in difficult acquisition situations based on an analog design; thanks to the evolution of modern digital devices, it is possible to adopt other method in order to achieve similar results.

The strength of the proposed topology is that a simple local solution doesn't require a full systemic redesign and support development of modular multiparametric wearable devices.

The discussion doesn't take into account second order effects related the components physical limitations: even if the architecture is robust and the frequency range of biosignals is reduced, the design of an amplifier based on the proposed topology should be approached with care.

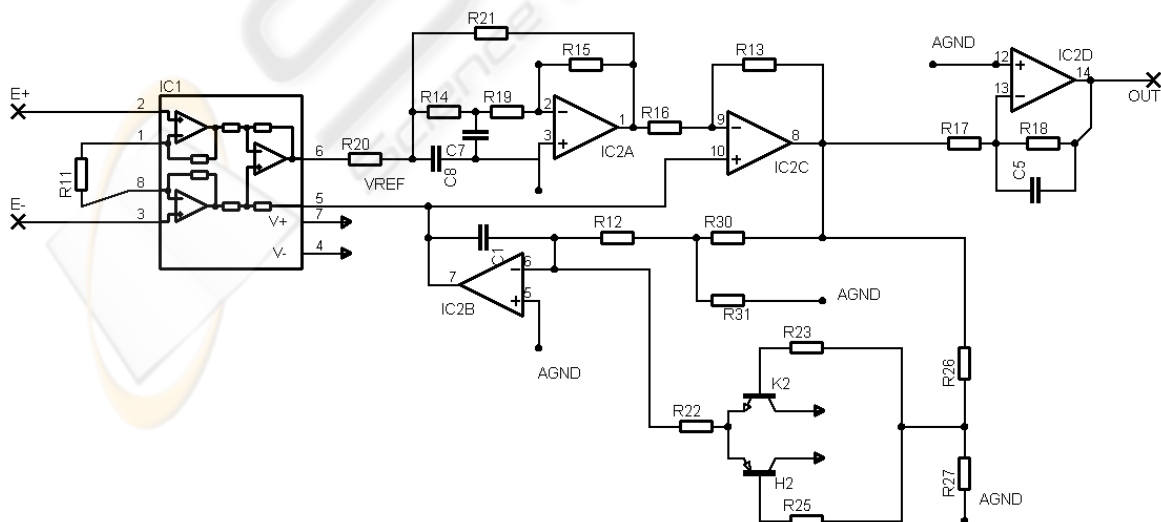

Figure 8: Schematic of the EEG amplification circuit.

5 CONCLUSIONS

The analysis proposed in this paper shows an interesting approach for providing a cost effective solution for AC coupled, low power amplifiers. Although born in a biomedical research laboratory, it faces problems related to a wide range of different applications. Also for this reason, this generic topology has been patented in Italy, and successfully revised by the European Patent Office for the PCT extension.

ACKNOWLEDGEMENTS

This work has been partially supported by ST Microelectronics and IIT Istituto Italiano di Tecnologia.

REFERENCES

- Park, S., Sundaresan, J., 2003. IEEE Engineering in medicine and biology magazine, *Enhancing the quality of life through wearable technology*
- Webster J. G., 1991. Innov. Tech. Biol Med. 12, n°spécial 1, pp. 39-45, *Noise sources in surfaces electrodes*
- L.Maggi, L. Piccini, S. Parini, F. Beverina, S. Silvoni, G. Andreoni, 2004. Biomedizinsche Technik, v.49 pp.69-70, *"A portable electroencephalogram acquisition system dedicated to the brain computer interfaces"*.
- L.Piccini, L.Maggi, S.Parini, G.Andreoni, 2005. Shangai, Proceedings of EMBC. *"A Wearable Home BCI system: preliminary results with SSVEP protocol"*.
- L. Maggi, S. Parini, L.Piccini, G.Panfili and G.Andreoni, 2006. NY, Proceedings of EMBC. *"A four command BCI system based on the SSVEP protocol."*