

Using Environmental Data for IoT Device Energy Harvesting Prediction

Mansour Alzahrani^a, Alex S. Weddell^b and Gary B. Wills^c

School of Electronics and Computer Science, University of Southampton, Southampton, U.K.

Keywords: IoT, Energy Harvesting, Solar Energy Harvesting, Environmental Data, Weather, Machine Learning.

Abstract: There has been significant innovation in the domain of Internet of Things (IoT) as nowadays wireless data transmission is playing an essential role in various organizations like agriculture, defence, transportation, etc. Batteries are the most common option to power wireless devices. However, using batteries to power IoT devices has drawbacks including the cost and disruption of frequent battery replacement, and environmental concerns about battery disposal. Solar energy harvesting is a promising solution for long-term operation applications. However, solar energy harvesting varies drastically over location and time. Due to fluctuating weather conditions and the environmental effects on PV surface condition, output could be reduced and become insufficient. Environmental conditions including temperature, wind, solar irradiance, humidity, tilt angle and the dust accumulated over time on the photovoltaic (PV) module surface affects the amount of energy harvested. To address this issue, a novel solution is required to autonomously predict the harvested energy and plan the IoT device tasks accordingly, to enhance its performance and lifetime. Using Machine Learning (ML) algorithms could make it possible to predict how much energy can be harvested using weather forecast data. This research is ongoing, and aims to apply ML algorithms on historical weather data including environmental factors to generate solar energy predictions for IoT device energy budget planning.

1 INTRODUCTION

It is estimated by Arm that about 1 trillion devices will be connected and become part of everyday life by the year 2035 (Sparks, 2017). The Internet of Things (IoT) has the potential to make our surroundings, houses, and vehicles smarter and more quantifiable (Loh, 2021). Moreover, IoT devices such as sensors, lights, and meters provide data and information to smart cities for collection and analysis. This data can be used to improve services, infrastructure, utilities, and other aspects of life (Gyrd, 2018).

A sensory IoT node consists of sensors, a processor, a transceiver, and a power supply. Batteries are the most common source of energy used to supply power to wireless IoT nodes, which can either be recharged or replaced according to the installation conditions (Tong, 2011). Batteries are often the largest part of an IoT device and, in most cases, will need to be replaced during the system lifetime—however, the cost of replacing batteries is

frequently higher than the cost of the IoT device itself. Owing to cost and environmental concerns, some systems now use alternative energy supplies which can exploit ambient energy (Khan, 2015). Energy can be harvested from various renewable and ambient energy resources, for example, vibration/movement, wind, solar, heat, or radio frequency waves (Garg, 2017). Powering IoT devices through harvesting sustainable energy has proved to be an effective solution, extending their operation lifetime and simplifying their installation. Solar energy has gained more attention due to the availability of light in many applications, along with its simplicity and low component cost. However, solar energy harvesting depends on the site's conditions, such as geographical location, weather, solar irradiance, temperature, and solar angle. The output power of PV panels is dependent on the solar irradiance. However, PV efficiency is indirectly related to the other parameters, including relative humidity, dust accumulation, wind speed, and temperature (Yang, 2014). Dust accumulation on the

^a <https://orcid.org/0000-0002-0458-773X>

^b <https://orcid.org/0000-0002-6763-5460>

^c <https://orcid.org/0000-0001-5771-4088>

surface causes shading, and hence performance degradation. A sequence of rain and sandstorms affects the adhesion of dust on the surface. We need to be able to understand the complex environmental conditions which affect the solar energy harvested. Recently, much work has been done on power forecasting and analyses of PVs. Different models have been used for predictive analyses. Statistical and machine learning (ML) models may give an insight into the features of data dependencies and illustrate the importance of individual characteristics (Bergonzini, 2009).

This research aims to investigate the feasibility of using ML and environmental data for solar energy prediction, to increase system performance. It will focus on predicting the amount of energy available in the future, based on historical data and future public weather forecasts. This paper gives a brief background to IoT devices and energy harvesting, focussing on the environmental impact on solar energy harvesting and discusses some prediction algorithms (section 2). Next, model design (section 3) gives an overview of the proposed solar energy prediction model components and workflow, including a description of the data acquisition needed for the model. Lastly, section 4 provides details of future work.

2 RESEARCH BACKGROUND

2.1 Wireless IoT Devices

Wireless smart sensors are becoming more critical in the development of the Internet of Things. These smart devices are aimed to measure and monitor natural conditions like temperature, dampness, sound, pressure, air quality (Newell, 2019). A major complication for such smart IoT devices being genuinely ubiquitous is their requirement for a long-term, dependable power supply. Batteries are the most common option to power wireless devices. Still, they must be replaced regularly to guarantee continued functioning. Such a requirement is unattractive since it implies significant maintenance expenses, particularly in distant locations. Energy harvesting from solar, wind, thermal, and RF sources has been suggested to solve these issues (Khan, 2015).

2.2 Solar Energy for Wireless IoT Devices

Photovoltaic (PV) cells convert light energy to electricity. Solar is one of the most promising and

prevalent forms of renewable energy that utilizes either natural or artificial light to generate electricity (Piñuela, 2013). Solar energy harvesting enables the operation of IoT nodes sustainably and can simplify their deployment. PV energy harvesting, unlike other harvesting sources such as temperature difference, vibration or airflow, is widely available in sufficient quantities to make the powering of low-power IoT devices practical.

As solar energy harvesting varies significantly over time, the energy collected must sometimes be stored to be utilized when the energy source dictates. As a result, the Harvest-Store-Use method is well suited to dealing with unstable energy sources (Choudhary, 2020).

2.3 Environmental Impact on Solar Energy Harvesting for Wireless IoT Devices

Solar energy fluctuations are determined by seasonal climatic and weather variables such as temperature, hourly solar angle, solar irradiance, the orientation of the solar panel and tilt angle and shadows (Yadav, 2014). The following sub-sections will explore the literature on the impact of various environmental factors on PV module performance.

2.3.1 Effect of Temperature on PV Module Performance

Around 17-20% of solar energy is converted into electricity by a PV module. However, some of the wasted solar energy appears as heat. The increase in temperature of the PV module has negative impact on its efficiency. The electrical yield is reduced with an increase in the temperature of the module (Rahman, 2017). According to D. Du, the efficiency of crystalline silicon PV cell drops around 0.45%/°C (Du, 2013). In an area with an irradiation level of 1000 W/m², the PV temperature increased to around 56 °C, causing the module output power dropped to from 49.89 W to 29.42 W and the electrical efficiency decrease 3.13% (Rahman, 2015), furthermore at around 25 °C ambient temperature is the maximum PV efficiency can be achieved. The temperature of a PV module can be calculated by this equation:

$$T_c = T_{amb} + (NOCT - 20) G / 800 \quad (1)$$

Where,

T_c : Cell temperature

T_{amb} : ambient temperature

(NOCT): The normal operating cell temperature

G: Irradiance

2.3.2 Effect of Dust Accumulation and Tilt Angle on PV Module Performance

The capability of the cover glass on the surface of the solar cell module to transmit the solar light has a significant impact on the solar panel's performance. Over time, the transmittance may decrease due to dust accumulation on the glass, which depends on the collection of dust on the panel surface (Sarver, 2013). After six months of deployment in the Kingdom of Saudi Arabia (KSA) environment, PV module harvested power decrease by 50% (Adinoyi, 2013); furthermore, the power outputs decreased by 20% after one sandstorm. The dust accumulation on the surface of the solar PV panel causes the short circuit current to drop off at a faster rate, mainly when the density of dust is higher. There is a 1.7 % loss in PV power per g/m² when dust accumulates on the surface of the PV. Both outdoor and indoor circumstances were validated for this correlation (Dhaundiyal, 2020).

In dusty environments, the tilt angle also has an impact on dust accumulation. The deposition of dust particles on the PV surface with tilt angle was studied by Sayigh et al. (Sayigh, 1985), who experimented in Kuwait City. Exposing the panels outside for 38 days, Sayigh and his team observed that 17% to 64% of plate transmittance is reduced when the tilt angle is changed from 60° to 0°, respectively. Another study shows that, after exposing the PV panels outside for 14 days, results reported the efficiency dropped by 37.63%, 14.11%, and 10.95% for the 0°, 25°, and 45° tilt angle, respectively (Hachicha, 2019).

2.3.3 Effect of Wind Speed and Direction on PV Module Performance

The dissipation of convective heat transmission of the solar module is enhanced by air flow, hence lowering the temperature of the panel and helps to sustain the conversion performance (Mazón, 2011). In Dhahran, KSA, for example, the module's temperature is reduced by around 10 °C by the increase in velocity of wind from 2.8 to 5.3 m/s (Said, 2015). Several experiments were held, artificially varying the wind direction and velocity to examine the performance of solar PV. Dust particles are blown away from the surface of solar PV by the wind, diminishing dust deposition. In Egypt, it is seen that after two weeks of wind, the rate of dust deposition on a PV panel surface decreased significantly (Hegazy, 2001). However, the impact of wind direction is not appropriately addressed. Wind coming from the desert should be warmer than from the sea or

lakeside. Hence the direction wind also plays a significant role in the temperature of the PV module.

2.3.4 Effect of Humidity on PV Module Performance

It is observed that the solar PV efficiency is increased when humidity is relatively low. The impact on the performance of solar modules due to relative humidity has been verified. The performance yield of solar cells is enhanced from 9.7% to 12.04% at 60% to 48% humidity, respectively (Katkar, 2011). As far as power is concerned, it is noted that with the increase in relative humidity by 20% in result approximately 12.4% of power is decreased (Rahman, 2015). Concerning dust adhesion and humidity, it is noticed that dust particles stick on the panel surface due to humidity. In order to restore the module to its initial power efficiency, cleaning the PV module's surface is required. In respect of quantitative analysis, it is seen that adhesion is increased by approximately 80% when relative humidity is increased from 40% to 80% (Said, 2014).

2.3.5 Effect of Rainfall on PV Module Performance

Rainfall has an impact on solar PV, as rain removes dense dust from the panels. However, some particles of dust stick on the panel surface due to cementation and might not be detached. Michel and Muller (Micheli, 2017) have shown the correlation between surface cleaning and a rain event. However, a minimum of precipitated water is required for effective cleaning. Different reports provide the minimum rain threshold required for cleaning the panel, such as minimal of 5mm daily rainfall (García, 2011) and 6.9mm (Toth, 2020). The intricacy of the surface cleaning can be attributable to the multiplicity of threshold conditions because they are further subject to different factors such as dust type, wettability, speed of droplet, dust adhesion, and surface inclination state (Ilse, 2018). In dry and semi-dry regions, where the soiling rate is high and there is less rainfall, rainfall is not considered sufficient for dust removal. In such areas, a proper cleaning mechanism is required for better performance.

2.3.6 Effect of Air Quality on PV Module Performance

Air quality is an important parameter, since the accumulation of ambient Particulate Matter (PM) on the surface is the main reason for PV soiling. Furthermore, soiling on the PV surface has an impact

on the Direct Normal Irradiance (DNI); hence the PV model performance will be decreased. PM with an aerodynamic diameter of $<10\mu\text{m}$ (PM₁₀) or $<2.5\mu\text{m}$ (PM_{2.5} or PM_{fine}) is the measurement of the air quality. Micheli et al. found that ambient PM₁₀ concentrations yielded better correlation in long dry period than PM_{2.5} concentration (Micheli, 2019). In studies (Micheli, 2019) and (Coello, 2019), it has been shown that PM concentrations variability are important factors in modelling PV soiling. Moreover, air quality has an impact on the horizontal visibility, hence the Global Horizontal Irradiance (GHI) reaching the PV surface is reduced by as much as 40% to 50%, with a much more substantial reduction in the Direct Normal Irradiance (DNI) at noon when the Aerosol Optical Depth (AOD) is 3.0 (Kosmopoulos, 2017). Therefore, air quality is one of the parameters that will be explored and used in developing a predictive PV soiling model based on time-series.

2.4 Prediction Algorithms for Solar Energy Harvesting

In the last couple of years, several prediction techniques have been used to achieve the solar energy prediction. These techniques can be distinguished between Past Predicts the Future (PPF) and Weather Forecast-Based Techniques (Sharma, 2010). PPF techniques consider previously available data on how much energy was harvested and apply that to the future. These techniques divide the day into a number of equal-sized time slots, and the prediction is done either for the next slot based on the previous one or for the same time slot of the next day. These are simple techniques and easy to use but fail to give valuable predictions when the weather changes.

Exponentially Weighted Moving Average (EWMA) is an algorithm that was proposed by Kansall et al; the algorithm has shown good predictions accuracy results (Kansal, 2007). However, the EWMA prediction accuracy is high only when weather conditions are consistent. The reason for this is because of the way the EWMA works. The EWMA algorithm divides the day into a number of fixed time slots. Moreover, it predicts the energy harvesting rate based on the weighted average for that period in previous days. When the weather changes frequently, and there is a mix of sunny and cloudy periods, the EWMA algorithm gives low accuracy predictions.

Piorno et al. proposed the Weather-Conditions Moving Average (WCMA) algorithm to solve these shortcomings of the EWMA (Piorno, 2009). It includes a GAP factor, which is supposed to take into account the average harvesting of previous days and

compare it to actual harvesting, thus determining the weather direction change and considering it in the prediction. While this does make better predictions compared to EWMA, once again, when weather changes are more frequent, and the fluctuations are significantly larger, so are the predicting errors. These predictions techniques are based on historical data, i.e. how much energy was harvested in the past. Nevertheless, this historical approach is unreliable when weather changes occur between days and even during a single day. To be able to make better energy harvesting predictions and to overcome the limitations of the PPF techniques, such as their short-term focus, weather forecasts need to be included. Weather forecasting has been used with historical data to provide better predictions of future energy harvesting. A study by (Sharma, 2010) revealed that weather forecast-based predictions give better results compared to PPF.

The Artificial Neural Network (ANN) and Support Vector Machine (SVM) is widely used forecasting techniques for forecasting the nonlinear time series data. SVM used for the prediction of daily and monthly global solar radiation in (Belaid, 2016) proved to require few simple parameters to get good accuracy. The energy predictions can be enhanced through techniques that allow several profiles to be combined. The machine learning approach will be applied on automatic learning and improve the prediction.

3 SOLAR ENERGY PREDICTION MODEL BASED ON WEATHER DATA FOR SOLAR ENERGY HARVESTING WIRELESS IOT NODES

A solar energy prediction model will allow IoT nodes to schedule their duty cycles and tasks based on predicted energy. The goal of the proposed model (data-driven approach) is to explore the machine learning algorithms and the associated feature extraction for better solar energy predictions. Knowing the solar energy budget ahead of time and planning the sensor node tasks accordingly, will aid the sustainable operation of the sensor node.

3.1 Overview of the Solar Energy Prediction Model

The proposed model has multiple data inputs and prediction models (See Figure 1).

Data Acquisition is the key to accurate power prediction. This subsection discusses and describes the required data for machine learning which will serve the proposed model in this research.

Historical Weather Data

The data collected is of two different types. The first data is from King Abdullah City for Atomic and Renewable Energy (K.A. CARE) for Jeddah City, hourly data from June 2017 - June 2020. This data consists of various variables such as air temperature, global horizontal irradiance, wind direction, moisture, and zenith angle, etc (See Table 1). The second data set is from openweathermap.org for the same period as the first data set. This data consists of various variables such as visibility, clouds, dewpoint, rain, time of sunrise, and sunset (See Table 2). The two data sets will be combined and used to train and test the prediction model. Dust Accumulation, Air Quality, and Horizontal visibility are some of the focuses of this research. Hence, they will be investigated further, and the results added to the model to enhance the prediction.

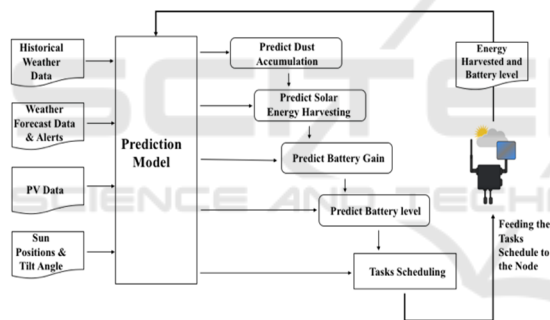

Figure 1: The Proposed Solar Energy Prediction Model.

Weather Forecast Data

The weather forecast data will be gathered from openweathermap.org via their accessible API (Openweathermap.org, 2022). This forecast data is hourly. As part of the data preparation, the coldness levels need to be changed to numerical values.

Photovoltaic Data

This data includes PV size, efficiency, peak power point current and voltage, tilt angle, and orientation.

Energy Data from Sensor Node

- **Battery Level:** The battery level (state-of-charge, SoC) can be estimated based on the battery voltage measurement. The battery level will be presented as

a percentage from (0 - 100 %) based on the battery voltage measurement and the energy storage properties. This data will be gathered for each time slot from the sensor node.

- **Solar Energy Harvested:** The amount of energy harvested will be calculated based on the measurement of the current from the solar panel, considering the charging state. Knowing the charging state is essential for the machine learning algorithms.

Sun Position and Tilt Angle

The sun position will be calculated hourly based on the location of the sensor, time of the day, azimuth, and zenith. The PV tilt angle and the orientation are important for calculating the incidence angle based on the sun's position. The amount of solar irradiance reaching the surface of the PV can be determined by the incidence angle and the size of the PV.

Prediction Models

In this work, widely used machine learning models will be used for predictions, including k-nearest neighbour (k-NN), support vector machines (SVM), artificial neural networks (ANN). Different tests will be conducted for fine tuning of each algorithm.

The accuracy of the models is dependent upon different factors, which are as the following:

- The accurate measurement of weather forecast comparing to the actual weather data.
- The missing data is either due to transmission problems or the failure of nodes at any point in time.

The following will explain each prediction in the proposed model:

The Dust Accumulation Prediction: will estimate the dust accumulation on the PV surface over time based on the weather forecast data such as horizontal visibility, air quality, wind speed, wind directions, and rainfall considering the installation date. This prediction will have direct influence on the solar energy harvesting.

The Solar Energy Harvesting Prediction: This prediction will be based on the historical weather data, weather forecast data, PV data, the sun position and tilt angle, and the energy from the sensor node with respect of dust accumulation prediction.

Table 1: list of the data Parameters and Description from (K.A. CARE).

Parameters	Description
Air Temperature	The degree of hotness or coldness of the environment (measured by C°)
Wind Direction at 3m	Average wind direction at 3 meters height (measured by degree from North)
Wind Direction at 3m (std dev)	Standard deviation of the average wind direction data at 3 meters height
Wind speed at 3m	Average wind speed at 3 meters height (measured by m/s)
Wind speed at 3m (std dev)	Standard deviation of the average wind speed data at 3 meters height
Azimuth Angle	Defines the direction of the sun, Azimuth Angle is the angle between a line due south and the shadow cast by a vertical rod on Earth (measured by degree)
Diffuse Horizontal Irradiance (DHI)	Diffuse Horizontal Irradiance is the amount of radiation received per unit area by a surface that does not arrive on a direct path from the sun, but has been scattered by molecules and particles in the atmosphere (measured by W/m2)
Direct Normal Irradiance (DNI)	Direct Normal Irradiance is the amount of solar radiation received per unit area by a surface that is always held perpendicular to the rays that come in a straight line from the direction of the sun (measured by W/m2)
Global Horizontal Irradiance (GHI)	Global Horizontal Irradiance is the total amount of shortwave radiation received from above by a surface horizontal to the ground. This value includes both Direct Normal Irradiance and Diffuse Horizontal Irradiance (measured by W/m2)
Horizontal Visibility	The greatest distance toward the horizon that prominent objects can be identified visually with the naked eye (measured by km)
Peak Wind Direction at 3m	Greatest value of wind direction at 3 meters height (measured by degree from North)
Peak Wind Speed at 3m	Greatest value of wind speed at 3 meters height (measured by m/s)
Relative Humidity	Relative humidity is the ratio of the partial pressure of water vapor to the equilibrium vapor pressure of water at the same temperature (measured by %)
Barometric Pressure	Atmospheric pressure or barometric pressure, is the pressure exerted by the weight of air in the atmosphere of Earth (measured by mBar)
Zenith Angle	The solar zenith angle is the angle between the zenith and the center of the sun (measured by degree)

Table 2: Lists of The Data Required for Modelling.

DATA	LIST
Historical Weather Data	Air Temperature, Diffuse Horizontal Irradiance (DHI), Direct Normal Irradiance (DNI), Global Horizontal Irradiance (GHI), Azimuth Angle, Zenith Angle, Horizontal Visibility, Peak Wind Direction at 3m, Peak Wind Speed at 3m, Wind Direction at 3m, Wind Direction at 3m (std dev), Wind speed at 3m, Wind speed at 3m (std dev), Relative Humidity, Barometric Pressure, Time and Date.
Weather Forecast and Alerts	Wind Speed and Direction, Temperature, Pressure, Humidity, Air Quality, Visibility, Clouds, Dewpoint, Rain, Time and Date.
Photovoltaic Data	PV Size, Efficiency, Voltage at Peak Power, Current at Peak Power.
Sun Position and PV Tilt Angle	Zenith, Azimuth. Location, time of sunrise and sunset. PV Tilt Angle and Orientation.
Energy Data from Node	Battery level, Solar energy harvested.

Battery Gain Prediction: Based on the prediction of The Solar Energy Harvesting and the battery level measurement at night when there is no solar energy, taking into account the energy storage discharging cycle. The battery level data and the actual energy harvested data will indicate the energy consumption for the sensor tasks operation. Hence,

this information will be used for more machine learning to improve the predictions.

Battery Level Prediction: Based on the prediction of the battery gain and the energy consumption for the given tasks. The energy consumption will be determined by how many tasks

will be scheduled for that day. The model will use the data from the previous days to improve the prediction accuracy over time.

Tasks Scheduling: When scheduling tasks for IoT node, two factors need to be considered: the amount of energy will be consumed in that time period and the maximum utilization from the assigned energy. Different Tasks Schedules will be tested to

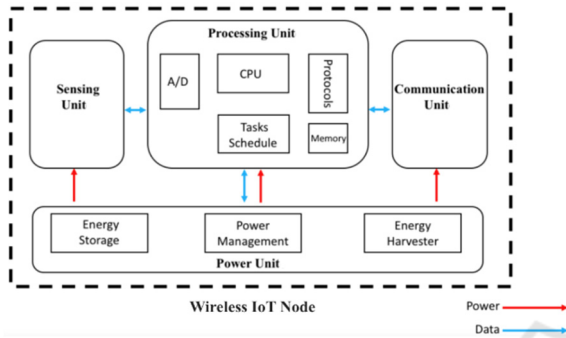

Figure 2: Block diagram for the proposed Wireless IoT Node Architecture.

4 CONCLUSIONS AND FUTURE WORK

Wireless IoT sensors are widely used nowadays. Sensors can be employed in remote locations and harsh environments. Their operation lifetime depends on their energy supply. Powering such devices via solar energy harvesting systems enables the continuous work. For optimal use of the available energy, the IoT device can schedule its operation according to the available energy. In order to achieve this, the prediction of the future energy which can be harvested is required. Therefore, understanding the effects of the environment on the solar energy harvesting needed.

This research will be defining the most relevant weather parameters and scenarios based on the literature. Identify the possible scenarios help in assessing the model in several operating conditions. The developed scenarios will be simulated to understand the effect of these scenarios on energy harvesting. For example, if it rains after a dusty day, what is the impact on solar energy harvesting. Furthermore, the effective input features for the prediction will be studied and identified and will be tested in the simulation phase. The widely used machine learning algorithms Support Vector Machines (SVM) is most known as state-of-the-arts forecasting models based on machine learning. These

models are data-driven, and they are suitable for short-term as intra-hours and long-term as next-day forecasts. These forecasting models will be tested in terms of prediction accuracy and energy efficiency.

REFERENCES

- Adinoyi, M. J., & Said, S. A. (2013). Effect of dust accumulation on the power outputs of solar photovoltaic modules. *Renewable energy*, 60, 633-636.
- Belaid, S., & Mellit, A. (2016). Prediction of daily and mean monthly global solar radiation using support vector machine in an arid climate. *Energy Conversion and Management*, 118, 105-118.
- Bergonzini, C., Brunelli, D., & Benini, L. (2009, June). Algorithms for harvested energy prediction in batteryless wireless sensor networks. In 2009 3rd International workshop on advances in sensors and interfaces (pp. 144-149). IEEE.
- Choudhary, P., Bhargava, L., Singh, V., Choudhary, M., & kumar Suhag, A. (2020). A survey—Energy harvesting sources and techniques for internet of things devices. *Materials Today: Proceedings*, 30, 52-56.
- Coello, M., & Boyle, L. (2019). Simple model for predicting time series soiling of photovoltaic panels. *IEEE J. Photovolt*, 9(5), 1382-1387.
- Dhaundiyal, A., & Atsu, D. (2020). The effect of wind on the temperature distribution of photovoltaic modules. *Solar Energy*, 201, 259-267.
- Du, D., Darkwa, J., & Kokogiannakis, G. (2013). Thermal management systems for photovoltaics (PV) installations: a critical review. *Solar Energy*, 97, 238-254.
- García, M., Marroyo, L., Lorenzo, E., & Pérez, M. (2011). Soiling and other optical losses in solar-tracking PV plants in navarra. *Progress in Photovoltaics: Research and Applications*, 19(2), 211-217.
- Garg, N., & Garg, R. (2017, December). Energy harvesting in IoT devices: A survey. In 2017 International Conference on Intelligent Sustainable Systems (ICISS) (pp. 127-131). IEEE.
- Gyrard, A., Zimmermann, A., & Sheth, A. (2018). Building IoT-based applications for smart cities: How can ontology catalogs help?. *IEEE Internet Things J*, 5(5), 3978-3990.
- Hachicha, A. A., Al-Sawafta, I., & Said, Z. (2019). Impact of dust on the performance of solar photovoltaic (PV) systems under United Arab Emirates weather conditions. *Renewable Energy*, 141, 287-297.
- Hegazy, A. A. (2001). Effect of dust accumulation on solar transmittance through glass covers of plate-type collectors. *Renewable energy*, 22(4), 525-540.
- Ilse, K. K., Figgis, B. W., Naumann, V., Hagendorf, C., & Bagdahn, J. (2018). Fundamentals of soiling processes on photovoltaic modules. *Renewable and Sustainable Energy Reviews*, 98, 239-254.
- Kansal, A., Hsu, J., Zahedi, S., & Srivastava, M. B. (2007). Power management in energy harvesting sensor

- networks. *ACM Trans. Embedded Comput Syst (TECS)*, 6(4), 32-es.
- Katkar, A. A., Shinde, N. N., & Patil, P. S. (2011). Performance & evaluation of industrial solar cell wrt temperature and humidity. *International Journal of research In Mechanical engineering and technology*, 1(1), 69-73.
- Khan, J. A., Qureshi, H. K., & Iqbal, A. (2015). Energy management in wireless sensor networks: A survey. *Computers & Electrical Engineering*, 41, 159-176.
- Kosmopoulos, P. G., Kazadzis, S., Taylor, M., Athanasopoulou, E., Speyer, O., Raptis, P. I., & Kontoes, C. (2017). Dust impact on surface solar irradiance assessed with model simulations, satellite observations and ground-based measurements. *Atmospheric Measurement Techniques*, 10(7), 2435.
- Loh, F., Geißler, S., Schaible, F., & Hoßfeld, T. (2021, January). Talk to Me: Investigating the Traffic Characteristics of Amazon Echo Dot and Google Home. In *2020 IEEE Eighth International Conference on Communications and Electronics (ICCE)* (pp. 521-526). IEEE
- Mazón, R., Káiser, A. S., Zamora, B., García, J. R., & Vera, F. (2011, November). Analytical model and experimental validation of the heat transfer and the induced flow in a PV cooling duct in environmental conditions. In *World Renewable Energy Congress-Sweden*; 8-13 May; 2011; (No. 057, pp. 2907-2915).
- Micheli, L., & Muller, M. (2017). An investigation of the key parameters for predicting PV soiling losses. *Progress in photovoltaics: research and applications*, 25(4), 291-307.
- Micheli, L., Deceglie, M. G., & Muller, M. (2019). Predicting photovoltaic soiling losses using environmental parameters: An update. *Progress in Photovoltaics: Research and Applications*, 27(3), 210-219.
- Newell, D., & Duffy, M. (2019). Review of power conversion and energy management for low-power, low-voltage energy harvesting powered wireless sensors. *IEEE Trans. Power Electron*, 34(10), 9794.
- Piñuela, M., Mitcheson, P. D., & Lucyszyn, S. (2013). Ambient RF energy harvesting in urban and semi-urban environments. *IEEE Trans. Microw. Theory techn*, 61(7), 2715-2726.
- Piorno, J. R., Bergonzini, C., Atienza, D., & Rosing, T. S. (2009, May). Prediction and management in energy harvested wireless sensor nodes. In *2009 1st International Conference on Wireless Communication, Vehicular Technology, Information Theory and Aerosp. Electron Syst Technol* (pp. 6-10). IEEE.
- Rahman, M. M., Hasanuzzaman, M., & Abd Rahim, N. (2017). Effects of operational conditions on the energy efficiency of photovoltaic modules operating in Malaysia. *Journal of cleaner production*, 143, 912-924.
- Rahman, M. M., Hasanuzzaman, M., & Rahim, N. A. (2015). Effects of various parameters on PV-module power and efficiency. *Energy Conversion and Management*, 103, 348-358.
- Said, S. A., & Walwil, H. M. (2014). Fundamental studies on dust fouling effects on PV module performance. *Solar Energy*, 107, 328-337.
- Said, S. A., Al-Aqeeli, N., & Walwil, H. M. (2015). The potential of using textured and anti-reflective coated glasses in minimizing dust fouling. *Solar Energy*, 113, 295-302.
- Sarver, T., Al-Qaraghuli, A., & Kazmerski, L. L. (2013). A comprehensive review of the impact of dust on the use of solar energy: History, investigations, results, literature, and mitigation approaches. *Renewable and sustainable energy Reviews*, 22, 698-733.
- Sayigh, A., Al-Jandal, S., & Ahmed, H. (1985, September). Dust effect on solar flat surfaces devices in Kuwait. In *Proceedings of the workshop on the physics of non-conventional energy sources and materials science for energy* (pp. 353-367). ICTP Triest, Italy.
- Sharma, N., Gummesson, J., Irwin, D., & Shenoy, P. (2010, June). Cloudy computing: Leveraging weather forecasts in energy harvesting sensor systems. In *2010 7th Annual IEEE Communications Society Conference on Sensor, Mesh and Ad Hoc Communications and Networks (SECON)* (pp. 1-9). IEEE.
- Sparks, P. (2017). The route to a trillion devices. White Paper, ARM.
- Tong, B., Wang, G., Zhang, W., & Wang, C. (2011). Node reclamation and replacement for long-lived sensor networks. *IEEE Trans. Parallel Distrib. Syst*, 22(9), 1550-1563.
- Toth, S., Hannigan, M., Vance, M., & Deceglie, M. (2020). Predicting photovoltaic soiling from air quality measurements. *IEEE J. Photovolt*, 10(4), 1142-1147.
- Weather API. (n.d.). Retrieved 11 January 2022, from Openweathermap.org website: <https://openweathermap.org/api>
- Yadav, A. K., & Chandel, S. S. (2014). Solar radiation prediction using Artificial Neural Network techniques: A review. *Renewable and sustainable energy reviews*, 33, 772-781.
- Yang, H. T., Huang, C. M., Huang, Y. C., & Pai, Y. S. (2014). A weather-based hybrid method for 1-day ahead hourly forecasting of PV power output. *IEEE trans. Sustain.Energy*, 5(3), 917-92.