

# Wave Equation Model of Soft Tissue for a Virtual Reality Laparoscopy Training System

## *A Validation Study*

Sneha Patel and Jackrit Suthakorn

*Center for Biomedical and Robotics Technology (BART LAB), Department of Biomedical Engineering, Mahidol University, Salaya, Nakhon Pathom, Thailand*

**Keywords:** Soft Tissue Modeling, Surgical Training, Wave Equation, Finite Element Analysis (FEA).

**Abstract:** Laparoscopic procedures have various benefits for the patients but come with environmental limitations for the surgeons. Therefore to prevent serious complications, surgeons require intensive and repetitive training to acquire essential techniques, skills or tasks. There are various training systems used in surgical programs; a recent technology that shows promise is virtual reality (VR) training. An important aspect of these training systems is the realism of the soft tissue model and the user interface, which allow effective transference of skills from the training system to the operating room. This paper discusses a novel method to model soft tissue in virtual reality training systems and the validation of this model. Wave equation, a mathematical model, is used to model the soft tissue and laparoscopic tools' interaction. This model is validated using finite element analysis, which is used to compare the mechanical properties of the resulting material and human skin. The model discussed in this paper will be applied to a novel surgical training system, which trains the user in laparoscopic suturing techniques.

## 1 INTRODUCTION

Laparoscopic surgeries, today, are the procedure of choice due to the benefits of this technique for the patients. These benefits include: shorter recovery period, reduced blood loss, and less scarring; all of which are a result of the smaller incisions utilized in the procedure (Basdogan et al., 2001). Despite the benefits for patients, this procedure comes with a number of limitations for the surgeon, some of which include (Bashankaev et al., 2011, Roberts et al., 2006, Derossis et al., 1998):

- 2-dimensional view of operating area
- Limited hand-eye coordination
- Increased tremor due to long, inflexible tools
- Restricted movement

### 1.1 Need for Laparoscopic Surgery Training

Due to the limitations of the operating environment, surgeons require intensive training to prevent serious complications, e.g. bleeding, infection, visceral injury or death. These complications are most

commonly observed in procedures performed by inexperienced surgeons (See et al., 1993, Wherry et al., 1998).

### 1.2 Present Surgical Training Systems



Figure 1: Physical interface, of BART LAB's VR training system, which attaches laparoscopic tools to two Phantom Omnis; haptic devices used for user interaction.

The conventional surgical training device is live or cadaveric human, but due to the cost and ethical issues associated with these systems, surgical programs are moving towards inanimate training systems. These systems can utilize either synthetic

models or virtual reality (VR) models, which allow repetitive training and quantitative assessment (Munz et al., 2004). VR training systems show promise in this field and are being extensively researched because it allows user-specific, repetitive, and intensive training with continuous, objective user assessment metric (Roberts et al., 2006, Munz et al., 2004). This is one of the many reasons for research into the development of a VR training system at our lab. The physical interface is displayed in figure 1 (Itsarachaiyot, 2012).

## 2 LITERATURE REVIEW

Presently, various VR training systems are used in medical schools to provide students or young surgeons with the required laparoscopic skills. These systems also utilize various modeling techniques to mimic the mechanical and material properties of soft tissue, in real time.

### 2.1 VR Training Systems

There are various VR training systems that are either commercially available or within the research process. These systems range in price from US\$5,000 to US\$200,000 (Sutherland et al., 2006). They also vary in the skills that they teach, since some focus on basic skills while others provide training in entire laparoscopic procedures (Ali et al., 2002). Some commercial VR training systems are: SIMENDO simulator, LAP Mentor, and LapSim Virtual Reality Simulator.

At our research lab, a previous researcher has developed a VR training system, with a focus on the forces applied and experienced, during a laparoscopic procedure (Itsarachaiyot, 2012). The forces are based on studies on porcine tissue (Itsarachaiyot et al., 2011). However, the realism of the virtual environment can still be improved; this environment is shown in figure 2.

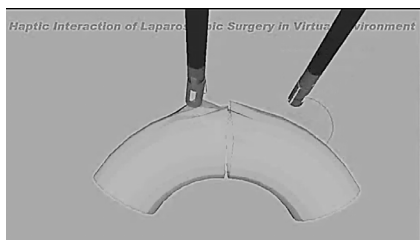

Figure 2: This figure shows the virtual environment of the training device, designed at our lab (Itsarachaiyot, 2012).

### 2.2 Representation of Soft Tissue in Present VR Training Systems

There are three, most commonly used, modeling techniques that are utilized to represent soft tissue in VR training systems: mass-spring model, finite element model, and mesh-free model.

Mass-spring model is the simplest form of modeling, which makes it an ideal model for real time manipulations. This method is based on the Kelvin-Voigt model which utilizes spring and dashpots to represent the viscoelastic properties of the soft tissue (Basdogan et al., 2004). This is the most commonly used technique to model biological materials in VR (Brown et al., 2002). A simple mass-spring model is utilized in our current training system (Itsarachaiyot, 2012).

On the other hand, the finite element model is a very accurate model of the interactions between a soft tissue and the laparoscopic tools. This accuracy comes at the price of computation which makes this a very slow model and therefore undesirable for a real time VR surgical training system (Brown et al., 2002). This model is a mesh, which is the initial condition of the surface, where vector fields are utilized to calculate deformation as a result of manipulations and interactions. (Brown et al., 2002, Basdogan et al., 2004).

Mesh-free model is designed to meet the needs of a surgical training system. The utility of this model comes from its ability to reconnect the tissue after being cut. This uses the principles of finite element modeling but is simplified to reduce the computation time. The material is manipulated using the displacement of clusters of nodes around the area of change (Basdogan et al., 2004).

### 2.3 Problems with Present Soft Tissue Models

VR training systems complement surgical training by preparing surgeons before they perform the procedure on a patient; however present systems have a few disadvantages. A major problem with present inorganic training systems is their lack of realistic simulations of internal organs and laparoscopic tools' interaction (Munz et al., 2004).

Present soft tissue models are either over simplified, e.g. mass-spring model and mesh-free models, or are computationally expensive, e.g. finite element model. Therefore, there is a need for the development of a model that can mimic the mechanical, material, and visual properties of the soft tissue for real time manipulations. This paper

discusses the use of wave equation to model the behavior of soft tissue in a VR training system to produce more effective transference from the training system to the operating room.

### 3 APPROACH

The flow chart in figure 3 outlines the method employed in this study; from developing the model to validating it. Each of the steps is covered in further detail in the following subsections. The computer that is used to study the wave equation and heterogeneous material model, has the following specifications: Intel Core 2 Duo 2.66 GHz processor, NVIDIA GeForce 9400 GT graphics card, 4 GB RAM, and 160 GB hard disk.

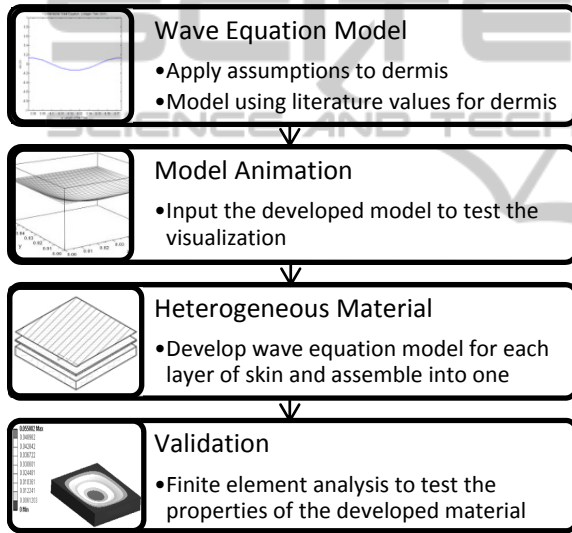

Figure 3: Overview of the approach of this study.

#### 3.1 Wave Equation as a Modeling Tool in Engineering

Wave equations are partial differential equations that are used to study vibrations in elastic and flexible, threads and membranes. In this study, two-dimensional wave equation is used to model soft tissue as it defines vibrations in thin membranes.

$$\frac{\delta^2 u}{\delta t^2} = c^2 \left( \frac{\delta^2 u}{\delta x^2} + \frac{\delta^2 u}{\delta y^2} \right); \quad c^2 = \frac{T}{\rho} \quad (1)$$

Equation (1) shows the two dimensional wave equation, where  $u(x,y,t)$  is the displacement function,  $T$  is the initial force on the membrane, and  $\rho$  is the density of the membrane. This equation is developed using Newton's 2<sup>nd</sup> Law.

$$u_{mn}(x, y, t) = (B_{mn} \cos \lambda_{mn} t + B_{mn}^* \sin \lambda_{mn} t) \times \sin \frac{m\pi x}{a} \sin \frac{n\pi y}{b}; \quad (2)$$

$$(m = 1, 2, 3 \dots), (n = 1, 2, 3 \dots)$$

$$= \frac{4}{ab} \int_0^b \int_0^a f(x, y) \sin \frac{m\pi x}{a} \sin \frac{n\pi y}{b} dx dy \quad (3)$$

$$\text{where } \lambda_{mn} = c\pi \sqrt{\frac{m^2}{a^2} + \frac{n^2}{b^2}} \text{ \& } c^2 = \frac{T}{\rho} \quad (4)$$

Kreyszig et al. determined the solution for the two dimensional equations using boundary and initial conditions; equations 2-4 (Kreyszig et al., 2011). This solution is developed using the idea of a drum membrane and the vibrations it experiences upon contact with the drumstick (Kreyszig et al., 2011). In these solutions  $m$  and  $n$  are integers,  $B_{mn}$  is the Euler formula used to determine the shape of the membrane,  $B_{mn}^*$  is the relation associated with the initial velocity (which is 0 in this scenario),  $a$  and  $b$  are the boundary conditions of the membrane, and  $\lambda_{mn}$  are the eigenvalues of the membrane model.

Structural engineers use wave equations to observe the effects of vibrations on beams, rods, cables and plates. In these studies, the objects are considered homogeneous and isotropic, with continuous properties of mass and spring. This model is used by engineers to determine the strength of various components of a building (Beards, 1996). For example, to observe the effects of vibrations, from earthquakes, to a building's integrity (Sánchez-Sesma et al., 2002). A model that is also related to soft tissue is the use of 2D wave equation to model vibrations of a drum membrane (Kreyszig et al., 2011).

Based on the authors' research, there is presently no study that utilizes wave equation to model the behavior of soft tissue in a surgical setting. A biomedical application of wave equation is the modeling of blood flow using partial differential equations, which define the fluid's dynamics (Bessems et al., 2007).

#### 3.2 Mechanical & Material Properties of the Dermis

Table 1 covers essential properties of the dermis because of its role in the mechanical behavior of the skin. Other layers of the skin, studied by the authors are the epidermis and subcutaneous fat (Silver et al., 2002). These properties are essential for the development of a 2D wave equation solution for dermis.

Table 1: Essential Properties of Dermis to Develop the 2D Wave Equation.

Properties of Dermis	Values
Area of Dermis	$60mm \times 60mm = 3600mm^2$
Thickness of Dermis	1mm (Silver et al., 2002)
Volume of Dermis	$60mm \times 60mm \times 1mm = 3600mm^3$
Weight of Dermis	$1.8 \times 10^{-8} \frac{g}{mm^2}$ (MacLaughlin and Holick, 1985) $\therefore Weight = (1.8 \times 10^{-8} \frac{g}{mm^2}) \times 3600mm^2 = 6.48 \times 10^{-5}g$
Density of Dermis	$\rho = \frac{m}{v} = \frac{6.48 \times 10^{-5}g}{3600mm^3} = 1.8 \times 10^{-8} \frac{g}{mm^3} = 18 \frac{g}{m^3}$
Prestress (along the fibers)	0.024 MPa (Hendriks, 2001)
Prestress (across the fibers)	0.0093 MPa (Hendriks, 2001)
Prestress <sup>a</sup>	$F = \sqrt{0.024^2 + 0.0093^2} = 2.57 \times 10^{-2}MPa$
Tension	$T = (2.57 \times 10^{-2})(60 \times 10^{-3}) = 1.54 \times 10^{-3} \frac{N}{m}$

a. Prestress identifies the natural force that affects skin, as a result of the connective tissues and bones, and their interaction with the skin.

### 3.3 Developing a Mathematical Model for a Layer of the Skin (Dermis)

#### 3.3.1 Applying the Assumptions of 2D Wave Equation to the Dermis

1. Mass of the dermis per unit area is constant.
2. The dermis is flexible therefore experiences bending without resistance.
3. The dermis is stretched and fixed throughout its boundary; as it is held in place by bones and connective tissues. This stretching results in a uniform tension per unit length T, which is constant during motion.
4. The deformation of the membrane is small compared to the size of the dermis, which is plausible since the area of deformation is smaller than the dermis that covers the entire body.
5. The membrane is thin, this is the reason why only a layer of skin, the dermis, is modeled using this equation. Multiple two dimensional wave equations are used to model all of the

layers of the skin to show how they would interact to create a specific manipulation.

#### 3.3.2 Wave Equation Solution Modeling the Mechanics of Human Dermis

Based on the 2D wave equation solution shown in subsection 3.1, the material properties of the dermis and the assumptions of the model, the equation below (equation (6)) is developed to model the dermis. On the other hand, equation 5 is the Euler formula.

$$B_{1,1} = \frac{4}{60 \times 60} \int_0^{0.06} \int_0^{0.06} (5x(1-x)) \times \sin \frac{\pi x}{0.06} \sin \frac{\pi y}{0.06} dx dy \tag{5}$$

$$u_{mn}(x, y, t) = ((6.11 \times 10^{-6}) \cos(0.686t)) \times \sin \frac{\pi x}{0.06} \sin \frac{\pi y}{0.06} \tag{6}$$

#### 3.4 Animation of the Dermis Model

The author created an animated model of the dermis in a symbolic math toolbox. This animation is used to test the 2D wave equation and the visualization that the model produces. The simple interaction of a laparoscopic tool pushing down on the soft tissue, causing deformation of the soft tissue and then the return of the tissue to its original form, is demonstrated in this animation.

#### 3.5 Creating a Heterogeneous Model to Replicate the Soft Tissue

In this paper, the author describes the development of a two-dimensional wave equation for a single layer of the soft tissue. However, the researcher has developed this model for two other layers of the skin (as can be seen in the appendix); therefore allowing the representation of the mechanical and material properties of the different layers of the skin. The models for each of the layers are put together to create a heterogeneous material like biological skin. This model will represent the soft tissue in the VR training system.

To create a heterogeneous material, the author created a  $60mm \times 60mm \times thickness\_of\_tissue$  model for each of the three layers of the skin, which are epidermis, dermis, and subcutaneous fat. An assembly of all these sections is created in a finite element analysis software; in which important material and mechanical properties of the soft tissue are applied. The material properties that are used to

define each of the layers are: density, damping factor, Young's Modulus, Poisson's ratio, and tensile yield strength. These values are based on the data from the following studies: (Zahouani et al., 2009, Silver et al., 2002, Geerligts et al., 2011, Geerligts et al., 2008, Gibney et al., 2010).

### 3.6 Validation of the Skin Model

As this is a novel soft tissue model, a validation study is performed to corroborate the mathematical model with the behavior of the biological tissue. This study looks at the mechanical properties of the designed wave equation models with respect to the skin. Previous studies have used qualitative methods, e.g. surveys or questionnaires to assess their tissue models (Fried et al., 2004, Gavazzi et al., 2011). On the other hand, this study aims to use a quantitative method for a more objective analysis. Because of this, the authors are using FEA models to get data from an accurate model and compare this to the wave equation model developed in the subsections above.

For this study, a heterogeneous material is recreated in a FEA program to ensure correct material properties' assignment to each of the layers that are modeled. The material properties of the soft tissue are introduced for each layer, to accurately mimic the properties of the soft tissue.

Using the FEA model, a static study is performed on the resulting heterogeneous material. In this system, the boundaries of all the layers are treated as fixed supports to complement the assumption applied to the solution of the wave equation. A total force of 5N is applied at increments of 0.05N over a time period of 100 seconds. Like the deformation in the wave equation model, this model focuses on the simple action of pushing down on the soft tissue with a laparoscopic tool. To get solutions for a comparison, the data from the developed wave equation models are manipulated to find the maximum deformation at each layer at every time increment.

Using this data, a statistical analysis is performed to compare the two models. First, a normal distribution study is performed to compare the behavior of the two models. Subsequently, a t-test is performed to compare the two models at each of the layers of the skin. The researchers use the maximum deformation values to compare the two models, because the aim of the wave equation model is a novel method to improve the visualization of the soft tissue model in a VR training system.

## 4 RESULTS

### 4.1 Animation of the Dermis

The animation that is developed using the wave equation shows the behavior of the modeled soft tissue when pushed on and its return back to the original shape. Figure 4 is a set of screenshots from the developed animation and shows the transitions of the soft tissue during the described tool manipulation.

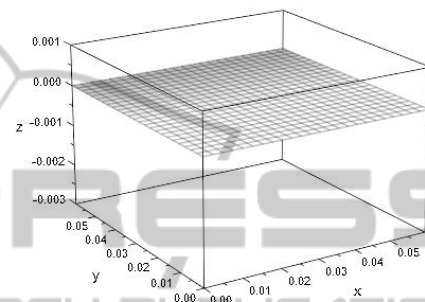

(a) At 0 seconds

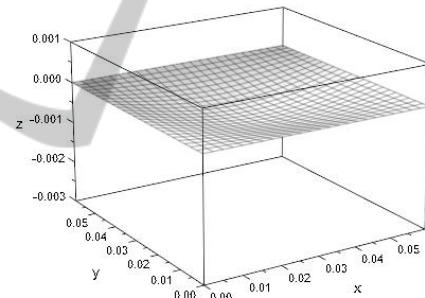

(b) At 1.5 seconds

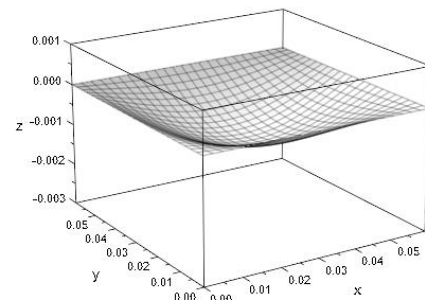

(c) At 4.8 seconds

Figure 4: The animation, which is created to check the visualization of the 2D wave equation for the dermis. Figures (a-c) show the steps the model takes to deform downward whereas figure 2 (d) shows the soft tissue as it returns back to its original shape. The units of the x,y,z are meters therefore the values are very small as the deformation would be very minute at this unit.

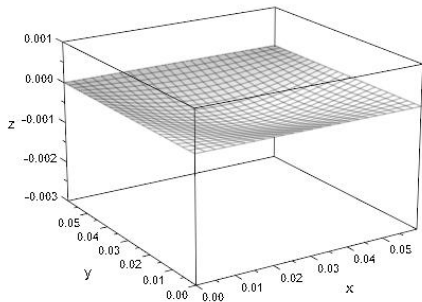

(d) At 8.5 seconds

Figure 4: The animation, which is created to check the visualization of the 2D wave equation for the dermis. Figures (a-c) show the steps the model takes to deform downward whereas figure 2 (d) shows the soft tissue as it returns back to its original shape. The units of the x,y,z are meters therefore the values are very small as the deformation would be very minute at this unit.(cont.)

#### 4.2 Heterogeneous Material: Skin

Figure 5 looks at the heterogeneous material that is developed for the finite element analysis. This image shows the exploded view of the developed material to demonstrate the three skin layers that are makeup the soft tissue model. As mentioned earlier, the layers that this model focuses on are the epidermis, dermis, and subcutaneous fat. As can be seen from figure 5, the layers can be distinguished by their thicknesses; this information is based on literature values from: (Hendriks, 2001, Silver et al., 2002, Gibney et al., 2010).

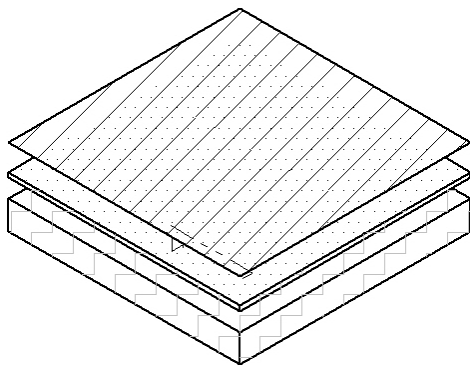

Figure 5: This figure shows the isometric and exploded view of the soft tissue. Here, the hatched layer is the epidermis, the dotted layer is the dermis and the layer with the zigzag pattern is the subcutaneous fat.

#### 4.3 Mechanical Properties of the Heterogeneous Model

This section, demonstrates the results that are

statistically analyzed to compare the two models. Figure 6 aims to demonstrate the maximum deformations from the two models, during the soft tissue manipulations. On the other hand, figure 7, shows results from the finite element analysis. These results are like those seen in the wave equation animation.

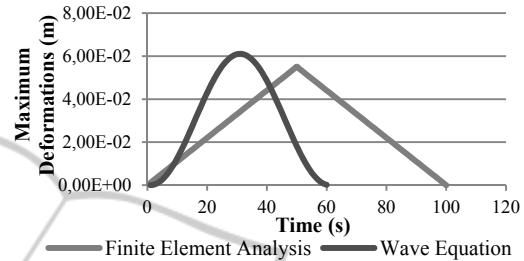

Figure 6: This graph shows the maximum deformations observed in the wave equation and finite element models of the dermis.

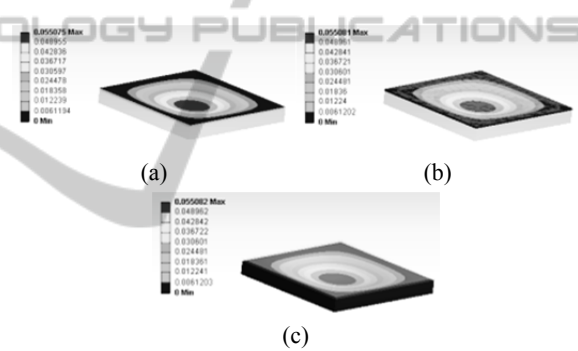
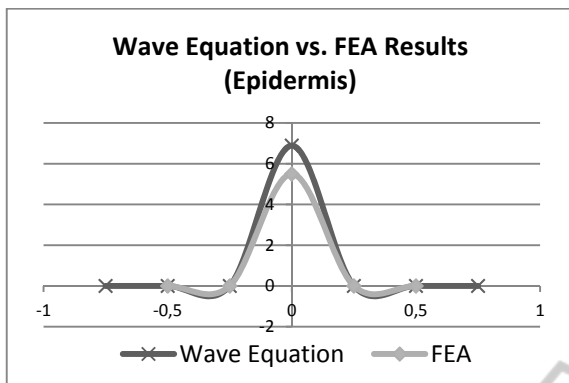

Figure 7: Here, is a representation of the deformation of three layers in the FEA model [(a) epidermis, (b) dermis and (c) subcutaneous fat] of the heterogeneous material.

#### 4.4 Statistical Analysis

##### 4.4.1 Normal Distribution

The normal distribution studies, graphed in figure 8 (a-c), show high variability between the wave equation models and the heterogeneous FEA material. The values that are plotted in figure 8 are based on the maximum deformations at different time periods in the FEA software. On the other hand, for the wave equation model, the models for the different layers are calculated and maximum deformation values at each time interval are found, from the raw data. The calculations in this statistical analysis are performed using various functions in Microsoft Excel.



(a)

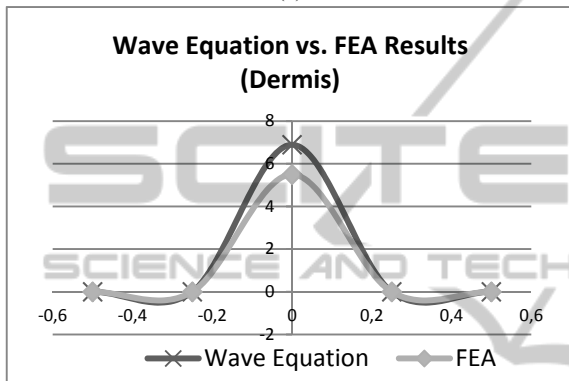

(b)

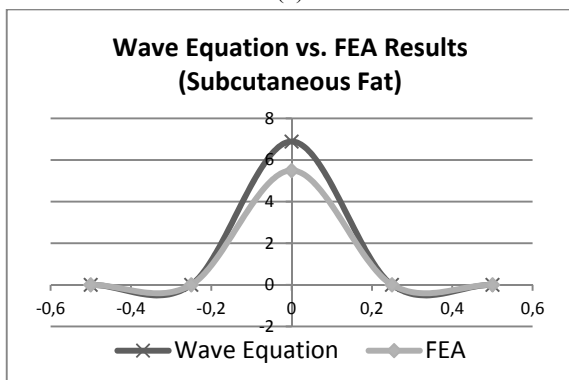

(c)

Figure 8: Figures (a-c) are graphs that demonstrate normal distribution tests for the different layers (epidermis, dermis, subcutaneous fat; respectively) to show the relationships between the two models discussed in the methods section. Here the line with (x) marker represents the results from the wave equation whereas the line with (♦) marker represents the results from the mechanical study of the finite element model.

#### 4.4.2 T-Test

The t-test results that are displayed in table 2 are based on the results found using the Data Analysis Toolpak in Microsoft Excel. The t-test is designed

for two samples assuming equal variances where  $\alpha = 0.05$ ; alpha is the significance level that we are employing in the analysis. The null hypothesis in this analysis is that the means are equal, which we would expect since the models are of the same tissue. On the other hand, the alternative hypothesis is that the means are not equal. All the values displayed in the table are rounded to the nearest thousandth.

Table 2: This table shows the t-values found for the comparison between the wave equation model and finite element model for each layer of the skin.

T-test Results	
<b>Epidermis</b>	
<i>P (Two Tail)</i>	0.364
<i>t Stat</i>	-0.912
<i>t Critical Value</i>	1.975
<b>Dermis</b>	
<i>P (Two Tail)</i>	0.395
<i>t Stat</i>	0.911
<i>t Critical Value</i>	1.975
<b>Fat</b>	
<i>P (Two Tail)</i>	0.363
<i>t Stat</i>	0.853
<i>t Critical Value</i>	1.975

## 5 DISCUSSION

### 5.1 Data Analysis

Despite the fact that the plot of the maximum deformations for the two models are different (Figure 6), due to the rate at which the two models move, the two datasets show similarities as expected from models of the same material. Along with that the wave equation has a smoother transition when there is a change in the direction of the force applied.

The results from the statistical analysis can provide a comparison between the wave equation and heterogeneous material models.

When we analyze the normal distribution of the data, from the two models for each of the layers of the soft tissue, it can be concluded that the two data sets have high variability. High variability in the normal distribution study suggests high correlation between the two models, which would be expected since they model the same biological material.

The t-test is performed with the null hypothesis that the two data sets have equal variances. There are two ways the results from table 2 can be used to determine whether the null hypothesis is rejected or not. The first is if  $p - value > 0.05$  whereas the

second is if  $t_{stat} < t_{critical}$ . These two relationships are seen in the three t-tests that are performed for each of the layers of the skin. These results therefore suggest that the null hypothesis can not be rejected and the means are the same. These results display similarities and correlations as would be expected from models of the same soft tissue.

As discussed earlier in the literature review, FEA is computationally expensive for real time simulation and therefore, despite its accuracy, it is not the choice of model for surgical simulation. During this study the user is able to observe the difference between the wave equation model and the FEA model, and their computational cost. The wave equation results are acquired in 6 seconds whereas solving the FEA model takes approximately 4 minutes.

The computational cost and the statistical analysis support the use of wave equation as a model of soft tissue in a surgical simulation.

## 5.2 Protocol Analysis

The heterogeneous material in this paper is an oversimplified version of the actual soft tissue. This is because it does not take into consideration the connective tissues, blood vessels, hair follicle and other components that makeup the skin structure. It is important to look into the effects of these components on the mechanics and therefore the model of skin. Also, the thickness of the layers in the novel model is consistent throughout the layer, which wouldn't be the case for the biological material. This inaccuracy can be resolved by adding materials of various sizes to the assembly of the heterogeneous material, in future models.

Although, this study models skin using wave equation, the ultimate goal of this study is to transform this mathematical model, so that it can easily be modified or altered to complement the mechanical behavior of different soft tissues based on the needs of the trainee, surgeon, or procedure.

## 5.3 Future Application of Model

This model of skin will be implemented into a VR training system for the development of laparoscopic surgery skills. Figure 9 shows the overall system that will be developed using the soft tissue model discussed in this paper.

Located in a developing nation, our lab appreciates the need for skilled doctors in laparoscopic procedures. This knowledge is less attainable in the rural parts of the country and this

lack of information makes it extremely challenging for doctors in these parts of the country to provide the same level of healthcare as seen in the capital city.

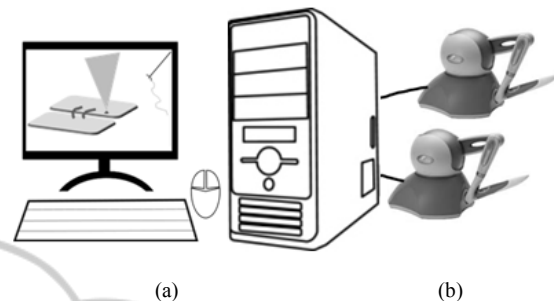

Figure 9: This diagram shows the conceptual design of the overall system that the authors aim to design. As can be seen, there are two components: a) the graphical user interface that consists of the soft tissue model from this paper, laparoscopic tools, and directions for proper technique and b) the haptic interface that will allow realistic interaction with the user interface.

This system aims to produce a more realistic interaction between the user and the user interface therefore allowing a more accurate transference of skills from the training system to the operating room. This VR training system will teach the user proper laparoscopic suturing techniques; a difficult task. It will also provide the user with an objective assessment of their performance on the device therefore monitoring the user's skills and techniques over the training period. A successful system will provide people around the country with quality healthcare.

## 6 CONCLUSIONS

Laparoscopic surgeries are trending due to the benefits for the patient, despite the constraints the surgeons experience in a minimally invasive environment. This paper discusses a novel mathematical model to improve the realism and visualization of the soft tissue in a VR training system. The proposed method utilizes wave equation to model soft tissue and laparoscopic tools' interaction. The soft tissue model shows promise, based on the comparison with the FEA model, which is one of the most accurate methods of modeling in VR. In future studies, this model will be implemented into a novel training system and the effectiveness of the system as a training device will be assessed based on the ability of the device to



allow repetitive training with continuous performance feedback.

## ACKNOWLEDGMENT

The authors would like to thank Thailand's National Research Universities Grant through Mahidol University for their financial support. The first author would like to take this opportunity to thank Aditya Birla Group's Pratibha Scholarship, and the Department of Biomedical Engineering's Biomedical Engineering Scholarship (BMES) for providing financial aid for her graduate education. The first author would also like to thank her colleagues at BART LAB for their continuous support and assistance, throughout her time at the laboratory.

## REFERENCES

- Ali, M. R., Mowery, Y., Kaplan, B. & Demaria, E. J. 2002. Training The Novice In Laparoscopy. More Challenge Is Better. *Surg Endosc*, 16, 1732-6.
- Basdogan, C., De, S., Kim, J., Muniyandi, M., Kim, H. & Srinivasan, M. A. 2004. Haptics In Minimally Invasive Surgical Simulation And Training. *Ieee Comput Graph Appl*, 24, 56-64.
- Basdogan, C., Ho, C.-H. & Srinivasan, M. A. 2001. Virtual Environments For Medical Training: Graphical And Haptic Simulation Of Laparoscopic Common Bile Duct Exploration. *Mechatronics, Ieee/Asme Transactions On* 6, 269-285.
- Bashankaev, B., Baido, S. & Wexner, S. D. 2011. Review Of Available Methods Of Simulation Training To Facilitate Surgical Education. *Surg Endosc*, 25, 28-35.
- Beards, C. 1996. The Vibration Of Continuous Structures. *Structural Vibration: Analysis And Damping*. Burlington, Ma: Butterworth-Heinemann.
- Bessems, D., Rutten, M. & Van De Vosse, F. 2007. A Wave Propagation Model Of Blood Flow In Large Vessels Using An Approximate Velocity Profile Function. *Journal Of Fluid Mechanics*, 580, 145-168.
- Brown, J., Sorkin, S., Latombe, J. C., Montgomery, K. & Stephanides, M. 2002. Algorithmic Tools For Real-Time Microsurgery Simulation. *Med Image Anal*, 6, 289-300.
- Derossis, A. M., Fried, G. M., Abrahamowicz, M., Sigman, H. H., Barkun, J. S. & Meakins, J. L. 1998. Development Of A Model For Training And Evaluation Of Laparoscopic Skills. *Am J Surg*, 175, 482-7.
- Fried, G. M., Feldman, L. S., Vassiliou, M. C., Fraser, S. A., Stanbridge, D., Ghituiescu, G. & Andrew, C. G. 2004. Proving The Value Of Simulation In Laparoscopic Surgery. *Ann Surg*, 240, 518-25; Discussion 525-8.
- Gavazzi, A., Bahsoun, A. N., Van Haute, W., Ahmed, K., Elhage, O., Jaye, P., Khan, M. S. & Dasgupta, P. 2011. Face, Content And Construct Validity Of A Virtual Reality Simulator For Robotic Surgery (Sep Robot). *Ann R Coll Surg Engl*, 93, 152-6.
- Geerligts, M., Peters, G. W., Ackermans, P. A., Oomens, C. W. & Baaijens, F. P. 2008. Linear Viscoelastic Behavior Of Subcutaneous Adipose Tissue. *Biorheology*, 45, 677-88.
- Geerligts, M., Van Breemen, L., Peters, G., Ackermans, P., Baaijens, F. & Oomens, C. 2011. In Vitro Indentation To Determine The Mechanical Properties Of Epidermis. *J Biomech*, 44, 1176-81.
- Gibney, M. A., Arce, C. H., Byron, K. J. & Hirsch, L. J. 2010. Skin And Subcutaneous Adipose Layer Thickness In Adults With Diabetes At Sites Used For Insulin Injections: Implications For Needle Length Recommendations. *Curr Med Res Opin*, 26, 1519-30.
- Hendriks, F. M. 2001. Mechanical Behaviour Of Human Skin In Vivo: A Literature Review. *Koninklijke Philips Electronics N.V., Nat. Lab. Unclassified Report* 1-46.
- Itsarachaiyot, Y. 2012. *Haptic Interaction Of Laparoscopic Surgery In Virtual Environment*. Master Of Engineering, Mahidol University.
- Itsarachaiyot, Y., Pochanakorn, R., Nillahoot, N. & Suthakorn, J. Force Acquisition On Surgical Instruments For Virtual Reality Surgical Training System. 2011 International Conference On Computer Control And Automation (Iccca 2011), May 1-May 3 2011 Jeju Island, South Korea. *Ieee*, 173-176.
- Kreyszig, E., Kreyszig, H. & Norminton, E. J. 2011. Partial Differential Equations (Pdes). In: Corliss, S. (Ed.) *Advanced Engineering Mathematics*. 10 Ed. United States Of America: John Wiley & Sons Inc.
- Maclaughlin, J. & Holick, M. F. 1985. Aging Decreases The Capacity Of Human Skin To Produce Vitamin D3. *J Clin Invest*, 76, 1536-8.
- Munz, Y., Kumar, B. D., Moorthy, K., Bann, S. & Darzi, A. 2004. Laparoscopic Virtual Reality And Box Trainers: Is One Superior To The Other? *Surg Endosc*, 18, 485-94.
- Roberts, K. E., Bell, R. L. & Duffy, A. J. 2006. Evolution Of Surgical Skills Training. *World J Gastroenterol*, 12, 3219-24.
- Sánchez-Sesma, F. J., Palencia, V. J. & Luzón, F. 2002. Estimation Of Local Site Effects During Earthquakes: An Overview. *Iset Journal Of Earthquake Technology*, 39, 167-193.
- See, W. A., Cooper, C. S. & Fisher, R. J. 1993. Predictors Of Laparoscopic Complications After Formal Training In Laparoscopic Surgery. *Jama*, 270, 2689-2692.
- Silver, F. H., Seehra, G. P., Freeman, J. W. & Devore, D. 2002. Viscoelastic Properties Of Young And Old Human Dermis: A Proposed Molecular Mechanism For Elastic Energy Storage In Collagen And Elastin. *Journal Of Applied Polymer Science*, 86, 1978-1985.

Sutherland, L. M., Middleton, P. F., Anthony, A., Hamdorf, J., Cregan, P., Scott, D. & Maddern, G. J. 2006. Surgical Simulation: A Systematic Review. *Ann Surg*, 243, 291-300.

Weigand, D. A., Haygood, C. & Gaylor, J. R. 1974. Cell Layer And Density Of Negro And Caucasian Stratum Corneum. *J Invest Dermatol*, 62, 563-568.

Wherry, D. C., Rob, C. G., Marohn, M. R. & Rich, N. M. 1998. An External Audit Of Laparoscopic Cholecystectomy Performed In Medical Treatment Facilities Of The Department Of Defense. *Ann Surg*, 220, 626-634.

Zahouani, H., Pailler-Mattei, C., Sohm, B., Vargiolu, R., Cenizo, V. & Debret, R. 2009. Characterization Of The Mechanical Properties Of A Dermal Equivalent Compared With Human Skin In Vivo By Indentation And Static Friction Tests. *Skin Res Technol*, 15, 68-76.

## APPENDIX

### 2D Wave Equation Solution to Model Other Layers of the Skin

As discussed in this paper, the skin is considered a heterogeneous material, in this study; therefore this section of the appendix shows the models for the two other layers.

$$u_{mn}(x, y, t) = [(6.11 \times 10^{-6}) \cos(0.0032t)] \times \sin \frac{\pi x}{0.06} \sin \frac{\pi y}{0.06} \quad (7)$$

The equation above (equation 7) models the properties of the epidermis, using data from studies on the human skin (Hendriks, 2001, Weigand et al., 1974).

The second equation (equation 8), here, represents the 2D model of the subcutaneous fat. The equation is determined using the following studies: (Hendriks, 2001, MacLaughlin and Holick, 1985, Gibney et al., 2010).

$$u_{mn}(x, y, t) = (6.11 \times 10^{-6}) \times \cos(5.31 \times 10^{-4}t) \times \sin \frac{\pi x}{0.06} \sin \frac{\pi y}{0.06} \quad (8)$$