

# Exhaust Thermoelements Redundant Strategy to Improve Temperature Reading Reliability and Serviceability

T. Addabbo, O. Cordovani, A. Fort, M. Mugnaini and V. Vignoli

*Department of Information Engineering and Mathematics, University of Siena, 53100, Siena, Italy*

**Keywords:** System Reliability, Availability, Thermal Sensors, Gas Turbine, System Redundancy.

**Abstract:** Pollution linked to power generation is strictly connected to gas turbine control algorithms and efficiency performance. Parts life is affected by quality and type of combustion too. The control of the exhaust temperature is therefore a key parameter to indirectly monitor the effectiveness of the combustion in all the combustion chamber of an heavy duty gas turbine. Actually due to the high temperature and dynamics of the combustion chambers the performance measurement of the combustion is achieved through indirect pressure and temperature monitoring. Moreover, exhaust temperature monitoring may allow to avoid dangerous situations connected to flame loose in combustion chamber and subsequent gas leak towards gas turbine high temperature zone. A reliable readout configuration of such sensors may improve the system overall safety too. In this paper the authors discuss about the best thermoelements configurations in order to improve the reliability and serviceability performance in gas turbine in order to increase the system efficiency during power generation.

## 1 INTRODUCTION

In recent years researchers focussed part of the research efforts on power generation efficiency measurement due to the fact that traditional and renewable power sources have to be qualified not only in terms of power quality and stability but also in terms of overall system serviceability.

Therefore the efficiency of a power generation site has been enhanced through the vision that higher efficiency can be achieved through a life extension of power generators parts. Modular (mixed) generation sites where green power stations coexist aside with traditional generation structures based on gas turbine, for example, require outstanding reliability and availability figures to supply power baseline and power peak to the end users. Actually reliability plays an important role to grant a power plant capability and production over time while the availability figures are used to estimate the plant structure to arrange possible plant redundancies and maintenance. Some authors have extensively studied both reliability and availability of components up to complex equipment to evaluate the impact of aging on subsystem or system operating in a power generation plant (Hua and Yang, 2011); (Mugnaini et al., 2002); (Chowdhury and Koval, 2009);

(Ceschini et al., 2002). Traditional approached exploit reliability block diagrams representations, fault tree analysis (FTA) and homogeneous Markov Modelling (MM) (Rao, 2005); (Biolini, 2010). Out of these studies it is pointed out that even small components failures like the ones which can take place at sensor levels like the ones used for lube oil temperature read out purposes or accelerometrics sensors in journal bearing vibration monitoring can lead to meaningful failure of huge parts of the production site, with the consequent impossibility to grant the nominal station power generation. Usually, such studies are performed taking into account constant failure and repair rates, because this allows an easier formulation and modelling of the problem.

Some efforts (Mugnaini et al., 2002); (Fort et al., 2013) have been done in order to improve the modelling of the components failure rates representation. For example dynamic changes of failure rates over time allows to be more adherent to real mission behaviour. Such researches proved that this approach is effective with promising results but its implementation on complex structure may require an extensive effort for data collection and synthesis.

Some of the parts that have an impact on system productivity reliability and safety are the thermoelements used in gas turbine exhaust for

temperature monitoring (Fort et al., 2013); (Catelani et al., 2000); (Catelani et al., 2007). Such sensors are widely exploited to monitor indirectly the behaviour of the combustion of the gas turbine and to check the temperature distribution on the high pressure wheel to extrapolate information on the gas turbine efficiency and on possible components thermal stress. Unfortunately designers somehow don't take into consideration the impact of the sensor number connected to the trip and control logics configuration in assigning to a specific gas turbine a certain number of thermoelements. This work aims in providing an analysis on how a selected number of different sensors configurations may present reliability and serviceability differences which can affect the overall system reliability and availability.

## 2 SYSTEM DESCRIPTION

The gas turbine exhaust temperature is monitored through a certain number of thermoelements (generally thermocouples) in order to provide indication on the combustion gas temperature distribution as well as on the combustion chamber and liner performance.

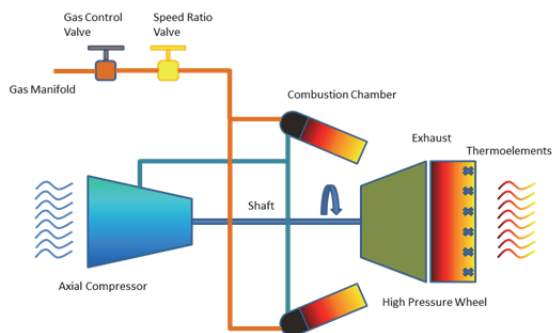

Figure 1: Simplified schematic of a gas turbine system transversal section.

In Figure 1 a simplified schematic of a gas turbine system transversal section is presented. It is possible to identify the main gas manifold which provides the system with the gas to be burned the combustion chambers which are roundly and symmetrically distributed around the gas turbine, a couple of gas valves named gas control valve which provides the main gas flow and the speed ration valve used to control the main wheel speed rotation respectively, the axial compressor which feeds with compressed air the combustion chamber, the high pressure wheel and the exhaust. Thermoelements for temperature monitoring are usually placed on the

exhaust middle section on a radial geometry in order to grant the combustion chamber uniformity monitoring and complete mapping. Such sensors can be either thermocouples or negative temperature coefficient sensors dependently by the specific turbine designer.

The aim of such sensor is to monitor the temperature distribution of the exhaust and to support in the diagnosis of anomalous conditions like combustion malfunction in one of the chambers with alarm or trip (stop) signals. Of course in case of failure of one sensor it is barely unlikely to stop the whole machine comparing the cost versus the benefits of the operation. Nevertheless more than one failure can induce a machine trip but this has to be justified by a proper reliability/availability analysis.

The number of sensors that are generally present for temperature monitoring should take into account at least three factors: the reliability impact of the configuration according to the selected alarm/trip logic, the availability considerations and the overall system safety apportionment.

## 3 RELIABILITY AND AVAILABILITY MODELING

Reliability  $R(t)$  techniques exploit reliability block diagram modelling (RBD) (Mugnaini et al., 2002) while availability  $A(t)$  approaches relying on homogeneous Markov Modelling (flow state space) are preferred when dealing with constant failure and repair rates (Rao, 2005); (Birolini, 2010). With respect to reliability studies the presented paper will discuss about the figures of three different configurations taking into account six thermoelements, nominally identical, with a constant failure rate according to Table 1.

Table 1: Single thermoelement failure rate.

Failure Rate	[Failures/h]
$\lambda$	$0.1 \cdot 10^{-6}$

The purpose is to evaluate which is the configuration that best fits a new product application on the reliability standpoint considering also the availability, serviceability and safety aspects.

The configurations that will be considered are a 2oo6 that means that at least two thermoelement over six have to be working to let the system accomplish its mission, the 4oo6 configuration where at least four element have to work and an hybrid configuration of 3oo6 plus two consecutive

failure. This latter in particular consider that in order to declare a system failure and therefore a system trip, 4 or more thermoelements should fail or two consecutive elements should fail. This additional condition takes into consideration that fact that in order to consider the system safety the temperature control over a large section of the exhaust should not be lost. The system RBD is represented in Figure 2 where on the upper part there are the odd thermoelements while in the lower part there are the even ones.

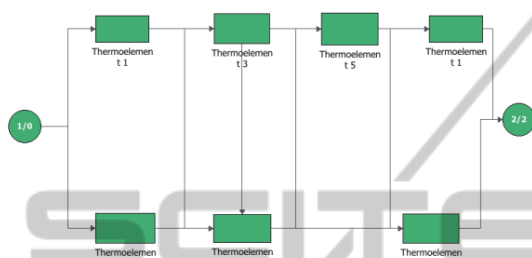

Figure 2: Reliability Block Diagram (RBD) of a 3oo6 +2 consecutive failures configuration.

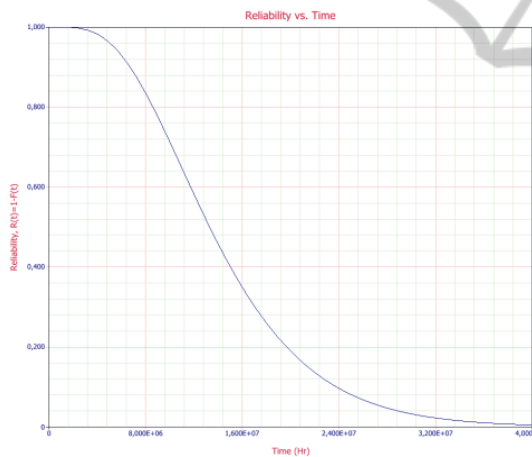

Figure 3: Reliability behaviour of a 2oo6 configuration with  $\lambda=0.1e-6$  F/h and  $\mu=0$ .

In Figure 3 there's the reliability behaviour over time of the 2oo6 configuration, while in Figure 4 and Figure 5 there are the reliability results of the 4oo6 and 3oo6 plus 2 consecutive failures respectively. It is possible to notice that as could be expected the 2oo6 configuration has the highest reliability degree but unfortunately such configuration does not allow to keep a satisfying exhaust temperature control. On the opposite site the behaviour of Figure 5 is very conservative because the reliability behaviour is not only far below the one of the other two configurations but also the slope on the first part of the curve is very high

(negative slope) denoting a high change rate in the reliability of the system in the first part of its mission.

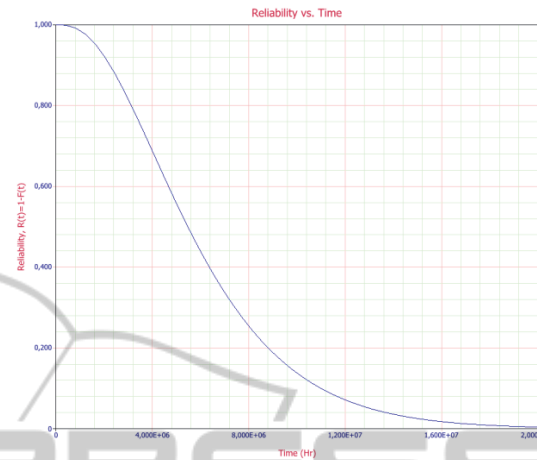

Figure 4: Reliability behaviour of a 4oo6 configuration with  $\lambda=0.1e-6$  failures/h and  $\mu=0$ .

Of course this is the effect of the combination of the safety requirement (2 consecutive thermoelements monitoring). Therefore, a good compromise among the three configurations could be represented by the 4oo6 placement where a reasonable reliability and system special covering can be granted at the same time.

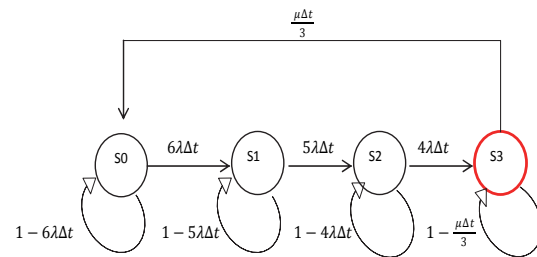

Figure 5: Reliability behaviour of a 3oo6 +2 consecutive failures configuration with  $\lambda=0.1e-6$  failures/h and  $\mu=0$ .

We introduce now the availability analysis through MM to evaluate such configurations enhancing the study with the availability considerations (Rao, 2005), (Biolini, 2010). It is common to find actual field situations where a system can be described or condensed as a block with certain properties in terms of failure rate ( $\lambda$  [failures/h]) and repair rate ( $\mu$  [repairs/h]). For such systems it is possible then to build specific Markov models and solve them in terms of their availability, based on the following basics (but not limited) assumptions depending on the operability conditions assumed and on the number of states selected.

1. There are  $N$  observable states
2. There is an observable sequence  $q_1, q_2, \dots, q_T$
3. The failure and repair rates are constants over time (memory less condition) and the process is stationary
4. Each transition from one state to the other take place in defined  $\Delta t$  which is constant (sampling time)
5. In each  $\Delta t$  only one transition take place
6. Every  $\Delta t$  a transition should occur.
7. First order Markov assumption

For such modelling the authors decided to modify to the 2003 configuration adding the constraints of the three consecutive failed items to include safety monitoring aspects in such representation. Therefore we studied the three most promising configurations (4006, 3006+2consecutive and 2006+3 consecutive) from an availability perspective. We represented the state flow diagram as in Figure 6 where  $S_X$  is a specific transition state corresponding to a physical sensing arrangement behaviour while one state, the red one, represents the system failure condition. Each transition taking place every sampling time is associate with a probability through the failure and repair rates. The system dynamics can be expressed through (1):

$$\frac{dP(t)}{dt} = \begin{pmatrix} -6\lambda & 0 & 0 & \frac{\mu}{3} \\ 6\lambda & -5\lambda & 0 & 0 \\ 0 & 5\lambda & -4\lambda & 0 \\ 0 & 0 & 4\lambda & -\frac{\mu}{3} \end{pmatrix} P(t) \quad (1)$$

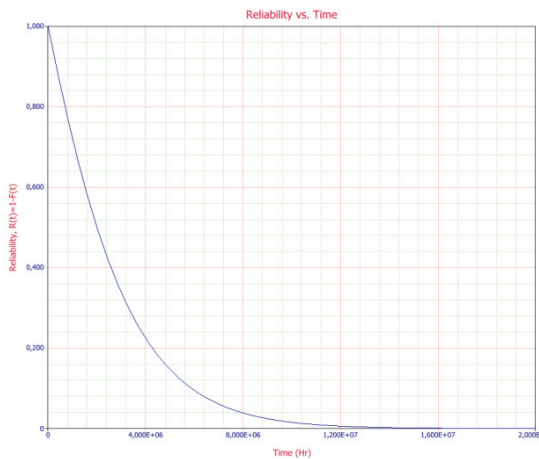

Figure 6: State space representation of the MM of the 4006 configuration where S3 represents the failed case.

The availability performance can be measured through the sum of the probabilities over time of the states that are not considered failed and the

analytical solution can be obtained. In the same manner in Figure 7 and 8 there are the modeling of the two alternative configurations that is the 2006 + 3 consecutive and the 3006 + 2 consecutive failures respectively, while (2) and (3) describe again the system dynamics.

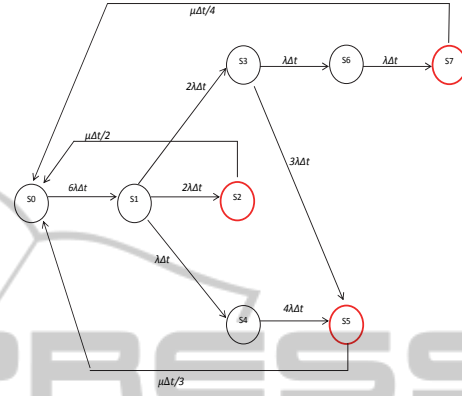

Figure 7: State space representation of the MM of the 3006 + 2 consecutive failures configuration where S2, S5 and S7 represent the failed cases.

Such matrices are usually sparse due to the fact that the system is not repaired until a meaningful number of failed items are present. This assumption is reasonable considering the cost of the single item with respect to a forced stop of power plants.

$$\frac{dP(t)}{dt} = \begin{pmatrix} -6\lambda & 0 & \frac{\mu}{2} & 0 & 0 & \frac{\mu}{3} & 0 & \frac{\mu}{4} \\ 6\lambda & -5\lambda & 0 & 0 & 0 & 0 & 0 & 0 \\ 0 & 2\lambda & -\frac{\mu}{2} & 0 & 0 & 0 & 0 & 0 \\ 0 & 2\lambda & 0 & -4\lambda & 0 & 0 & 0 & 0 \\ 0 & \lambda & 0 & 0 & -4\lambda & 0 & 0 & 0 \\ 0 & 0 & 0 & 3\lambda & 4\lambda & -\frac{\mu}{3} & 0 & 0 \\ 0 & 0 & 0 & \lambda & 0 & 0 & -\lambda & 0 \\ 0 & 0 & 0 & 0 & 0 & 0 & \lambda & -\frac{\mu}{4} \end{pmatrix} P(t) \quad (2)$$

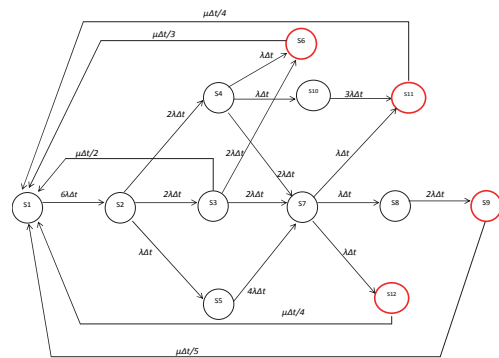

Figure 8: State space representation of the MM of the 2006 + 3 consecutive failures configuration where S6, S9, S11 and S12 represent the failed cases.

$$\left( \begin{array}{cccccccccccc} -6\lambda & 0 & 0 & 0 & 0 & \frac{\mu}{3} & 0 & 0 & 0 & \frac{\mu}{4} & 0 & \frac{\mu}{4} \\ 6\lambda & -5\lambda & 0 & 0 & 0 & 0 & 0 & 0 & 0 & 0 & 0 & 0 \\ 0 & 2\lambda & -4\mu & 0 & 0 & 0 & 0 & 0 & 0 & 0 & 0 & 0 \\ 0 & 2\lambda & 0 & -4\lambda & 0 & 0 & 0 & 0 & 0 & 0 & 0 & 0 \\ 0 & \lambda & 0 & 0 & -4\lambda & 0 & 0 & 0 & 0 & 0 & 0 & 0 \\ 0 & 0 & 2\lambda & \lambda & 0 & -\frac{\mu}{3} & 0 & 0 & 0 & 0 & 0 & 0 \\ 0 & 0 & 2\lambda & 2\lambda & 4\lambda & 0 & -3\lambda & 0 & 0 & 0 & 0 & 0 \\ 0 & 0 & 0 & 0 & 0 & 0 & \lambda & -2\lambda & 0 & 0 & 0 & 0 \\ 0 & 0 & 0 & 0 & 0 & 0 & 0 & 2\lambda & -\frac{\mu}{4} & 0 & 0 & 0 \\ 0 & 0 & 0 & \lambda & 0 & 0 & 0 & 0 & 0 & -3\lambda & 0 & 0 \\ 0 & 0 & 0 & 0 & 0 & 0 & \lambda & 0 & 0 & 3\lambda & -\frac{\mu}{4} & 0 \\ 0 & 0 & 0 & 0 & 0 & 0 & \lambda & 0 & 0 & 0 & 0 & -\frac{\mu}{4} \end{array} \right) P(t) \quad (3)$$

In Figure 9 the comparison among the availability simulations of the three mentioned configurations supposing to have a repair rate of 1/48 [1/h] is sketched.

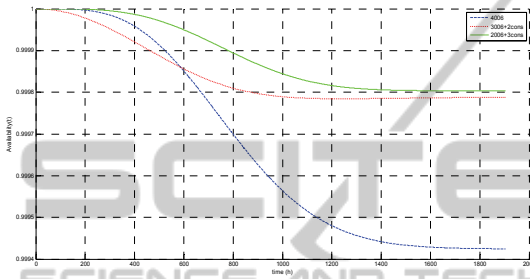

Figure 9: Availability comparison of the three configurations considering 48h as the inverse of the repair rate  $\mu$ .

Out of the analysis it is evident that the best configuration representing a reasonable choice among the three proposed is the 2006 + 3 consecutive failures due to the fact that it shows the best steady state availability behaviour.

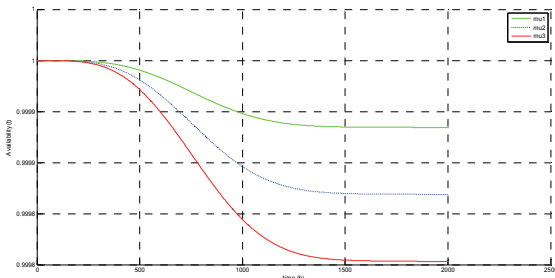

Figure 10: Availability behaviour of the 2003+3 consecutive failures configuration considering 16, 32 and 48h as the inverses of three different repair rates  $\mu$ .

Availability modification according to different repair rates (16, 32 and 48 hours respectively) are investigated and results are shown in Figure 10.

### 4 CONCLUSIONS

In this paper the authors propose three different configurations to evaluate the reliability and

availability of the disposition of six thermoelements used to monitor the exhaust temperature in a gas turbine system to enhance system productivity and efficiency performance over time. The study has been performed exploiting both RBD and Markov state flow modelling under the hypothesis of constant failure and repair rates. Results pointed out that the best configuration is the 2006 + 3 consecutive both in terms of reliability and availability.

### REFERENCES

Hua D., Yang X. H., 2011, Reliability Analysis of Gas Turbine Based on the Failure Mode and Effect Analysis *Power and Energy Engineering Conference (APPEEC), Asia-Pacific*.

Mugnaini M., Catelani M., Ceschini G., Masi A., Nocentini F., 2002, Pseudo Time-Variant parameters in centrifugal compressor availability studies by means of Markov models in *Microelectronics Reliability*, vol. 42, p. 1373-1376, ISSN: 0026-2714.

Chowdhury, A. A., Koval, D. O. 2009, Reliability Assessment of a Backup Gas Turbine Generation System for a Critical Industry Load Using a Monte Carlo Simulation *Model Industry Applications, IEEE Transactions on Volume:45, Issue : 1 10.1109/TIA.2008.2009495, Page(s): 310 – 316*.

Ceschini G., Mugnaini M., Masi A., 2002, A reliability study for a submarine compression application *Microelectronics Reliability*, vol. 42, p. 1377-1380, issn: 0026-2714.

Rao S. S., 2005, Reliability engineering Design *McGraw Hill*.

Biolini A., 2010, Reliability Engineering: Theory and Practice *Springer 6th Edition 2010*.

Fort A., Bertocci F., Mugnaini M., Vignoli V., Gaggi V., Galasso A., Pieralli M., 2013, Availability modeling of a safe communication system for rolling stock applications *Conference Record - IEEE Instrumentation and Measurement Technology Conference*, art. no. 6555453, pp. 427-430.

Catelani M., Mugnaini M., Singuaroli R., 2000, Effects of test sequences on the degradation analysis in high speed connectors *Microelectronics Reliability*, vol. 40, p. 1461-1465, ISSN:0026-2714.

Catelani M., Ciani L., Mugnaini M., Scarano V., Singuaroli R., 2007, Definition of safety levels and performances of safety: Applications for an electronic equipment used on rolling stock *IEEE Instrumentation and Measurement Technology Conference*, art. no. 4258348, IMTC.