

Simultaneous Design of Structural and Control Systems using Set-based Design Method

Haruo Ishikawa¹ and Naoko Sasaki²

¹Graduate School of Informatics and Engineering, The University of Electro-Communications, Chofu, Tokyo, Japan

²Center for International Programs and Exchange, The University of Electro-Communications, Chofu, Tokyo, Japan

Keywords: Simultaneous Design, Structural System, Control System, Set-based Design.

Abstract: The design method capable of considering the influence factors related to control and structural design systems under conditions that simultaneously satisfy multi-objective performances over both the systems is investigated. The influence factors and performances have some kinds of uncertainty related to structural design and control system design. The uncertainty may be expressed in terms of set interval. Set-based design method is available as a design method that can take account of such uncertainty. In the method, instead of optimization, the concept of satisficing is used. In the present study, the applicability of set-based design method that has been studied in the field of structural design is investigated for the simultaneously satisficing design of control and structural systems. For discussing the applicability, an example problem of inverted pendulum with heteromorphic shape on cart is solved by optimal regulator method in modern control theory. As a result, the set intervals of influence factors which simultaneously satisfy the set intervals of multi-objective performances are obtained. From this result, the usefulness of set-based design method for simultaneous design of control and structural systems can be confirmed.

1 INTRODUCTION

In the development of mechanical/structural system, control function plays a great role in the system, and optimal design of control system and structural system that have deep interaction with each other is considered to be of great importance. Therefore, in product development, the simultaneity of optimum design of both systems is indispensable from the viewpoints of realization of better product performances, short lead time and low cost for the development of product (Mehra, R.K., 1976; Kubrusly C.S. et al, 1985; Kabamba P.T. et al, 1983; Soong, T.T., 1990). Main previous studies have treated with mathematical optimization or coupled computation by CAE which are based on point-based calculation. The simultaneous optimization problems have often been formulated for the relatively simple cases, as the mathematical minimization/maximization problem of evaluation function (Kajiwara, I., 1994, Hara, F., 1992, Hatano, H., 1993, Khot, N.S. et al, 1993, Nahm, Y. -E. and Ishikawa, H., 2006). Generally speaking, in some practical cases (Nakaminami, M., et al, 2007), specified control target objects (structures) were

designed in advance, and in the other cases, in addition to the characteristics of control system, weight or damped oscillation characteristics that is a factor governing the characteristics of structures is considered later (Obinata, G., 1997). However, in general, physical mechanisms of the mutual interaction of both systems of structure and control are still remained obscure. There are various issues to be considered, such as types and number of design variables, structural and control characteristics of product, a large number of restrictions for design, meta model relating design variables and characteristics of product, complexity and multi-peak solutions of evaluation function, and dynamic characteristics governed by motion equation with a large number of freedom that affects the interaction and so on. Due to the complexity of the problems, in the simultaneous design problem of the structural and control systems, a large number of design factors simultaneously satisfying multiple conditions should be obtained. Conventionally, practical design methodology for such situation has been based on the point-based repetition design procedure.

On the other hand, it is general and essential that the required performances and the influence factors for them have some kinds of uncertainty. Uncertainty especially in the initial stage of structural design is based on imperfections of related knowledge, influences from other design sectors or customers and so on. In control design, there is essential uncertainty due to the difference between structural model and mathematical model for control. In case of classical control design, as the typical example of uncertainty of control design, it can be said that feedback gains, like proportional gain, integral gain and derivative gain, have uncertainty in PID feedback control. The values of these gains can be independently given for control object, and it is necessary for each gain to determine an optimum value that represents good performance regarding stability of control. Namely, the gains are adjustment factors. Also, in modern control theory, for examples, turn over design method has the variation in the position of folding line by which response characteristics of control change and optimum regulator control method has the variation in the values of diagonal terms of weight matrix of evaluation function to realize high stability of control. Actually, the position of folding line in the former example and the values of diagonal terms in the latter example are decided by trial and error. Then, these variations can be regarded as certain kind of uncertainty.

In this research, for the expression of the uncertainty, we use aggregate-based method rather than point-based method. Also, as stated above, the design system is often multi-objective, whether structural system or control system. In the design of structure (machine) system, there are multi-objectives, like rigidity, strength, light weight, compactness, cost, impact on environmental burden, velocity, accurate positioning, Kansei performance like comfort and so on. In case of control design systems, generally, there are plural performances of control stability, like rising time, maximum overshoot rate, settling time and so on. Then, it is important to investigate the simultaneously satisficing multi-objective design problem in consideration of uncertainty.

On the other hand, set-based design method has been studied as the simultaneously satisficing method for multi-objective design considering the uncertainty in structural (mechanical) design field (Nahm, Y. -E. and Ishikawa, H., 2005, Nahm, Y. -E. and Ishikawa, H., 2006, Nahm, Y. -E. and Ishikawa, H., et al, 2006.). In the present study, PSD (Preference Set-Based Design) method that is one of

the set-based design methods is used. The concept of preference that is given by designer is used to find subsets that show higher satisfaction and robustness of solutions. In the present study, the applicability or potential of PSD method is studied by using an example problem which is a virtual inverted pendulum with non-uniform shape on cart. This problem is solved by optimal regulator formulation in modern control theory. The inverted pendulum with non-uniform shape (the size is change) and holes in the inside is adopted to emphasize the structural factors of the design. Depending on these factors, the position of the moment of inertia of pendulum which is one of the control factors varies. In other words, it can be said that the simultaneous design problem like this time implies the design of structural system (mechanical system) that realizes the performances of control system. In this problem, five design variables related to structural and control systems are adopted. Three of them are structural variables and two are control related variables. Two performance objectives such as transient characteristic of control (settling time) and lightweight of structure are adopted.

In this research, MATLAB is used for simulation of control system design (MATLAB is registered trade mark of MathWorks, USA).

2 PREFERENCE SET-BASED DESIGN (PSD METHOD)

“Preference” is attached to the name of the method because “preference” includes one of the basic concepts of the method. The outline of PSD method is shown below.

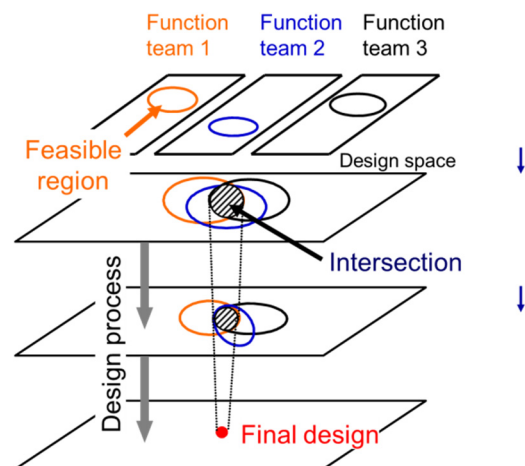

Figure 1: Concept of preference set-based design method.

The PSD method consists of (1) set representation, (2) set propagation and (3) set narrowing. These concepts of the PSD method are represented as the different layers in Figure 1, respectively. Also, the procedure of the method is illustrated in Figure 2. In this study, the solution space for structural requirements and control design performances are aligned and a final narrowed interval set of design solution is identified. In the process, instead of the elimination of those uncertainties by repeatedly correcting point values of adjustment parameters, in the present study, preference set-based design method is used. That is, set solution candidates are evaluated by the concept of satisfaction and robustness defined by set interval with preference and the subspace of low evaluation is eliminated. Each process of PSD method, shown in Figure 2, is as follows;

- (1) The set representation is to express uncertainty and variability of performances and design variables in terms of set concept.
- (2) The set propagation means the set mapping of design variables to performance set, based on the relationship (equation of theory, numerical calculation or experiment) between design variables and performances.
- (3) In the set narrowing, first, overlap region between the mapped result and the initially set of performance is obtained. Next, the common set of the overlap region for each performance is found. Finally, this approach narrows the common set of design variables by eliminating infeasible design subspaces by using the concept of satisfaction and robustness. A detailed description of the PSD method can be found in references (Nahm, Y. -E. and Ishikawa, H., 2005; Nahm, Y. -E. and Ishikawa, H., 2006).

3 SIMULTANEOUS DESIGN OF STRUCTURAL AND CONTROL SYSTEMS

An example problem of PSD method for the simultaneous design of structural and control systems is virtual problem of inverted pendulum on cart, shown in Figure 3. The pendulum has non-uniform (step type) outline shape with internal holes as structural factors. That is, the outer shape and dimensions of the pendulum, and the number of holes are design variables. In other words, it can also be said that the design problem of the shape and

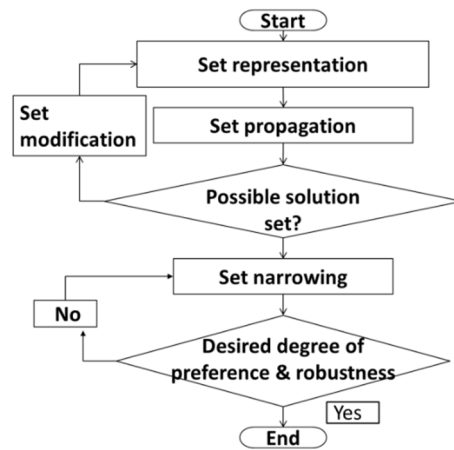

Figure 2: Procedure of preference set-based design method.

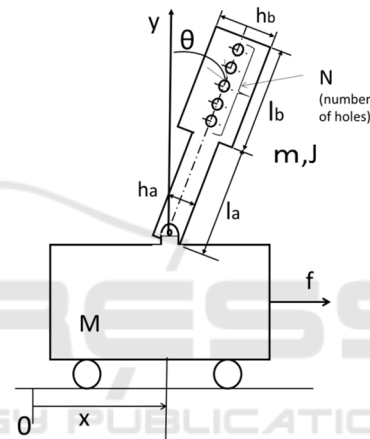

Figure 3: A virtual example problem of inverted pendulum on cart.

dimensions of pendulum is a problem of obtaining structure design solution that realizes the control performance of pendulum on cart. Although this problem is certainly not a realistic issue, it is suitable for examining the usefulness of the method. There has been no trial of application of concept and approach of set-based design method to control system design itself and simultaneous design of control and structural systems, the present study is the first one.

By the linearization of the equations of motion of pendulum and cart around a certain value of rotation ($\theta=0$) of pendulum, the equations are given as follows,

$$\left. \begin{aligned} ml\ddot{x} + (J+ml^2)\ddot{\theta} - mg\theta &= 0 \\ (M+m)\ddot{x} + ml\ddot{\theta} &= f \end{aligned} \right\} \quad (1)$$

where M, x and f are mass, position and driven force of cart, respectively, and m, l, J, θ and g are mass,

length from rotation fulcrum to centroid of pendulum, rotation angle of pendulum and gravitational acceleration, respectively. Mathematical model given by equation (1) is expressed as state equations (2) and (3).

$$\dot{x} = Ax + Bu \tag{2}$$

$$x = [\theta \ x \ \dot{\theta} \ \dot{x}]^T \tag{3}$$

where A and B are matrix of 4 row by 4 column and matrix of 4 row by 1 column, respectively. In the present problem, mathematical model given by equation (2) has controllability and observability. Then, the concept of state feedback control and its formulation of optimal regulator are applicable to the inverted pendulum problem on cart which is inherently unstable control system. Conceptual diagram of optimum regulator system is shown in Figure 4. In Figure 4, K is state feedback gain matrix. According to the optimal regulator method, optimal control input that minimizes evaluation function can be obtained. The evaluation function is given by

$$J = (1/2) \int_0^{\infty} \{x^T(t)Qx(t) + Ru^2(t)\} dt \tag{4}$$

In equation (4), Q and R are weighting factor matrices which are given by the equations,

$$Q = \begin{bmatrix} q1 & 0 & 0 & 0 \\ 0 & q1 & 0 & 0 \\ 0 & 0 & q1 & 0 \\ 0 & 0 & 0 & q1 \end{bmatrix} \quad R = [r1] \tag{5}$$

Here, diagonal terms of diagonal matrix, Q, are assumed to be equal.

Weighting factor matrices, Q and R, are currently determined by trial and error, because the relationship between the weighting factors, Q and R, and the response of control has not been elucidated. That means they cannot be definitely determined as point values at the beginning of control design. That is, they have each fluctuation range, because they are independent each other.

By solving Riccati algebraic equation under the provisional values of Q and R, it is possible to obtain the response of closed loop system under initially given position value of cart.

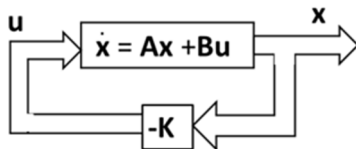

Figure 4: Optimum regulator system.

4 APPLICATION RESULTS

The preference set-based design was carried out using the initial sets of five design variables and two kinds of performances (settling time on stability of pendulum and lightweight of structure). The settling time is defined as the time when the swing angle of pendulum falls within ±0.01 (rad). Among the five design variables, three are structural variables, the length l_b and width h_b of the upper part of pendulum and the discrete number n of holes in the pendulum, shown in Figure 3. The diameter of hole is fixed as $\phi=0.04$ (M). The remaining two are control system variables that are the weighting factors of evaluation function (diagonal matrix), Q and R in equation (4). Thus, their diagonal terms, $q1$ and $r1$ in equation (5) are also design variables. The length l_a and width h_a of the lower part of pendulum are fixed as $l_a=0.2$ (M) and $h_a=0.06$ (M).

Using the initial interval sets of the design variables and required performances, shown in Table 1, the procedure of PSD method in Figure 2 is applied. Table 2 shows that all the design variables are narrowed so as to realize the set range of two performances which simultaneously satisfy the narrowed performances. This can be understood from the algorithm of PSD method. As an example of concrete results, the interval set of the discrete number of holes, shown in the first row of Table 2, is narrowed from the interval set, [2, 9], to the interval set, [7, 9].

Table 1: The initial interval sets of design variables and required performances.

Design variables

n	[2, 9]
l_b	[0.5, 0.8] (M)
h_b	[0.06, 0.2] (M)
Q($q1$)	[1, 9]
R($r1$)	[0.1, 1.5]

Required performances

settling time, T_s	≤ 3.5 (sec)
mass, m	≤ 0.12 (kg)

Table 2: Narrowed set of design variables and performance variables.

Design variables	
n	[7, 9]
l_b	[0.650, 0.725] (M)
h_b	[0.130, 0.165] (M)
$Q(q1)$	[7, 9]
$R(r1)$	[1.15, 1.5]
Required performances	
settling time, T_s	[3.485, 3.50] (sec)
mass, m	[0.073, 0.111] (kg)

5 CONCLUSION

Various kinds of variables related to structural design and control design have uncertainty, such as lack of knowledge, influence from other sector or customer, certain weight factor to be subjectively determined and so on. In the present study, the uncertainty is expressed by set interval. Then, the uncertainty of design can also be considered as adjustment factor. In the present study, the set-based design method capable of considering the uncertainties related to the state feedback controller in control system design and the shape/size of controlled object in structural system design at the same time and satisfying the multiple design objects as well is investigated. The design method is different from the traditional point-based design method. In PSD (Preference Set-based Design) method which is one of the set-based design method, the design variables and performance variables are represented by interval set and solution sets of multi-objective performances can be obtained considering subspaces with higher satisfaction and robustness of required performances.

In order to consider the applicability of PSD method, a virtual inverted pendulum problem on cart controlled by optimum regulator method in modern control theory is studied. In the example problem, five design variables (three and two design variables for structural system and control system, respectively), and two required performances (one is performance for structural system and another for control system) are selected. As a result of the application, the effectiveness of PSD method could be confirmed.

6 FUTURE WORK

Future study based on set-based design method can be expected from various viewpoints including the application of other control theory. For example, turn over design method in modern control theory has the variation in the position of folding line. By using the position as a design variable, it is possible to appropriately select pole placement that desires transient characteristics. Based on these control theories, simultaneous design of control and structural systems will be discussed. Although not discussed in this paper, we will consider the influence of fluctuation of the preference in the PSD method on the results of interval set solutions.

REFERENCES

- Hara, F., 1992. Optimization of pipe-support allocation by neural network, *The Japan Society of Mechanical Engineers*, (C)58-550, pp. 1728-1734. (in Japanese)
- Hatano, H., 1993. Optimization by GA, *Journal of the Society of Instrument and Control Engineers*, 32-1, pp. 52-57. (in Japanese)
- Kubrusly, C. S., Malebranche, H., 1985. Sensors and controllers location in distributed systems-A survey, *Automatica*, 21-2, pp. 117-128.
- Kabamba P.T., Longman, R.W., 1983. An integrated approach to reduced-order control theory, *Optimal Control Applications & Methods*, 4, pp. 405-415.
- Kajiwara, I., Nagamatsu, A., 1994. Optimum design of structure and control systems by modal analysis, *The Japan Society of Mechanical Engineers*, (C)60-570, pp.368-373. (in Japanese)
- Khot, N. S., Öz, H., 1993. Structural-control optimization with H2 and H constraints, *34th SDM (Structures, Structural Dynamics and Materials) Conference*, AIAA-93-1470-CP, pp.1429-1437.
- Mehra, R. K., 1976. Optimization of measurement schedules and sensor designs for linear dynamic systems," *IEEE Trans.*, AC-21-1, pp. 55-64.
- Nahm, Y. -E., Ishikawa, H., 2005. Representing and Aggregating Engineering Quantities with Preference Structure for Set-based Concurrent Engineering, *Concurrent Engineering: Research and Applications*, 13, 2, pp. 123-133.
- Nahm, Y.-E. Ishikawa, H., 2006. Novel space-based design methodology for preliminary engineering design, *International Advancement Technology*, 28, pp.1056-1070.
- Nahm, Y. -E., Ishikawa, H., et al., 2006. Set-based multi-objective design optimization (2nd report), *Transactions of the Society of Automotive Engineers of Japan*, 36-6, pp.163-168. (in Japanese)
- Nakaminami, M., Tokuma, T., et al, 2007. Optimal structure design methodology for compound multi-axis

machine tools—Analysis of requirement and specifications—, *Int. J. of Automation Technology*, 1-2, pp. 78-86.

Obinata, G., 1997. Simultaneous optimal design of structural system and control system, *Journal of the Society of Instrument and Control Engineers*, 36, 4, pp. 254-261. (in Japanese)

Soong, T. T., 1990. *Active structural control*, John Wiley & son.

