

# Experimental Study on Riprap Layer Design for Circular Bridge Pier

Efferiki<sup>a</sup>, Robby Yussac Tallar<sup>b</sup> and Alexander Yovan Suwono<sup>c</sup>

Civil Engineering Department, Maranatha Christian University, Jl. Surya Sumantri 65, Bandung, Jawa Barat, Indonesia

Keywords: Circular Bride Pier, Riprap Layer Design, Local Scour.

Abstract: Scouring is a natural phenomenon that often occurs in streams. Scouring can also occur locally if there are any changes in streams such as structural components within. A review of the literature has been accomplished to investigate the previous results of the effectiveness of riprap design. However, few studies were focused on the position of riprap layer design. Therefore, the main purpose of this study is to compare the effectiveness of riprap layer design for circular bridge pier by experimental study. Several scenarios have been set up by compared two layers conditions (the lower and upper sediment-based riprap layer design). The flow sediment condition used in this research is clear water condition. The stable riprap size and the optimized extension of the riprap layer around the circular pier along the flow direction were studied experimentally. The result indicates that the lower sediment-based riprap layer design is  $\pm 10$  to 20% more effective compared to the upper sediment-based riprap layer design with different discharge flow scenarios. Further studies are also needed regarding the effect of riprap characteristics such as shape and diameter, variations of riprap thickness, and other related variables.

## 1 INTRODUCTION

Scouring is a natural phenomenon that often occurs in streams (Mashahir, Zarrati, & Mokallaf, 2010; Youssef, 2018). Scouring can also occur locally if there are any changes in streams such as structural components within (Tallar & Suen, 2015). Structural components will block water flow that creates horseshoe vortex system (Graf & Istiarto, 2002). This horseshoe vortex causes water level drops and called local scouring. Local scouring can be identified as an abrupt decline in bed level due to erosion of bed material by the local flow structure induced by obstruction such as bridge pier set in the river (Figure 1).

Bridge is one of the most common structural components built-in streams to connect two or more places (Chiew & Lim, 2000). Local Scouring may endanger the structural components of the bridge, especially bridge piers. These days, there are so many ways used to prevent local scouring. Riprap is a common structure used to protect pier and abutment of the bridge, stilling basin and other structures within stream being vulnerable to deteriorative erosion

caused by flow velocity (Lagasse, 2006). Riprap consists of stones that are installed in the bridge pier base. The reason why riprap is still commonly used to protect structural components, because it is easy to repair the riprap, and riprap construction does not cost much.

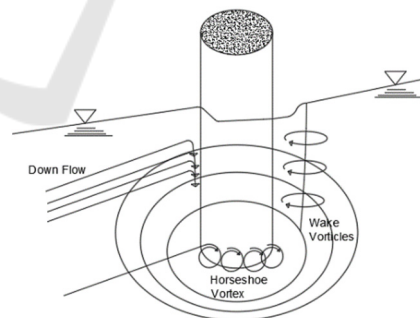

Figure 1: Local scouring at bridge pier.

A review of the literature has been accomplished to investigate the previous results of the effectiveness of riprap design (Tabarestani & Zarrati, 2013). However, few studies were focused on the position of riprap layer design. Some facts that happen in the

<sup>a</sup> <https://orcid.org/0000-0002-4408-6120>

<sup>b</sup> <https://orcid.org/0000-0001-7307-3348>

<sup>c</sup> <https://orcid.org/0000-0002-2577-8519>

field also show that riprap stones are carried away by streams. Therefore, the main purpose of this study is to compare the effectiveness of riprap layer design for circular bridge pier. The scope of this experimental study was performed in rectangular channel with clear-water condition.

## 2 METHODS

To study the effectiveness of riprap layer design, experimental research was carried out. This research used average discharge ( $Q_{50\%}$ ) and optimum discharge ( $Q_{75\%}$ ) to validate the results of this research. The parameter used to study the effectiveness of the riprap layer design was score depth and the stability of the riprap. The open channel was used in this research to determine the effectiveness of the riprap layer design.

### 2.1 Method for Discharge Analysis

To change the discharge of this experimental research, discharge rating curve was needed. Discharge data are important to determine the effectiveness of the riprap layer design modelled in this research. Discharge rating curve was drawn to determine  $Q_{50\%}$  and  $Q_{75\%}$ , which will be used in this research.

### 2.2 Method for Sieve Analysis

Sieve analysis was carried out to find the stone size of the riprap. the stone size of the riprap will be used as the control variable, so it is important to ensure that the stone size of every riprap used in this research is the same size which is average diameter ( $D_{r50}$ ). Sieve analysis was carried out by using a defined sieve. These sieves come with different opening size, to determine the stone grading.

### 2.3 Scenarios of Riprap Model

The first condition of this research used average discharge ( $Q_{50\%}$ ). Two scenarios were set up to determine the effectiveness of riprap layer design. The upper layer design was used in the first scenario and the lower layer design was used in the second scenario (Figure 2, 3, and 4). The thickness of the riprap layer, the size of the pier, the stone size of the riprap used as the control variable. The diameter of the pier used in this research is 8 cm and placed 120 cm from downstream of the weir. Based on previous

research, the thickness of the riprap layer used in this research was 2,5 cm.

The riprap was installed circular around the pier with a diameter of 28 cm. The second condition used  $Q_{75\%}$  to validate the first case. The scenarios and the control variable for the second condition were set up similar to the first condition.

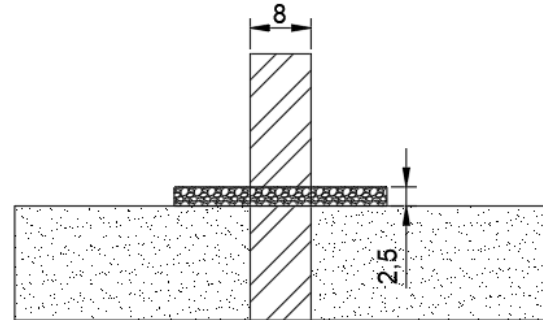

Figure 2: Side view of upper layer design.

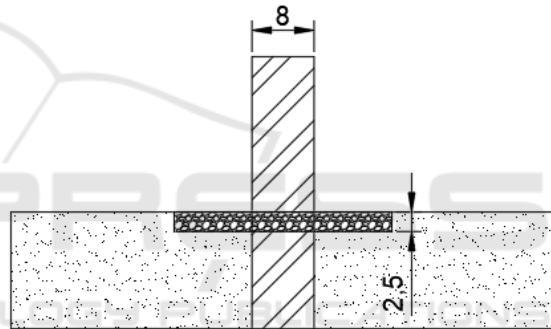

Figure 3: Side view of lower layer design.

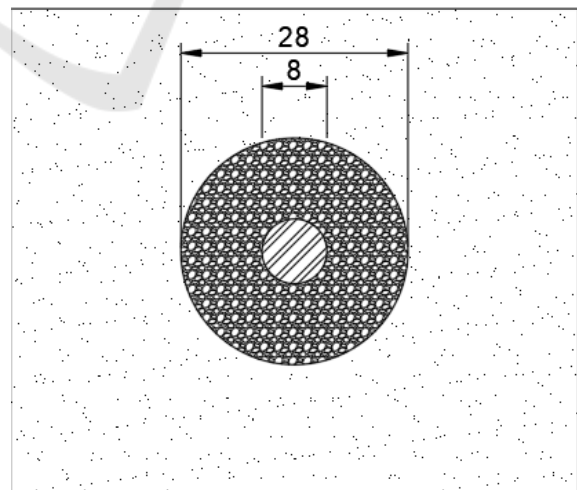

Figure 4: Top view of lower and upper layer design.

### 3 RESULTS AND DISCUSSION

#### 3.1 Discharge Analysis Result

From the experiment in the laboratory, discharge curve rating was drawn. After that, the  $Q_{50\%}$  and  $Q_{75\%}$  can be determined from the discharge curve rating (Figure 5).

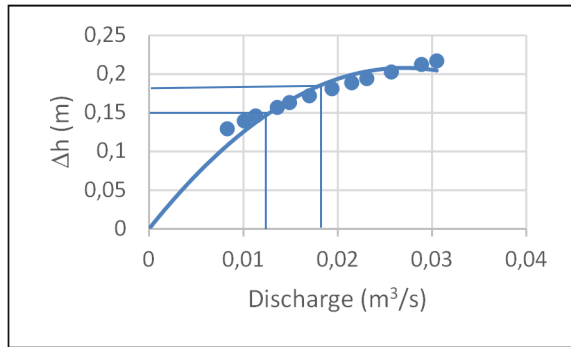

Figure 5: Discharge curve rating.

Based on the curve rating above, the value of  $Q_{50\%} = 0.0125 \text{ m}^3/\text{s}$ , and  $Q_{75\%} = 0.0188 \text{ m}^3/\text{s}$

#### 3.2 Sieve Analysis Result

From the sieve analysis experiment in the laboratory,  $Dr_{50}$  can be determined based on soil particle size distribution (Figure 6).

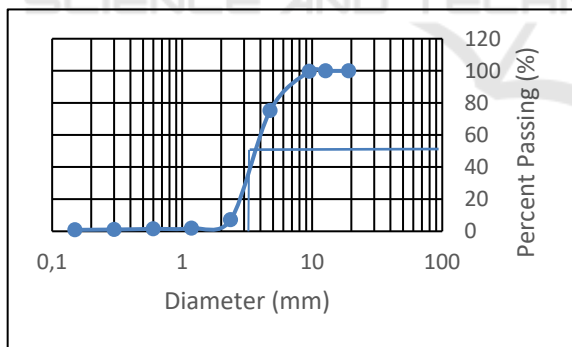

Figure 6: Soil particle distribution.

Based on the soil particle distribution above,  $Dr_{50}$  of the riprap stone is 3.8 mm.

#### 3.3 Riprap Model Result

After the discharge analysis and sieve analysis experiment, we can continue the research with riprap modelling. The effectiveness of riprap layer design is determined by the depth of scouring. The depth of scouring in the upper layer design was compared to

the depth of the scouring in the lower layer design. The result of the first condition of the riprap model using  $Q_{50\%}$  (Table 1):

Table 1: Result of the first condition of riprap model.

Scenario	Thickness of the riprap (mm)	Depth of Scouring $D_s$ (mm)
Upper layer	25	-11
Lower layer	25	-9

$$\begin{aligned}
 \text{Effectiveness} &= \left| \frac{d_{s1} - d_{s2}}{d_{s1}} \right| \times 100\% \\
 &= \left| \frac{-11 + 9}{-11} \right| \times 100\% \\
 &= 18.18\%
 \end{aligned}$$

The result of the second condition of the riprap model using  $Q_{75\%}$  (Table 2):

Table 2: Result of the second condition of riprap model.

Scenario	Thickness of the riprap (mm)	Depth of Scouring $D_s$ (mm)
Upper Layer	25	-21
Lower Layer	25	-18

$$\begin{aligned}
 \text{Effectiveness} &= \left| \frac{d_{s1} - d_{s2}}{d_{s1}} \right| \times 100\% \\
 &= \left| \frac{-21 + 18}{-21} \right| \times 100\% \\
 &= 14.29\%
 \end{aligned}$$

### 4 CONCLUSIONS

Based on the experiment, the result indicates that the lower sediment-based riprap layer design is  $\pm 10$  to 20% more effective compared to the upper sediment-based riprap layer design with different discharge flow conditions. With  $Q_{50\%}$  that was used in the first condition shows that the lower sediment-based riprap layer design is 18.18% more effective than the upper sediment-based riprap layer design. In the second condition, the lower sediment-based riprap layer design is 14.29% more effective than the upper sediment-based riprap layer design.

This research can be used to another structure components beside piers along the stream. Further studies are also needed regarding the effect of riprap characteristics such as shape and diameter, variations of riprap thickness, and other related variables.

## ACKNOWLEDGEMENTS

The authors gratefully appreciate the support from Civil Engineering Department, Maranatha Christian University, Indonesia.

## REFERENCES

- Chiew, Y.-M., & Lim, F.-H. (2000). Failure behavior of riprap layer at bridge piers under live-bed conditions. *Journal of Hydraulic Engineering*, 126(1), 43–55.
- Graf, W. H., & Istiarto, I. (2002). Flow pattern in the scour hole around a cylinder. *Journal of Hydraulic Research*, 40(1), 13–20.
- Lagasse, P. F. (2006). *Riprap design criteria, recommended specifications, and quality control* (Vol. 568). Transportation Research Board.
- Mashahir, M. B., Zarrati, A. R., & Mokallaf, E. (2010). Application of riprap and collar to prevent scouring around rectangular bridge piers. *Journal of Hydraulic Engineering*, 136(3), 183–187.
- Tabarestani, M. K., & Zarrati, A. R. (2013). Design of stable riprap around aligned and skewed rectangular bridge piers. *Journal of Hydraulic Engineering*, 139(8), 911–916.
- Tallar, R. Y., & Suen, J.-P. (2015). Identification of waterbody status in Indonesia by using predictive index assessment tool. *International Soil and Water Conservation Research*, 3(3), 224–238.
- Youssef, I. H. (2018). A novel method for riprap design of scour protection at bridge piers. *MOJ Civil Eng*, 4(2), 109–119.