





Modelling in GeoGebra in the Context of Holistic Approach Realization in Mathematical Training of Pre-service Specialists

Liudmyla I. Bilousova¹^a, Liudmyla E. Gryzun²^b, Svitlana H. Lytvynova³^c and Valentyna V. Pikalova^{4,1}^d

¹Kryvyi Rih State Pedagogical University, 54 Gagarin Ave., Kryvyi Rih, 50086, Ukraine

²Simon Kuznets Kharkiv National University of Economics, 9A Nauky Ave., Kharkiv, 61166, Ukraine

³Institute for Digitalisation of Education of the National Academy of Educational Sciences of Ukraine, 9 M. Berlynskoho Str., Kyiv, 04060, Ukraine

⁴National Technical University "Kharkiv Polytechnic Institute", 2 Kyrpychova Str., Kharkiv, 61002, Ukraine

Keywords: Modeling Activity on GeoGebra, Mathematical Training of Pre-service Specialists, Holistic Education, Computer Dynamic Model.

Abstract: In accordance with its aim, the article represents students' modeling activity (held within inter-university projects of Kharkiv GeoGebra Institute) which resulted in the complex of GeoGebra models focused on holistic learning of Mathematics at higher school and university. Proper theoretical background for the complex design is elaborated and the stages of the students' modeling activity are covered. The models in the developed complex are grouped in the three sections. The first group consists of the models which enable to facilitate mastering basic essential mathematical concepts (objects) by the potential trainees. The second group is focused on the realization of transdisciplinary connections between Mathematics and other subject domains. The third group embraces models which provide real-life problems solving based on the models investigation. All the groups are represented in the article along with specific examples of the models. In order to facilitate potential trainees' personal cognitive activity that is expected by holistic education, it was elaborated procedure of cognitive activity which includes some tips on changing the parameters of the dynamic model, monitoring the results, investigating, making conclusions etc. Such a procedure is aimed to streamline understanding the essence of the concept (phenomenon). The didactic support for each model was developed by the students to involve potential trainees into the solving special problems and real-life tasks which encourage them to obtain holistic understanding of the basic concepts via special cognitive activity based on work with dynamic models. The said didactic support is characterized in the paper. The prospects of further research are outlined.

1 INTRODUCTION

The analysis of the evidence of university and pre-university mathematics training as well as the results given in recent studies (Bobyliiev and Vihrova, 2021; Elkin et al., 2017; Semenikhina and Drushliak, 2014; Singh, 1996; Vlasenko et al., 2019), testify the number of drawbacks of contemporary school mathematics training which then lead to the difficulties faced by the university students and raise the problems of increasing the level of mathematical education both

at school and university.

According to the (Bevz, 2003; Bilousova et al., 2019; diSessa et al., 2004), the most common learning difficulties which brake the process of successful mastering mathematics are the following. Students find mathematical concept to be difficult to take in and to apply them properly to practical tasks. It leads to inability to achieve basic educational goals by the students which results in their losing interest to Mathematics. Finally, it becomes impossible for the students to see the beauty of the science and to appreciate its importance for mastering other knowledge domains.

One of the essential problems of mathematical training that can cause the learning difficulties is the absence of holistic understanding of mathematics as a

^a <https://orcid.org/0000-0002-2364-1885>

^b <https://orcid.org/0000-0002-5274-5624>

^c <https://orcid.org/0000-0002-5450-6635>

^d <https://orcid.org/0000-0002-0773-2947>

basis and tool for solving interdisciplinary tasks and real-life problems. Unfortunately, for the most of students, Mathematics remains too abstract curriculum subject which is really complicated and distracted from real world. Hence, the students are demotivated to master it and feel true necessity to its deep understanding.

The said problems of mathematical training which are faced nowadays by the pre-service specialists of different majors cause the necessity of finding and applying new approaches to mathematics learning. One of such approaches seems to be holistic educational paradigm which aims to provide dynamic, harmonized, and interconnected ways of learning.

According to the research on the holistic approach, the core concept of holistic education is the cohesive development of the students' personality both at the intellectual and emotional levels (Singh, 1996). In addition, it is underlined that the said cohesive progress should base on the links between real-life problems and personal experience of a trainee.

Among basic principles of holistic education the studies (in particular, (Mahmoudi et al., 2012; Miller, 2004, 1991; Miller et al., 2005)) point out some pillars which seem to be essential in the context of the problems of Mathematics training, mentioned above. The first principles expects students' freedom and autonomy. So, within the holistic paradigm any trainee is considered to be really active participant of the learning process who is ready to interact with reality through his own cognitive activity with his own ups and downs.

Next pillar of the holistic approach is necessity to establish connections and relationships between the object of learning and existing knowledge. The more links trainees have, the stronger memories are formed in their minds and better understanding of the whole they obtain.

Similar to the establishing links is the principle of transdisciplinarity which focuses teaching and learning on ruining boundaries between subject fields themselves as well as between subject areas and reality.

Researchers also point out that holism helps both the connection facet and transdisciplinarity, because it seems to be fruitful to learn separate things which in fact are not separate. However, at the same time it is necessary to understand how they work together.

The analysis of the holistic education basis reveals a need to apply efficient learning tools enabled to provide holistic approach to nowadays teaching and learning.

One of such tool seems to be computer dynamic models (CDM). The learning of recent studies on their didactic facilities testifies that CDM have quite

powerful potential as for revealing transdisciplinary connections and facilitating their understanding by trainees. In particular, researchers point out that CDM are typically based on the mathematical model of a concept (process, phenomenon, etc.), and enable to visualize its essence at real time operation, learn dynamic changes, and investigate the concept or process via active cognition. In such a way CDM help to form and develop students' techniques of mental activity including transdisciplinary ones (Semenikhina and Drushliak, 2014; Alessi, 2000).

Characterizing advantages and facilities of CDM using in the context of holistic education, it is important to emphasize that they encourage students to learn objects independently and actively. In addition, they reveal and demonstrate in action the wholeness of the learnt concepts (phenomenon).

In this context, it is essential to focus on the valuable potential of contemporary mathematical computer environments which enable to create the models of different complexity, visualize changes of the model behavior and do proper research. Despite the great variety of the said software on the modern IT market, we would like to focus on modeling facilities of free GeoGebra software which provides a trainee with convenient tools to develop a CDM, and do effective simulations and investigations with it. In particular, GeoGebra allows to create geometrical objects and obtain easily their algebraic interpretation; get interactive and dynamic visualization of the objects of various essence; manipulate with the model parameters to monitor the changes etc (Pikalova, 2018; Kramarenko et al., 2020). In addition, online service GeoGebraTube grants the access to the variety of existing elaborations provided by the global GeoGebra community which unites the educators and students all over the world.

Nowadays, GeoGebra Institutes work in many countries and make together International GeoGebra Institute (IGI) as a global organization that nourishes and stimulates collaboration between practitioners and researchers, seeking to expand the community of independent GeoGebra users.

GeoGebra Institute, Kharkiv, Ukraine, which has been realizing its mission since 2010 within IGI, focuses on:

- 1) promoting the dissemination and productive use of software, scientific, educational, methodological developments of the international GeoGebra community in professional activities of mathematicians and other specialists;
- 2) encouraging students and teachers to conduct research in mathematics, physics, computer science and information technology;

- 3) implementation of the concept of STEM-education in educational practice;
- 4) involvement of students and teachers in cooperation with the international GeoGebra community via participation in the conferences and other events initiated by the IGI.

One of the interesting and significant inter-university projects of Kharkiv GeoGebra Institute was involving students of various specialties into modeling activity focused on various GeoGebra models elaboration and learning the modeled objects (processes, dependences etc.).

The purpose of the article is to represent students' modeling activity which resulted in the complex of GeoGebra models focused on holistic learning of Mathematics at higher school and university.

2 THEORETICAL FRAMEWORK

During the research, the set of theoretical, empirical, and modelling methods were applied.

Characterizing the arrangement of the said students' modeling activity within Kharkiv GeoGebra Institute, we can describe all necessary stages of the work.

At the first stage, the core task was formulated for the students as following: to develop the complex of GeoGebra models for the maintaining learning of Mathematics at higher school and university based on holistic approach.

In addition, there were formulated necessary requirements for the whole complex which determined its potential functions and enabled to realize exactly holistic paradigm according to its aim and principles (covered above).

In accordance with Requirement 1, the students had to develop different groups of models. The first group consists of the models which enable to facilitate mastering basic and complicated mathematical concepts (objects) by the potential trainees. The second group of the models must be focused on the realization of transdisciplinary connections between Mathematics and other subject domains. The third group has to provide real-life problems solving, based on the models investigation. Such models and simulations should emphasize the meta-role of Mathematics as well as demonstrate its practical value (rather than pure abstract science).

Requirement 2 determined all the models to be dynamic, to visualize immediately the results of the trainee's manipulation and encourage them to learn the modeled concept actively, via their own experience.

Requirement 3 expected the complex to be cloud-based, that is, to be available at www.geogebra.org for the global GeoGebra community. According to recent studies, cloud-based learning environment for teaching and learning STEM disciplines opens wide horizons for holistic education due to the realized support for various processes of learning and research activities; great level of learning resources flexibility; integration of variety of educational components based on innovative technologies. On the other hand, it seems to be powerful motivational factor for the students evolved into the complex elaboration as their work makes them participants of the global community.

Thus, at the first stage of the modeling activity, the students had to understand main features of holistic theory, to realize their core task and the common requirements to the complex, plan the work and allocate sub-tasks.

Next stage of the work was analytical one which created necessary theoretical background for development of all three groups of dynamic GeoGebra models.

At this stage of the complex elaboration the students made deep and comprehensive analysis of Mathematics to reveal its key concepts and their potential links with the notions of other subject domains. In order to meet the main pillars of holistic educational approach (covered earlier) it is necessary to reveal key objects of learning in the subject areas, establish connections between them, and build chains of proper transdisciplinary links.

Researchers distinguish different types of transdisciplinary connections. However, scientists (in particular, Bevz (Bevz, 2003), diSessa et al. (diSessa et al., 2004), McDonald and Czerniak (McDonald and Czerniak, 1994)) recommend to base the connections classification upon the set of three main grounds: information content of the subject domain, structure of learning activity, and organization of educational process.

As a result, considering the transdisciplinary connections from the standpoints of holistic education, the students had to reveal key concepts of subjects, detect their place in the current curriculum, consider peculiarities of their mastering and proper cognitive activity.

These procedures were done through the learning main content threads of the said curriculum subjects (Ministerstvo osvity i nauky Ukrainy, 2017a,b) and didactic analysis of each subject domain (covered in (Gryzun, 2018, 2016)). Main content threads of Mathematics, Science subjects (Physics, Chemistry, Biology) and Computer Science enabled us to reveal some transdisciplinary chains. We would like to point

out a paramount role of penetrating content threads in revealing transdisciplinary concepts and links between them. According to the Concept of the New Ukrainian School, there are four penetrating content threads – “Ecology security and sustainable development”, “Civil responsibility”, “Health and security”, “Financial literacy” – which are seen as a mean of key competences integration of all curriculum subjects. The penetrating threads are considered to be socially important meta-topics that focus teaching and learning on the trainees’ holistic understanding of the world. They are recommended to be regarded during the learning environment creation at all the levels of education (Elkin et al., 2017).

Finally, at the analytical stage of the described modeling activity, the students obtained the set of connection chains between the Mathematics and other subject domains. In particular, there were revealed the links:

- Mathematics – Computer Science;
- Mathematics – Physics;
- Physics – Mathematics – Biology;
- Mathematics – Economics;
- Mathematics – Building (design) and others.

Subsequent detailed analysis of the qualification standards, textbooks, and subject areas resulted in establishing of transdisciplinary links between the learning elements (LE), representing concepts and phenomena which are co-explored by several subject domains. In particular, the effective semantic analysis was held with the help of specialized software, such as: TextAnalyst 2.0, Text Miner 12.1 (its Text Parsing Node), Trope 8.4.

Such a “smart” analysis of the subject areas enabled to distinguish the weightiest LEs of the specific subject area along with their conceptual links. Basing on the depicted analysis, for the revealed weightiest LEs of Mathematics it was built a graph, representing their transdisciplinary links with exact learning elements (LE1...LEn) of other subject domains (SD), according to the chains of connections mentioned earlier.

The general scheme of the graph representing their transdisciplinary links with exact learning elements (LE1...LEn) of subject domains (SD) as well as the example of the graph for selected LEs, representing the transdisciplinary links for the chain: Physics-Mathematics-Biology (Used below for the transdisciplinary Model “Lens”), are given on the figures 1 and 2.

3 RESULTS AND DISCUSSION

The results of theoretical framework were used by the students at the design stage of their modelling activity on the development of the complex of GeoGebra models, focused on holistic learning of Mathematics at higher school and university.

The process of the models elaboration provided by the students (with accordance to the requirements formulated at the preparation stage) embraces some phases. At the first phase mathematical model of the future computer model is built. At this point it is done:

- 1) revealing and learning of the transdisciplinary essence of the proper concept (See theoretical framework);
- 2) defining of the mathematical dependencies which can illustrate and investigate the concept;
- 3) determination of the fixed model parameters and changeable ones along with the range and step of their changes;
- 4) picking up proper graphic elements which are able to illustrate dynamic changes;
- 5) revealing of transdisciplinary tasks and real-life problems which might be solved by the model;
- 6) elaboration of didactic support as a scheme of work upon the transdisciplinary tasks and real-life problems directed on the forming holistic image of the said concept (phenomenon).

At the second phase the mathematical model is built in the environment of GeoGebra. In particular, the set of standard GeoGebra tools are used (Points, Lines, Special Lines, Polygon, Circle and Arc, Measurement, Transformations) as well as the CAS components (Calculations and Analysis Tools). For realization of dynamic transformations, the Action Object Tools and Movement Tools are used (Semenikhina and Drushliak, 2014; Pikalova, 2018).

In order to make the use of the complex more flexible and available to a wide community of students and teachers, it was organized it in the form of GeoGebra Book. GeoGebra Book is a cloud service which enables to gather GeoGebra resources, to enhance them didactically, and to share them easily. Due to this fact, the complex of models is oriented to be a component of a cloud-based learning environment available to the global GeoGebra community.

The third phase is devoted to the testing, debugging and improving of the model.

The models in the complex are grouped in the three sections according to the Requirement 1: the

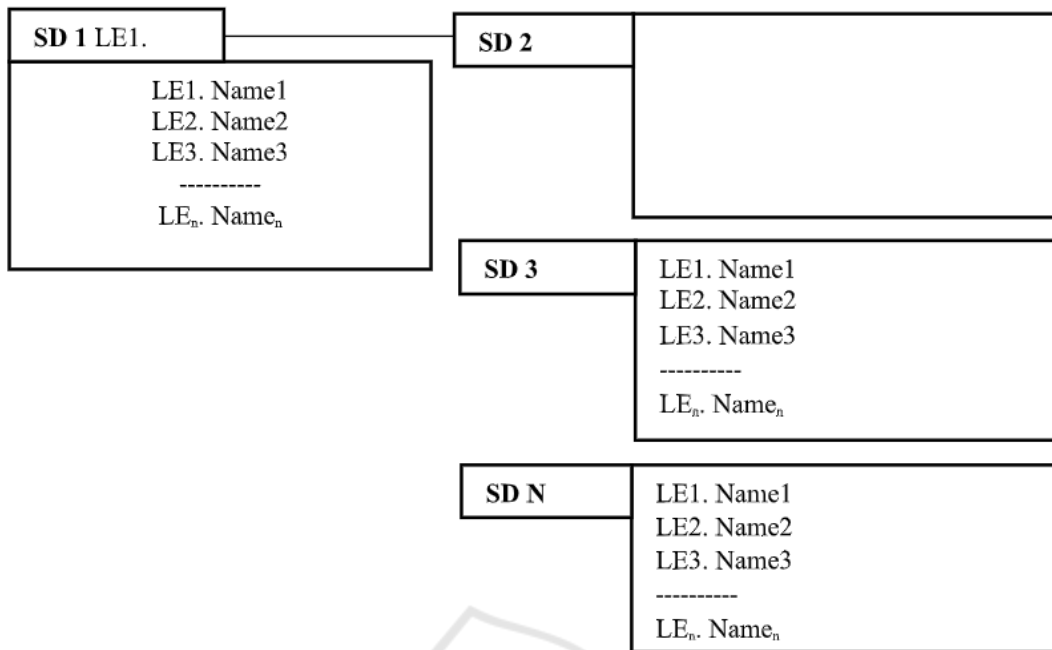

Figure 1: The common scheme of the graph, representing their transdisciplinary links with exact learning elements (LE1...LEn) of subject domains (SD).

first group consists of the models which enable to facilitate mastering basic and complicated mathematical concepts (objects) by the potential trainees; the second group is focused on the realization of transdisciplinary connections between Mathematics and other subject domains; the third group embraces models which provide real-life problems solving based on the models investigation.

Each of the models is presented in the complex according to the general scheme.

It includes (see examples below):

- model title;
- chain of the transdisciplinary links which are illustrated by the model;
- model description which explains concept (phenomenon) that is a prototype of the model;
- dynamic model itself with a proper functionality;
- procedure of cognitive activity on the realizing the essence of the concept (phenomenon);
- didactic support as a set of transdisciplinary tasks and real-life problems for forming holistic image of the said concept (phenomenon), and a scheme of work upon them;
- graph of the revealed transdisciplinary links for the visualization and remembering this holistic representation.

As it was mentioned above, holistic education expects trainees' personal cognitive activity. In order to facilitate it, it was elaborated procedure of cognitive activity which includes some tips on changing the parameters of the dynamic model, monitoring the results, investigating, making conclusions etc. Such a procedure is aimed to streamline understanding the essence of the concept (phenomenon).

The didactic support for each model is developed to involve potential trainees into the solving special problems and real-life tasks which encourage them to obtain holistic understanding of the basic concepts via special cognitive activity based on work with dynamic models. All of the tasks focus the trainees on the revealing and realizing transdisciplinary links.

Some of the models with their description and functionality are included into more than one subject section. However, didactic support as a set of transdisciplinary tasks for each model is specific in each section and focuses on different transdisciplinary connections.

Below we demonstrate fragmentary some of the models from various groups of the complex created by the students within the modeling activity (according to general scheme of model presentation depicted above) and offer recommendations as for their using to provide holistic learning of Mathematics at high school and university.

As it was said above, the dynamic models of the

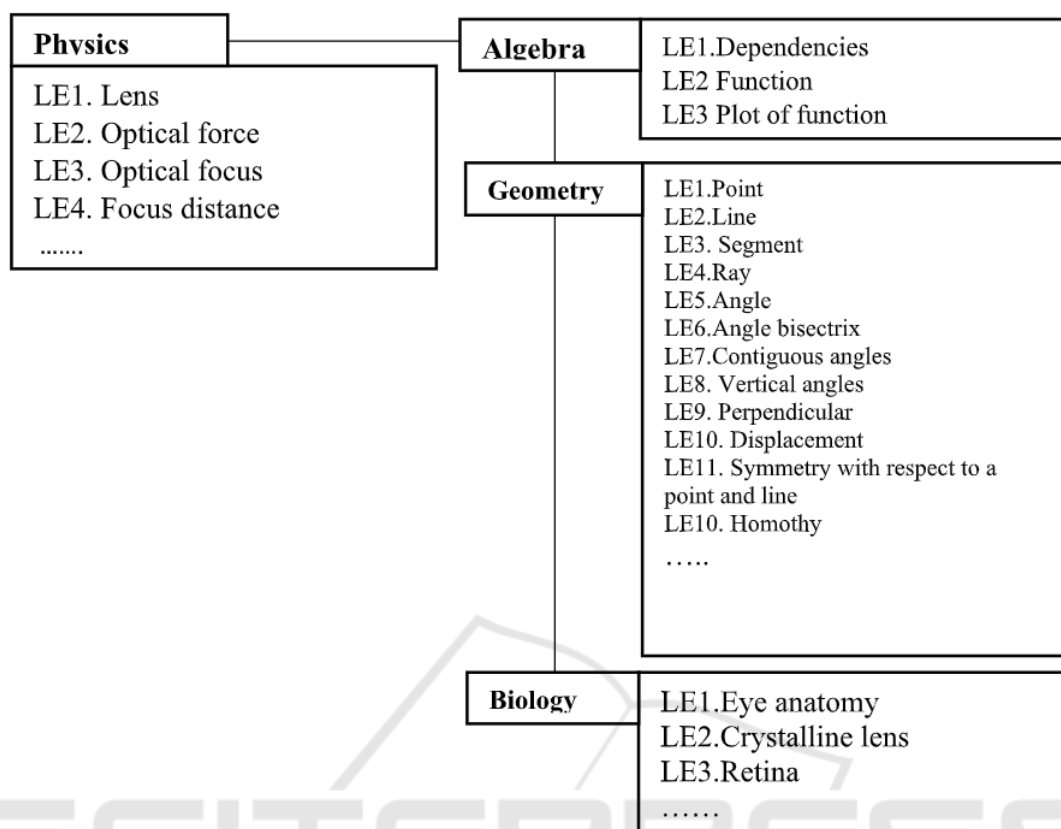

Figure 2: The example of the graph for selected LEs, representing the transdisciplinary links for the chain: Physics-Mathematics-Biology (Used below for the transdisciplinary Model “Lens”).

first group enable to facilitate mastering basic and complicated mathematical concepts (objects) by the potential trainees. The models are accompanied by special didactic support focusing them on investigation and holistic learning of the modeled concept. A lot of the models expect the model transformation by a trainee with the aim of its extension on different class of problems.

Among the models of this group it is worth mentioning the models *Elementary functions investigation* (figure 3), *Triangular properties learning*, *Graphical inequalities solution*, *Calculation of the area limited by the curve* (figure 4), *Remarkable curves investigation*, *Investigation of the approximation curve* and others.

Example 1. Model “Remarkable curves investigation. Epicycloids”

Chain of the transdisciplinary links: Geometry-Algebra-Mechanics.

Model description: According to definition, epicycloids is a plane curve made by tracing the path of the fixed point P on the circumference of a circle

(called epicycle) which rolls without slipping around another fixed circle. R is the radius of the fixed circle, r is the radius of the rolling circle. The model is built based on the kinematic definition of epicycloids and illustrates its different types. Unlike cycloid, epicycloids are not transcendental.

Procedure of cognitive activity with the model (selected tasks of the elaborated didactic support by the students):

1. Manipulate the model parameters to figure out how the number of the curve lobes depends on the ratio n of R and r. Answer the questions:
 - What types of epicycloids is obtained at n=1, n=2, n=3?
 - What happens, when n is integer and when n is rational? Make conclusions.
2. Monitor the model work, and calculate position of the point P via radiuses (R, r), the radian from the tangential point to the moving point and the radian from the starting point to the tangential point.
3. Transform the original model of epicycloids into the model of hypocycloid, answering the ques-

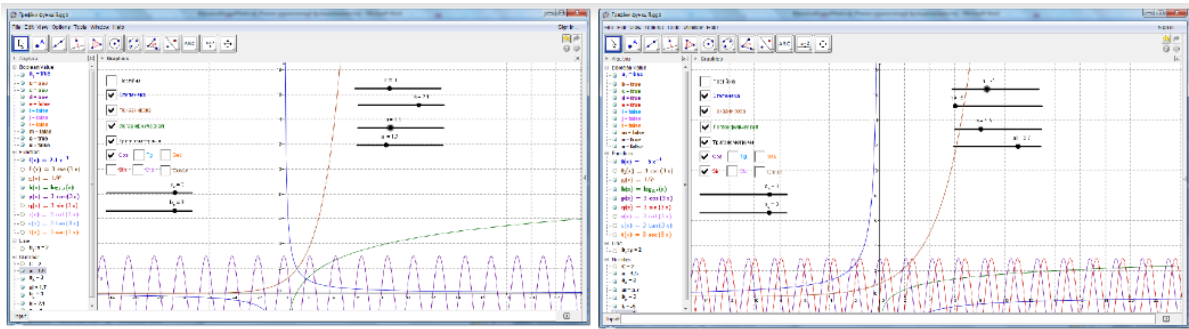

Figure 3: Episodes of cognitive activity on the model *Elementary functions investigation*.

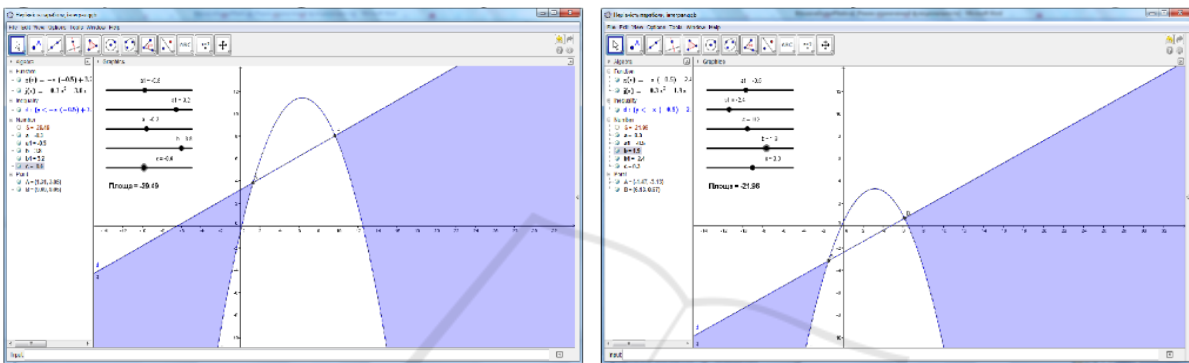

Figure 4: Episodes of manipulation with the model *Calculation of the area limited by the curve*.

tions and doing proper steps:

- How to calculate R now, when the small circle “rolls” along inside part the bigger circle?
 - How to calculate the speed of the point P which remain the trace? Why?
 - How must animated points P and the center of smaller circle move now? How are their movement directions related?
4. Use obtained model of hypocycloid, monitor its work and convince that its number of cusps is also controlled by the ratio n. Investigate the curve behavior, answering the questions:
- How many cusps does the curve have, if n is integer n?
 - How is hypocycloid transformed at n=2?
 - What value of n stops the work of the model? Why? How does the curve look like?
 - Investigate the curve behavior at $1 < n < 2$ and $n > 2$. Make conclusions.

Selected episodes of the students’ cognitive activity with the dynamic model “Remarkable curves investigation. Epicycloids” are given on the figure 5.

The models of the second group are concentrated on the realization of transdisciplinary connections between Mathematics and other subject domains. In

particular, it contains the models *Clock* (connections: algebra, geometry, trigonometry, physics, sociology, history, philosophy); *Mathematical pendulum* (connections: mathematics, physics) (figure 6); *Number systems* (connections: algebra, computer science, discrete mathematics, history); *Binary tree* (connections: discrete mathematics, computer science) (figure 7) and many others.

Work upon the transdisciplinary models of the second group is selectively shown in the Example 2 below.

Example 2. Model “Lens”

Chain of the transdisciplinary links: Physics-Mathematics-Biology.

Model description: The model illustrates principle of operation of a lens as a simplest optical device that focuses or disperses a light beam. A lens consists of a single piece of transparent material (e.g. glass or plastic). A lens can focus light to form an image which differs it from prism (See Model “Optical dispersion”). A lens has its optical axis, two focuses, main optical center and plane (you can find their definitions in your textbook). Lenses are classified by the curvature of the two optical surfaces. The model demonstrates the operation of exactly biconvex lens.

Procedure of cognitive activity with the model (se-

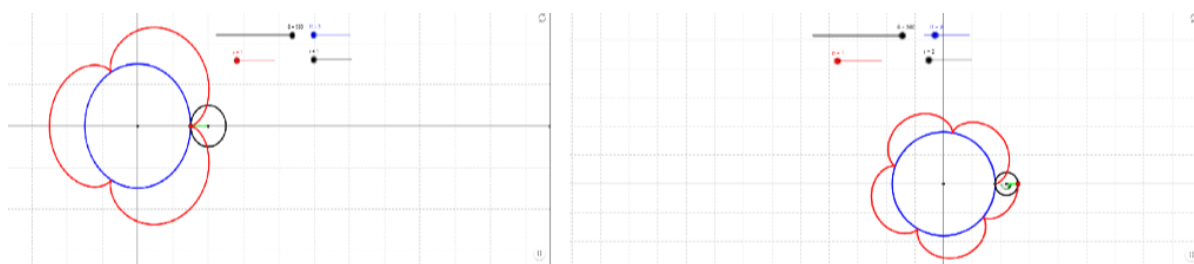

Figure 5: Episodes of the students' cognitive activity with the dynamic model "Remarkable curves investigation. Epicycloids".

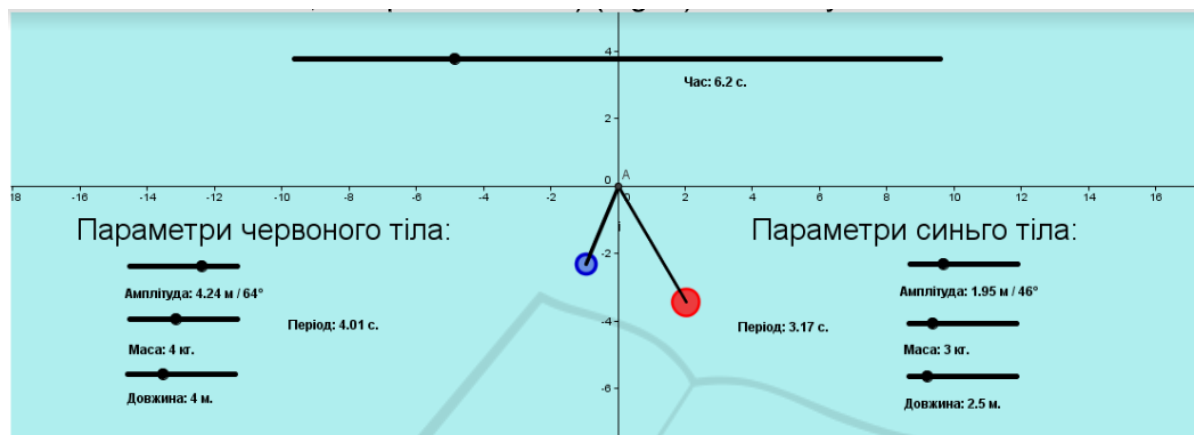

Figure 6: Episodes of the students' cognitive activity with the transdisciplinary model *Mathematical pendulum*.

lected tasks):

1. Operate the model. Change curvature with the slider. Monitor the focuses positions and image positions. Find and formulate dependences.
2. Fix the lens curvature and change the object position relative to the focus. What is happening with the image of the object?
3. Fix the object at the distances: $d=2F$, $d>2F$, $d<2F$. Analyze changes and make conclusions.
4. Analyze changes of the image's size and position when the object is between $2F$ and F , between F and lens center.

Fragment of didactic support as a set of transdisciplinary tasks and real-life problems for forming holistic understanding of the optical device from the standpoint of Mathematics, Physics, and Biology):

1. Manipulate the model parameters. What is mathematical dependence between object distance to the lens and focus distance? How is it called? Write the formula of the dependence.
2. What geometrical figures describe the object, its image, light beams and the phenomena of light penetration through the lens?
3. What geometrical facts and properties are revealed by the device operation?

4. Which angles are equal at any values of the model parameters? Why? Which rays are parallel? Why?
5. Working with the model, detect the parameters of the model which provide the highest optical power of the lens.
6. Manipulating the model and using the scheme of the optical system of a human eye (figure 8), answer the questions: (1) what are the components of the eye optical system? (2) what is the difference between real and virtual image? (3) what are the basics of a human eye functioning from the standpoint of physics? (4) can you explain eyesight disorders (short sight, long sight, etc.) via physical concepts and phenomena? (5) compare the principles of human eye operation and work of a digital camera.

Episodes of transdisciplinary tasks doing and the model operating are shown on the figure 9.

Graph of the revealed transdisciplinary links for the visualization and remembering this holistic representation presented on figure 2 above.

The third group of the created models embraces ones that provide real-life problems solving based on the so called STEM investigation. As it is expected by the requirements, the models of the third group enable simulations which help realize the meta-role of

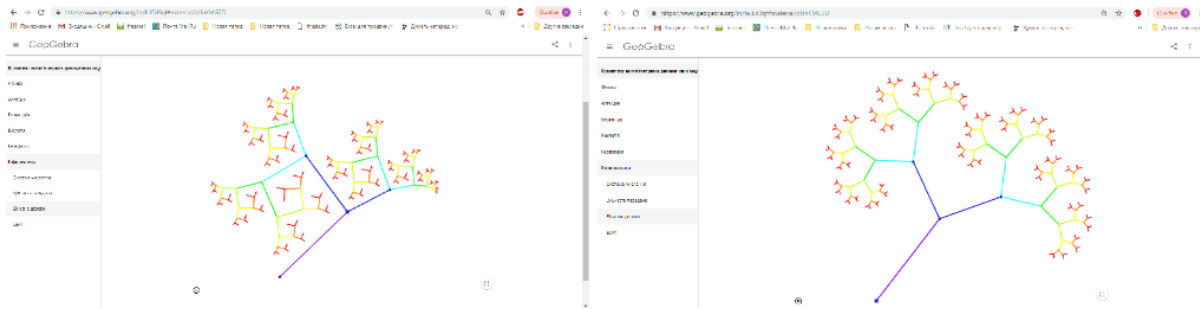

Figure 7: Episodes of the students' cognitive activity with the transdisciplinary model *Binary tree*.

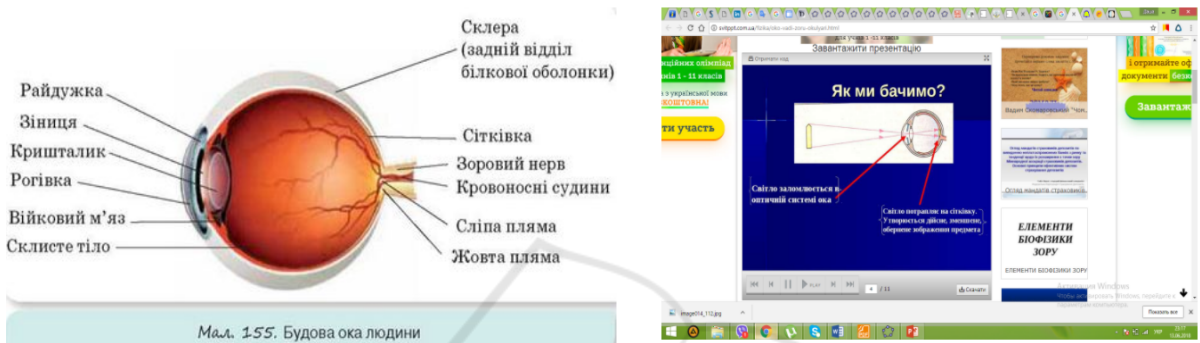

Figure 8: Scheme of the optical system of a human eye.

Mathematics as well as demonstrate its applied value for practical daily needs. It includes the models such as *Investigation of shooting path*; *Lift work*; *Geometrical transformations in real-life measurements*; *Remarkable triangular points*; *Bridge approximations* and many others.

Selected fragments of the real-life tasks solving within the dynamic models *Investigation of shooting path* and *Geometrical transformations in real-life measurements* are given on the figure 10.

Below we are giving the example of STEM investigation which it is recommended to build, maintaining the model *Fermat-Torricelli points investigations*.

Example 3. Real-life problems solving on the model *Fermat-Torricelli points investigations*

Investigation 1. Construct the second Fermat-Torricelli point by constructing right triangles on the sides inward. Investigate the properties of the Fermat-Torricelli point: the sum of the distances from the point to the vertices of the triangle is minimal, and all the vertices are visible from it at an angle of 120° .

Investigation 2. Using the obtained dynamic model, investigate the position of the Fermat-Torricelli point (with to the triangle), when the triangle has one angle greater than 120° . Determine whether it will have its properties in this situation.

Determine how the point will behave when there is an angle of 120° .

Investigation 3. Elaborate the model and try to figure out how to use the properties of the point to solve current problems in your city.

1. Imagine that you need to place the emergency medical center so that it was at a minimum distance from the three points of the city A, B, C. Using a digital map of the city as a working geometric field GeoGebra.
2. Match the points of the city to the vertices of the triangle and determine if there is a Fermat-Torricelli point for this triangle, find this point for it.
3. Determine which geographical point on the map corresponds to the found Fermat-Torricelli point. Investigate whether it is possible to locate an emergency center at this point in terms of social, economic and geographical conditions.
4. If this is not possible, manipulate the model parameters, change the position of the points A, B, C and find out their geometric location so that the built triangle and its Fermat-Torricelli point meet the current social needs of the city.

Investigation 4. Formulate a mathematical problem about the use of the properties of the Fermat-Torricelli point, which can arise when building roads

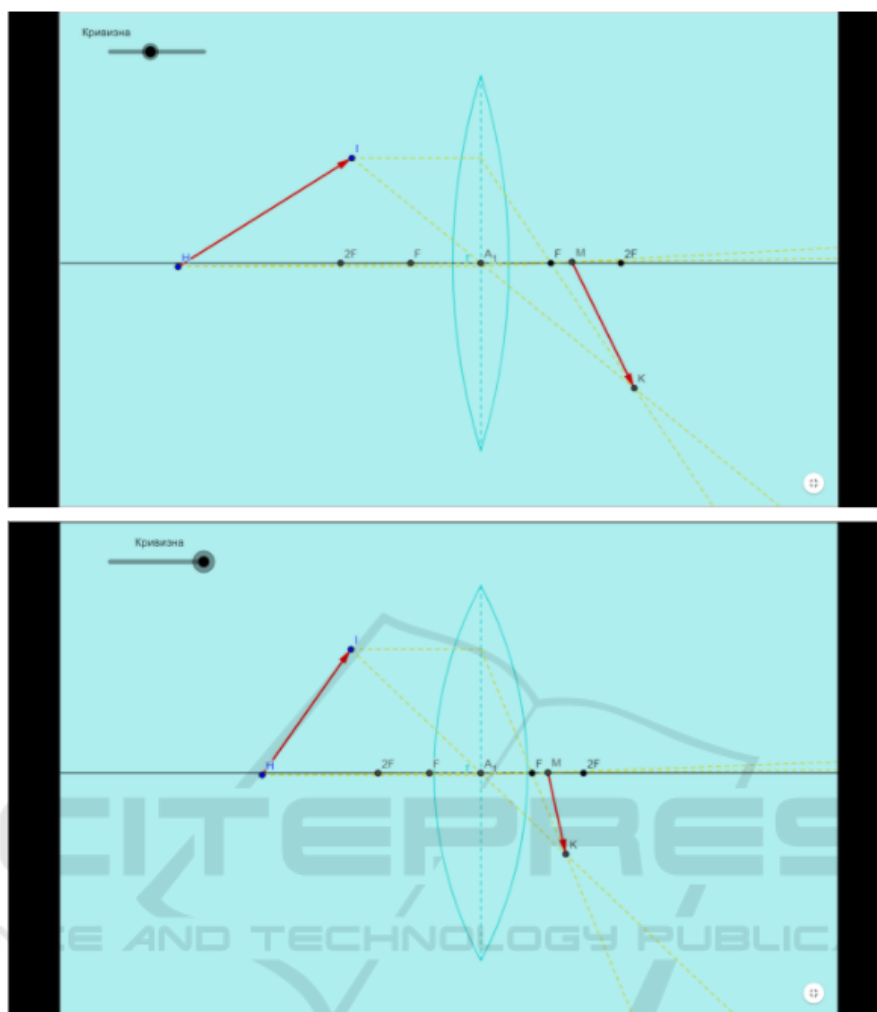

Figure 9: Episodes of transdisciplinary tasks solving, operating the model “Lens”.

between settlements in your region in order to save resources. Use the dynamic model to solve and investigate this problem.

Summarizing the presentation of the complex of GeoGebra dynamic models created by the students (pre-service specialists of different specialities) within the realization of holistic approach to their mathematical training, we would emphasize that besides models, the students developed special didactic support as a set of transdisciplinary tasks and real-life problems for forming holistic image of the said concept (phenomenon).

The prepared didactic support includes the transdisciplinary tasks of various types. In particular, there are tasks on establishing connections between mathematical concepts and notions of other subject areas. The aim of these tasks is to specify and generalize mentioned connections; to form the system of the no-

tions of different level of generalization and subordination; to illustrate casual relations of phenomena. This type of the problems are directed on the forming of the set of potential trainees’ skills of integrative properties: to understand meta-role of Mathematics for other domains of knowledge; to explain processes and phenomena of one domain with the help of concepts of other branch; to make outlook conclusions based on common concepts, and others.

Besides, the developed didactic support can offer transdisciplinary tasks for potential trainees on the determination of community of the facts from different subject domains. They allow to specify learning material, to form new mathematical concepts and explain them from the standpoints of other branches of science, to use some mathematical facts to illustrate other ones. Such tasks are aimed at the forming students’ skill of facts’ analysis, generalization and

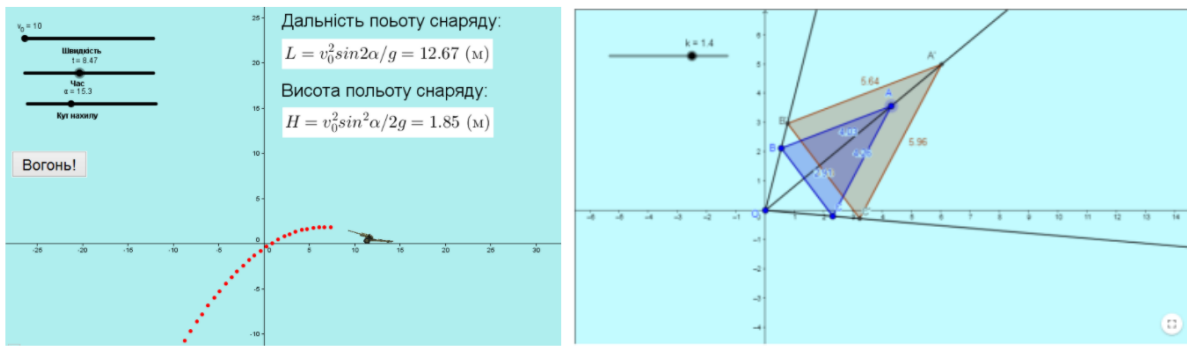

Figure 10: Selected fragments of the real-life tasks solving within the dynamic models Investigation of shooting path and Geometrical transformations in real-life measurements.

explanation from the standpoint of general scientific ideas; skill to integrate generalized facts into the existing knowledge system; skill to apply generalized knowledge into practice.

In addition, into the didactic support there are included the tasks on the establishing connections between theoretical knowledge and methods, and their practical use. Mostly they are real-life problems which focus on the ruining boundaries between Mathematics, other subject domains and reality. They might help to form the trainees' ability to see scientific subtext in pure practical tasks, to attract generalized knowledge from related areas, and to apply them to resolving the problem.

Thus, the cloud-based complex of GeoGebra models (created by the pre-service specialists of different specialities) as for their functionality provides main principles of the holistic education, such as connections establishing, personal cognitive activity, focus on the ruining boundaries between subject fields and reality.

It seems to be relevant to predict positive influence of the complex application on the forming of potential trainees' holistic system of mathematical knowledge.

In addition, we would like to point out that the complex is a result of modeling activity of the students within the realization of holistic approach to their mathematical training. In this context, our observations and monitoring all the stages of the students' simulation work in the process of the complex development, allow to predict not only raising the level of their mathematical knowledge. Our monitoring programs and regular surveys also testify definite impact on the level of the students' investigative (enquiry) skills. In particular, there was detected positive dynamic of cognitive, motivational and behavioral components of the said skills. Generalization and statistical analysis of the obtained empirical results make prospects of our research.

4 CONCLUSIONS

In accordance with its purpose, the article represents students' modeling activity (held within inter-university projects of Kharkiv GeoGebra Institute) which resulted in the complex of GeoGebra models focused on holistic learning of Mathematics at higher school and university.

Proper theoretical background for the complex design is elaborated and the stages of the students' modeling activity are covered. The models in the developed complex are grouped in the three sections. The first group consists of the models which enable to facilitate mastering basic essential mathematical concepts (objects) by the potential trainees. The second group is focused on the realization of transdisciplinary connections between Mathematics and other subject domains. The third group embraces models which provide real-life problems solving based on the models investigation. All the groups are represented in the article along with specific examples of the models.

In order to facilitate potential trainees' personal cognitive activity that is expected by holistic education, it was elaborated procedure of cognitive activity which includes some tips on changing the parameters of the dynamic model, monitoring the results, investigating, making conclusions etc. Such a procedure is aimed to streamline understanding the essence of the concept (phenomenon). The didactic support for each model was developed by the students to involve potential trainees into the solving special problems and real-life tasks which encourage them to obtain holistic understanding of the basic concepts via special cognitive activity based on work with dynamic models. The said didactic support is characterized in the paper.

The prospects of further research are outlined.

REFERENCES

- Alessi, S. (2000). Designing educational support in system-dynamics-based interactive learning environments. *Simulation & Gaming*, 31(2):178–196.
- Bezv, V. (2003). Mizhpredmetni zviazky yak neobkhidnyi element predmetnoi systemy navchannia (Transdisciplinary connections as a necessary element of the subject system of learning). *Matematyka v shkoli*, 6:6–11.
- Bilousova, L., Gryzun, L., Zhytienova, N., and Pikalova, V. (2019). Search algorithms learning based on cognitive visualization. *CEUR Workshop Proceedings*, 2387:472–478.
- Bobyliiev, D. Y. and Vihrova, E. V. (2021). Problems and prospects of distance learning in teaching fundamental subjects to future mathematics teachers. *Journal of Physics: Conference Series*, 1840(1):012002.
- diSessa, A. A., Gillespie, N. M., and Esterly, J. B. (2004). Coherence versus fragmentation in the development of the concept of force. *Cognitive Science*, 28(6):843–900. https://onlinelibrary.wiley.com/doi/abs/10.1207/s15516709cog2806_1.
- Elkin, O., Hrynevych, L., kalashnikova, S., Khobzey, P., Kobernyk, I., Kovtunets, V., Makarenko, O., Malakhova, O., Nanayeva, T., Shiyani, R., and Usatenko, H. (2017). *The New Ukrainian School: conceptual principles of secondary school reform*. MESU, Kyiv. <https://mon.gov.ua/storage/app/media/zagalna%20serednya/Book-ENG.pdf>.
- Gryzun, L. (2016). Integrative technology of academic subjects structuring and its applications to practical didactic issues. *Aktualni pytannia humanitarnykh nauk*, 16:309–315. http://www.aphn-journal.in.ua/archive/16_2016/39.pdf.
- Gryzun, L. (2018). Integrative approach to the curriculum and content design for the pre-service teachers' training. *PEOPLE: International Journal of Social Sciences*, 4(2):1446–1462. <https://grdspublishing.org/index.php/people/article/view/1572>.
- Kramarenko, T., Pylypenko, O., and Muzyka, I. (2020). Application of GeoGebra in Stereometry teaching. *CEUR Workshop Proceedings*, 2643:705–718.
- Mahmoudi, S., Jafari, E., Nasrabadi, H., and Liaghatdar, M. (2012). Holistic education: An approach for 21 century. *International Education Studies*, 5(3):178–186.
- McDonald, J. and Czerniak, C. (1994). Developing interdisciplinary units: Strategies and examples. *School Science and Mathematics*, 94(1):5–10. <https://onlinelibrary.wiley.com/doi/abs/10.1111/j.1949-8594.1994.tb12281.x>.
- Miller, J. (2004). Educational alternatives: A map of the territory. *Paths of Learning*, 20:20–27. http://www.holisticedinitiative.org/wp-content/uploads/documents/ron_millermmap_of_educational_alternatives.pdf.
- Miller, J. P., Karsten, S., Denton, D., Orr, D., and Kates, I. C., editors (2005). *Holistic Learning and Spirituality in Education: Breaking New Ground*. State University of New York Press, Albany.
- Miller, R., editor (1991). *New Directions in Education: Selections from Holistic Education Review*. Holistic Education Press, Brandon.
- Ministerstvo osvity i nauky Ukrainy (2017a). Bi-olohiia 6–9 klasy. navchalna prohrama dlia zahalnoosvitnikh navchalnykh zakladiv (biology grades 6–9. curriculum for general educational institutions). <https://mon.gov.ua/storage/app/media/zagalna%20serednya/programy-5-9-klas/onovlennya-12-2017/15.biologiia-6-9.docx>.
- Ministerstvo osvity i nauky Ukrainy (2017b). Navchalni prohramy dlia 5-9 klasiv (curriculum for 5-9 grades). <https://mon.gov.ua/ua/osvita/zagalna-serednya-osvita/navchalniprogrami/navchalni-programi-5-9-klas>.
- Pikalova, V. (2018). *Tutorial on mastering the dynamic mathematics package GeoGebra as a tool for implementing STEAM-education: a textbook*. KhNPU imeni H.S. Skovorody, Kharkiv.
- Semenikhina, O. V. and Drushliak, M. H. (2014). GeoGebra 5.0 tools and their use in solving solid geometry problems. *Information Technologies and Learning Tools*, 44(6):124–133. <https://journal.iitta.gov.ua/index.php/itlt/article/view/1138>.
- Singh, K. (1996). Education for the global society. In *Learning: The Treasure Within. Report to UNESCO of the International Commission on Education for the Twenty-First Century*. UNESCO Publishing. <https://www.gcedclearinghouse.org/sites/default/files/resources/%5BENG%5D%20Learning.0.pdf>.
- Vlasenko, K., Chumak, O., Sitak, I., Lovianova, I., and Kondratyeva, O. (2019). Training of mathematical disciplines teachers for higher educational institutions as a contemporary problem. *Universal Journal of Educational Research*, 7(9):1892–1900.