

BIOSIGNALS WITH A FLOOR SENSOR

Near Field Imaging Floor Sensor Measures Impedance Changes in the Torso

Henry Rimminen and Raimo Sepponen

Department of Electronics, Helsinki University of Technology, Otakaari 7B, Espoo, Finland

Keywords: Remote sensing, Non-contact measurement, Cardiac monitoring.

Abstract: We analyse biosignals recorded with a near field imaging floor sensor, using a test group of five people. This human tracking system is capable of non-contact biosignal recording. A time domain integration method is used to extract periodic cardiac waveforms from the raw signals, while an ECG signal is used as a trigger for windowing. The most favourable posture for cardiac monitoring is when the test subjects are lying prone on the sensor floor. A clear correlation between the test subjects can be found when waveforms in the lying prone or supine postures are compared. The respiration monitoring capability is also discussed.

1 INTRODUCTION

In this study, we analyse the recorded biosignals of a near field imaging floor sensor (Rimminen, 2008), using a test group of five people. The main purpose of this floor sensor is to track people walking on top of it, but the proposed applications of the floor sensor, such as care for the elderly and seclusion monitoring, would most probably benefit from a vital signs monitoring capability.

Recently, some promising results have been presented regarding the remote sensing of the human body. Using electric potential probes with input impedances up to $10^{15} \Omega$, a clear cardiac signal has been recorded from a distance of 3 millimetres (Prance et al., 2000) and later from a distance of one metre (Harland, 2001). Low impedance charge amplifiers have also proved their strength in off-body sensing. This technique has produced good results from a recording distance of up to 10 millimetres (Smith, 2004). These methods measure biopotentials produced by the human body, and no electrical stimulus is generated by the measurement system.

Some promising experiments have also been made with electret films, which produce a charge under pressure. These films produce clear cardiac and respiratory signals when applied to the chest and to the chair on which the subject is sitting (Alametsä, 2004). This method measures solely the fine movements of the body.

Unlike the works discussed above, our method uses a 90-kHz electrical stimulus to measure impedance changes in the torso, with no galvanic contact with the body. This kind of measurement is often referred as Electric field tomography (Korjenskyy, 2004), and has some applications using planar electrode arrays (Tuykin, 2007) similar to us. Instead of a spatial analysis, we sample the signal from one electrode, and analyse the results in the time domain. As far as we know, there is no implementation of a biosignal monitor integrated in a non-pressure-sensitive floor sensor.

The goal of this study is to analyse cardiac activity in the biosignals recorded with the near field imaging floor sensor. We also aim to find out which the most favourable postures are for this kind of recording. A secondary goal is to observe respiration in the recorded signals.

2 MATERIALS AND METHODS

2.1 Measurement System Overview

The positioning system under study measures impedance changes between conductive elements in a thick film sensor matrix (Rimminen, 2008). The rectangular sensor elements have a pitch of approximately 50 cm x 25 cm. One measurement unit can cover up to 255 sensor elements and 32 m^2

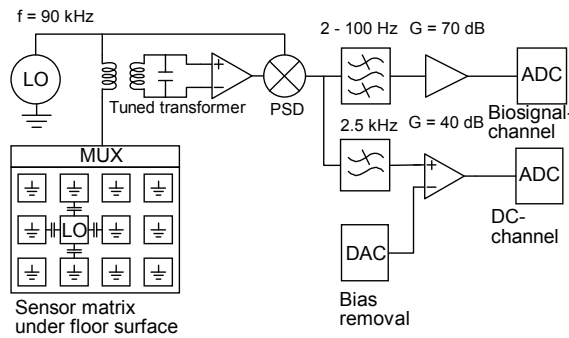

Figure 1: Block diagram of the measurement system. The local oscillator (LO) signal is fed to one sensor element at a time using an array of multiplexers.

of floor area. This means that small and medium size rooms can be covered entirely. These sensor films are installed under common dielectric floor coverings with thicknesses of up to 10 mm. The plastic floor covering in our test room is 3 millimetres thick. This justifies the use of the term “non-contact measurement”.

The amplitude of the recorded biosignal is assumed to be proportional to impedance changes in the body. Because of this assumption, we refer to the recorded samples as ΔZ signals.

The ΔZ recording is performed by feeding alternating current to a single sensor element and grounding the others (see Figure 1). The amplitude of the current is measured using a tuned transformer and phase sensitive detector (PSD). These structures perform well in rejecting common mode EMI. After this, the signal is fed through a band-pass filter and amplified by 70 decibels. Then we use a 10-bit a/d converter integrated in a microcontroller. The band-pass filter has a 50-Hz twin “T” notch to reject interference from the mains (National Semiconductor, 1969) (see Figure 2). The DC channel in Figure 1 is used for human tracking and is not discussed in this study.

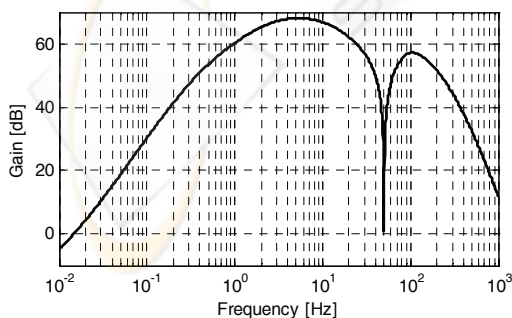

Figure 2: The simulated frequency response of the Biosignal channel.

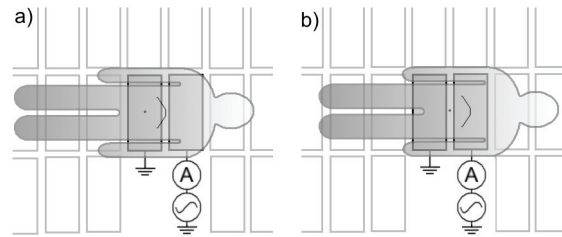

Figure 3: a) Sternal height recording b) Abdominal height recording. The grey rectangles represent the floor sensor elements.

2.2 Test Arrangement

We recorded 20 second samples of five different test subjects in four different lying postures. The postures were the following: prone, supine, left lateral, and right lateral. Two recordings were taken in each posture: from sternal height and from abdominal height (see Figure 3). We selected a fixed sensor element for the recording, which was marked on the floor covering. The total number of 20-second samples was 40. The test subjects were breathing normally during the recordings.

An ECG signal between electrode locations V2 and V4 was recorded simultaneously during every floor sensor recording. The ECG signal was acquired using wet electrodes and an instrumentation amplifier with an adjustable band-pass filter (PRE AMP Model 5113, Princeton Applied Research, Tennessee, USA).

The test group consisted of five M.Sc. students; three males and two females. The average weight was 74 kilograms, and the average age was 23 years. The use of elderly people as test subjects was not feasible because of the difficult postures on a hard floor surface.

2.3 Pulse Integration

To extract a periodic waveform that is characteristic for each test subject in each posture and recording point, we integrate the ΔZ signal in the time domain by windowing it. The windowing is done by using a simultaneously recorded ECG signal for timing. The rising edge of the QRS complex is used to trigger the start and stop of each window, which are then all summed together. This helps us to find the periodic cycles in the sometimes noisy ΔZ signal. From now on, we refer to them as the standard pulse waveforms.

The analysis of the standard pulse waveforms is performed by comparing the signal-to-noise ratios (SNR) of different test subjects and postures. We are

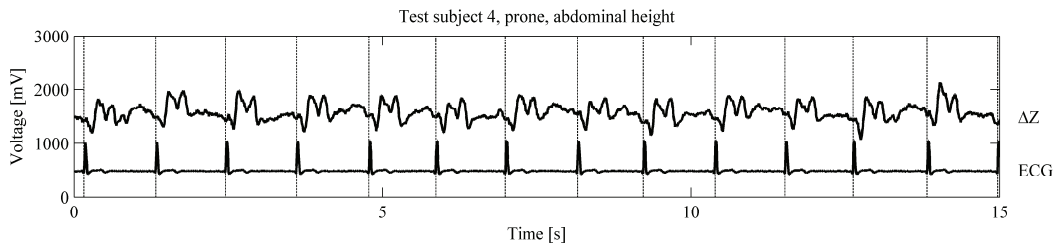

Figure 4: ΔZ signal and ECG signal recorded from test subject number 4 (male). The posture was prone and the recording was performed at abdominal height. Cardiac activity is clearly visible. SNR is 8.64.

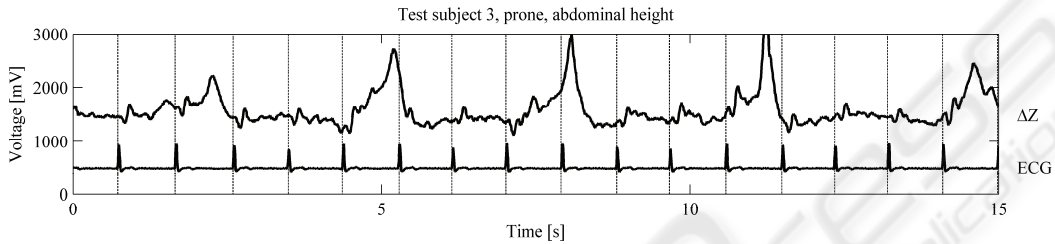

Figure 5: ΔZ signal and ECG signal recorded from test subject number 3 (male). The posture was prone and the recording was performed at abdominal height. Both cardiac activity and respiration are clearly visible. SNR is 3.77.

interested in finding out if some postures are more favourable than others, and if some people produce stronger cardiac signals than others. The SNR is calculated by taking the true rms voltage of a standard pulse waveform and dividing it by the rms voltage of the base noise. The base noise is measured by recording a 20-second sample while the floor is empty. Correlation coefficients are also calculated in order to find out if different people produce similar signals in the same postures.

3 RESULTS

3.1 Raw Signals

Some of the raw samples are presented in Figures 4, and 5. The first shows clear cardiac activity, and the latter shows clear respiratory activity. The simultaneously recorded ECG signals are plotted under the ΔZ signals. Dashed vertical lines represent the windowing separators triggered by the rising edges of the QRS complexes in the ECG signals.

3.2 Integrated Pulses

When the raw ΔZ signals are integrated in time using the pace provided by the ECG signal, we get the standard pulse waveforms presented in Figure 6. The dark grey traces represent individual test subjects, and the light grey fill colour represents the

variation within the whole test group. The black trace shows the average within the group.

It seems that the clearest peaks in the averaged pulses are present in the prone posture. Also the supine posture at abdominal measurement height produces clear peaks.

Table 1 shows the SNR values of the standard pulse waveforms in every posture and at every recording point. The higher the SNR, the stronger the cardiac signal. Respiration and other artefacts in the signal do not affect the SNR value because of the ECG-based windowing. The averaged SNR of each test subject is shown in the last row, and the average of each posture is shown in the right-hand column. The rms base noise voltage used in the SNR calculations was 14.03 mV.

The correlation coefficients of the postures and recording points are presented in Table 2. These values are averages of the correlation coefficients between the test subjects in a certain posture and at a certain recording point.

If the correlation is high, people produce similar signals in the same posture and at the same recording point. High correlation can also be seen as a narrow grey area in the corresponding part of Figure 6.

It seems that the correlation between the test subjects is over 50 percent in the prone posture. It is also noteworthy that the correlation reaches 33 percent in the supine posture at abdominal measurement height.

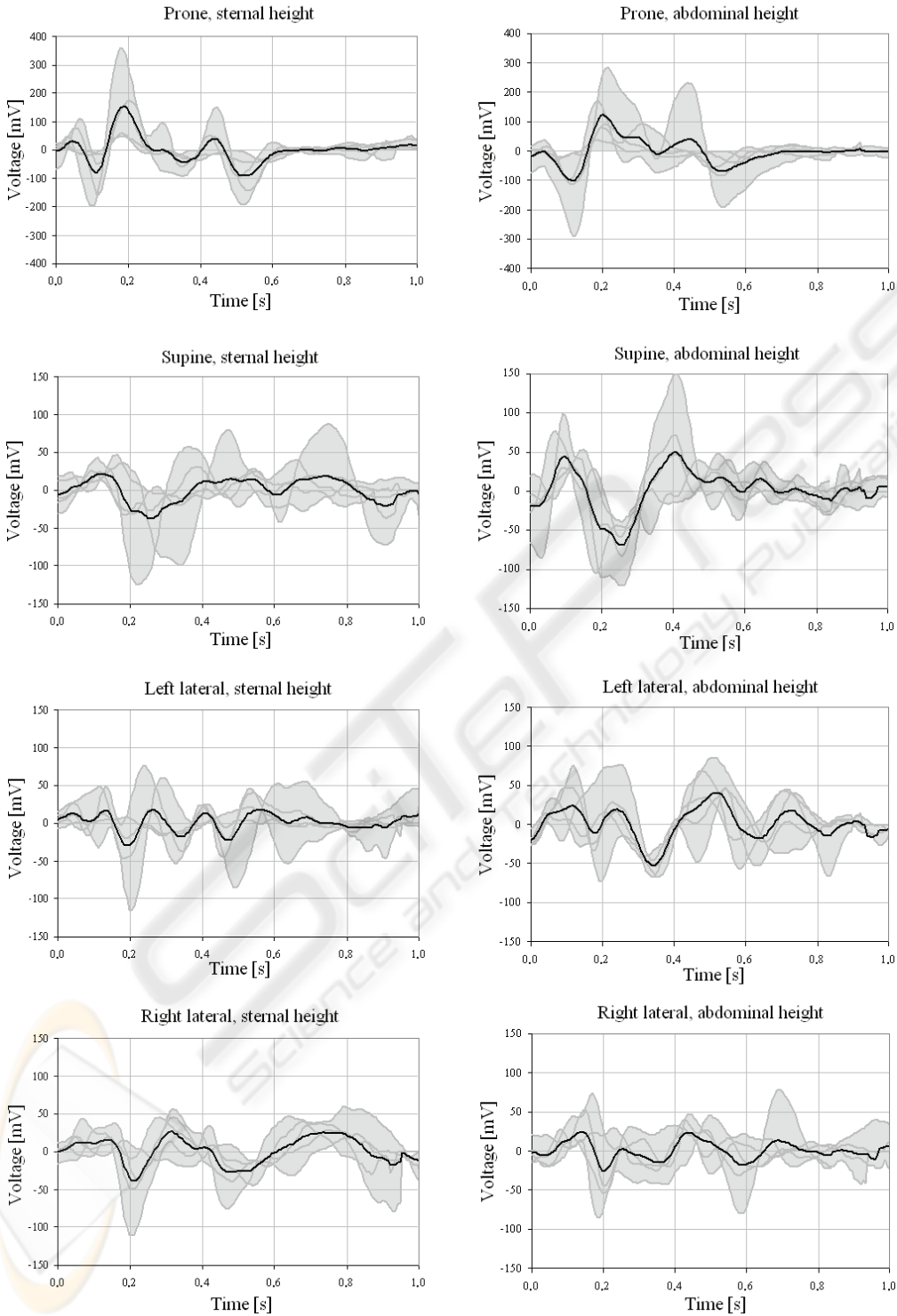

Figure 6: The standard ΔZ pulse waveforms of all test subjects in each posture and at each recording point. The black trace is an average of the test group. The grey fill colour represents the variation within the test group. Note that the y-scale in the prone postures is larger (from -400 mV to +400 mV) than in the other postures (from -150 mV to +150 mV).

Table 1: Signal-to-noise ratio in different circumstances.

SNR	Test subjects					Average
	1 ♀	2 ♀	3 ♂	4 ♂	5 ♂	
Prone, sternal ht.	1.79	1.34	7.92	4.75	3.80	3.92
Prone, abd. ht.	1.89	0.85	3.77	8.64	3.20	3.67
Supine, sternal ht.	3.77	1.18	0.96	2.52	1.27	1.94
Supine abd. ht.	1.68	1.27	2.71	4.11	2.22	2.40
Left lateral, sternal ht.	2.03	0.58	0.61	2.87	1.93	1.60
Left lateral, abd. ht.	2.30	1.39	1.71	2.66	2.60	2.13
Right lat., sternal ht.	1.38	0.95	2.17	2.92	2.30	1.95
Right lat., abd. ht.	1.35	1.24	1.27	2.01	2.46	1.76
Average	2.03	1.10	2.70	3.81	2.47	2.42

Table 2: Correlation between the test subjects.

Posture and recording point	Mean correlation
Prone, sternal ht.	0.555
Prone, abdominal ht.	0.500
Supine, sternal ht.	0.043
Supine, abdominal ht.	0.325
Left lateral, sternal ht.	0.093
Left lateral, abdominal ht.	0.265
Right lateral, sternal ht.	0.193
Right lateral, abdominal ht.	-0.033
Average	0.243

4 DISCUSSION

The floor sensor produces a cyclic cardiac signal, which has the same period as a simultaneous ECG recording. The cardiac signal presumably originates from changes in the blood concentration in the torso. The relatively good conductance of blood reduces the average tissue impedance seen with the sensor elements. The cardiac waveform recorded with the floor sensor resembles remotely the ΔZ signal in impedance cardiography (Patterson, 1989). However, this similarity is present only in the prone postures.

The results show that the cardiac signal is clear when test subjects are lying prone on the sensor elements. The sternal height recording point seems to be slightly better than the abdominal height recording point. The SNR values when they are lying prone are significantly higher than in other postures (see grey cells in Table 1). Postures other than lying prone produce weaker signal amplitudes;

however, they are still mostly above the base noise (SNR > 1). The two females in this test group had lower SNR values than the males.

The standard pulse waveforms show a clear correlation between all the test subjects in both of the prone recording points. This suggests that this recording method could be reproducible and that people produce similar waveforms in the prone posture. Also the supine posture at abdominal measurement height produces clear correlation (see grey cells in Table 2).

In addition to the correlation values, the recording points and postures have other similarities to each other. Almost every part in Figure 6 has a notch or a peak at 100 milliseconds and a second notch/peak at 200 milliseconds. When observing the notch/peak at 200 milliseconds, we notice that it points upwards when the person is lying prone and downwards when they are lying supine. The behaviour of the 100-millisecond notch/peak is similar but inverted.

Respiration is most often visible when the recording is performed at abdominal height, while the person is lying prone or supine. This suggests that the respiratory signal originates from the movements of the diaphragm. Observing Figure 5, the respiratory activity seems to be similar to the respiratory activity in bioimpedance signals recorded with galvanic electrodes (Vuorela, 2008).

The near field imaging floor sensor under study can not match the cardiac monitoring distance of the ultra-high input impedance probes (Harland, 2001). The body of the person must be in direct contact with the insulating 3 mm floor covering. The bulk impedance between the sensor elements of the floor sensor system is approximately 650 Ω at 90 kHz. The human body is coupled parallel to these elements and is dominant compared to the bulk impedance only at very close ranges. This explains the low cardiac monitoring distance, which most probably causes the severe limitations in the postures. However, as far as we know, there is no implementation of probes with high input impedance incorporated in a system capable of tracking people. The fact that we can track a person and measure vital signs of a fallen person on an arbitrary point in the monitored space, makes this a novel method.

5 CONCLUSIONS

The floor sensor system under study was designed to track people, but also shows promise in vital sign

monitoring. Cardiac activity is clearly visible when a person is lying prone on the floor.

Waveform correlation between all the test subjects is clear when the recording posture is prone (at both measurement heights) or supine (at abdominal height). Respiration is most often visible when recording is performed at abdominal height while the person is lying prone or supine.

Combined with automatic fall detection, the vital sign monitoring capability would be most useful in many applications. These could include the care of the elderly and seclusion monitoring. The limitations in the favourable recording postures prevent the use of this vital sign monitoring method in crucial applications.

Our future work includes development of algorithms for automatic detection of the best vital sign recording point using the results obtained from this study. We also aim to publish our existing method for automatic fall detection.

ACKNOWLEDGEMENTS

This study was supported by the European Union and the Jenny and Antti Wihuri Foundation. The authors are also grateful to UPM Corporate Venturing for providing the necessary multi-layer thick film sensor laminates.

REFERENCES

- Rimminen, H., Linnavuo, M., and Sepponen, R., 2008. Human Tracking Using Near Field Imaging. In *Proceedings of the Second International Conference on Pervasive Health*, pp. 148-151. ICST.
- Prance, R. J., Debray, A., Clark, T. D., Prance, H., Nock, M., Harland, C. J., and Clippingdale, A. J., 2000. An ultra-low-noise electrical-potential probe for human-body scanning. In *Measurement Science and Technology, Volume 11, Issue 3*, pp. 291-297. Institute of Physics Publishing.
- Harland, C. J., Clark, T. D., and Prance, R. J., 2001. Electric potential probes —New Directions in The Remote Sensing of The Human Body. In *Measurement Science and Technology, Volume 13, Issue 2*, pp. 163-169. Institute of Physics Publishing.
- Smith, W. J., and LaCourse, J. R., 2004. Non-Contact Biopotential Recording from the Human Body Using a Low-Impedance Charge Amplifier. In *Proceedings of the 30th Annual International Conference on Bioengineering*, pp. 31-32. IEEE.
- Alametsä, J., Värri, A., Koivuluoma, M., and Barna, L., 2004. The Potential of EMFi Sensors in Heart Activity Monitoring. In *2nd OpenECG Workshop "Integration*

of the ECG into the EHR & Interoperability of ECG Device Systems", pp. 1.-3.

- Korjenevsky, A.V., 2004. Electric field tomography for contactless imaging of resistivity in biomedical applications. In *Physiological Measurement, Volume 25, Issue 1*. pp. 391-401. Institute of Physics Publishing.
- Tuykin, T.S., and Korjenevsky, A.V., 2007. Electric field tomography system with planar electrode array. In *Proceedings of the 13th International Conference on Electrical Bioimpedance and the 8th Conference on Electrical Impedance Tomography*, pp. 201-204. Springer Berlin Heidelberg.
- National Semiconductor Corporation, 1969. High Q Notch Filter. In *Linear Brief series, No. 5*. National Semiconductor.
- Patterson, R.P., 1989. Fundamentals of impedance cardiography. In *Engineering in Medicine and Biology Magazine, Volume 8, Issue 1*, pp. 35-38. IEEE.
- Vuorela, T., Vanhala, J., Seppä, V.-P., Hyttinen, J., 2008. Two portable long-term measurement devices for ECG and bioimpedance. In *Proceedings of the Second International Conference on Pervasive Health*, pp. 169-172. ICST.